

Product: EXCAVATOR

Model: 325B L EXCAVATOR 4DS

Configuration: 325B L & 325B LN Excavators 4DS00001-UP (MACHINE) POWERED BY 3116 Engine

Disassembly and Assembly

446 and 446B Backhoe Loaders, Lexion 450 Combine, 3114 and 3116 Engines, IT18F Integrated Toolcarrier, D6M Track-Type Tractor and 928F, 950F and 950G Wheel Loaders

Media Number -SEN3611-18

Publication Date -01/05/2009

Date Updated -27/05/2009

i01943334

Inlet and Exhaust Valves - Remove and Install

SMCS - 1105-010

Removal Procedure

Table 1

Required Tools			
Tool	Part Number	Part Description	Qty
A	5S-1330	Valve Spring Compressor	1

Start By:

- Remove the cylinder head assembly. Refer to Disassembly and Assembly, "Cylinder Head - Remove".

NOTICE

Keep all parts clean from contaminants.

Contaminants may cause rapid wear and shortened component life.

Note: For information on the reusability of the inlet valves, the exhaust valves and the springs, refer to Guideline For Reusable Parts And Salvage Operations, SEBF8002, "Valves, Valve Springs, Valve Rotators, and Locks", Guideline For Reusable Parts And Salvage Operations, SEBF8034, "Valve and Valve Spring Specifications", and Guideline For Reusable Parts And Salvage Operations, SEBF8162, "Specifications to Measure and Salvage Cylinder Head Assemblies and Related Components".

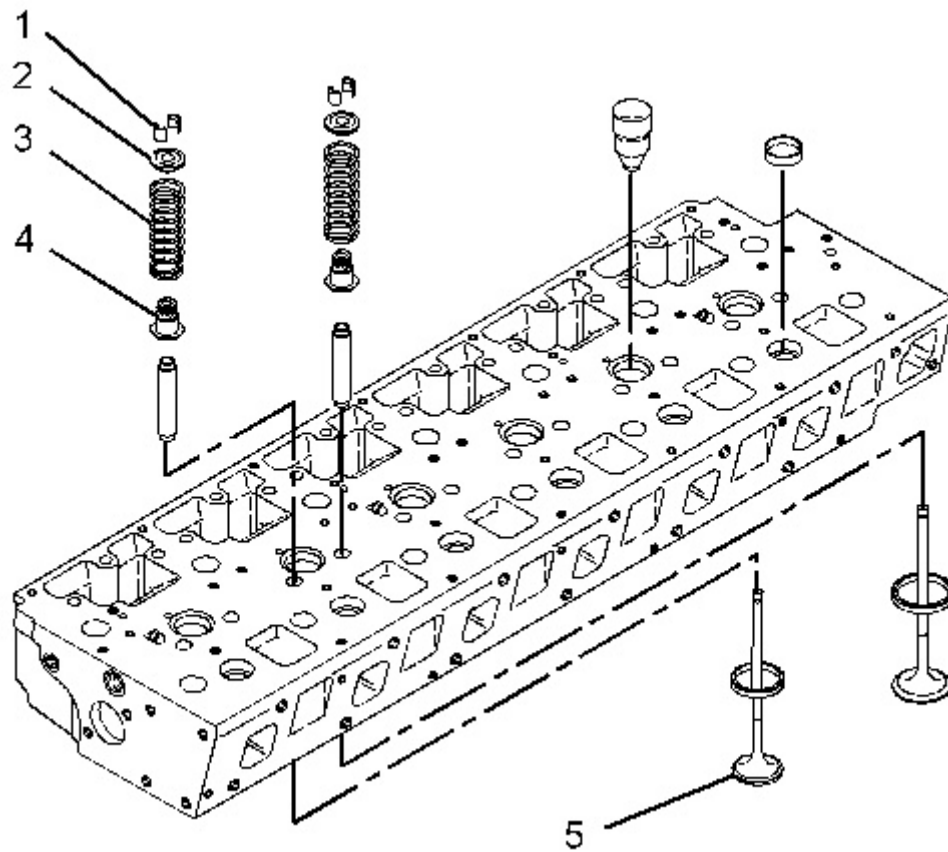

Illustration 1

g01011225

Note: The following components of the exhaust valves are different from the components of the inlet valves: spring retainer (2), valve spring (3) and valve (5).

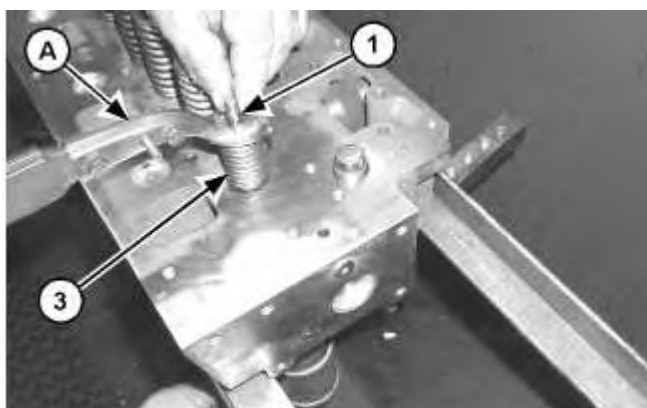

Illustration 2

g01011269

1. Use Tooling (A) to compress valve spring (3). Remove retainer lock (1).
2. Remove Tooling (A).
3. Remove spring retainer (2). Remove valve spring (3).

4. Remove valve seal (4) and valve (5).

5. Repeat Steps 1 through 4 in order to remove the remaining inlet valves and exhaust valves.

Installation Procedure

Table 2

Required Tools			
Tool	Part Number	Part Description	Qty
A	5S-1330	Valve Spring Compressor	1

NOTICE

Keep all parts clean from contaminants.

Contaminants may cause rapid wear and shortened component life.

Note: For information on the reusability of the inlet valves, the exhaust valves and the springs, refer to Guideline For Reusable Parts And Salvage Operations, SEBF8002, "Valves, Valve Springs, Valve Rotators, and Locks", Guideline For Reusable Parts And Salvage Operations, SEBF8034, "Valve and Valve Spring Specifications", and Guideline For Reusable Parts And Salvage Operations, SEBF8162, "Specifications to Measure and Salvage Cylinder Head Assemblies and Related Components".

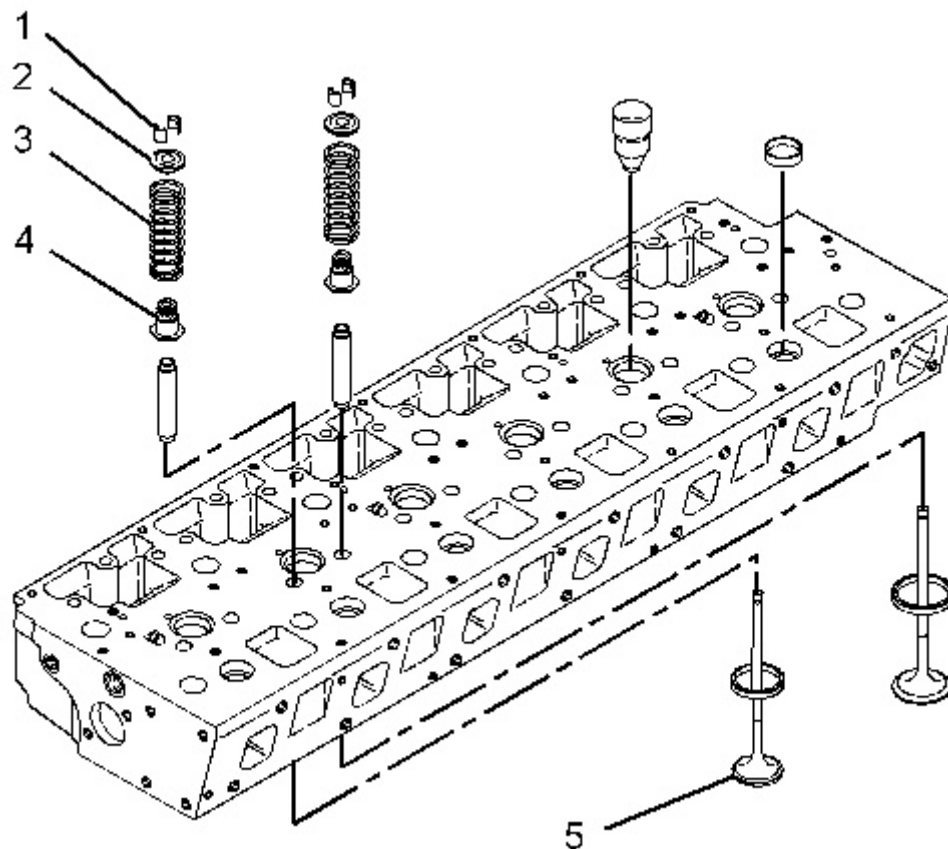

Illustration 3

g01011225

1. Lubricate valve (5) with clean engine oil. Install valve (5) in the cylinder head assembly. Install new valve seal (4) against the valve guide.
2. Place the following items on the valve stem: valve spring (3) and spring retainer (2).

! WARNING

The valve keepers can be thrown from the valve when the valve spring compressor is released. Ensure that the valve keepers are properly installed on the valve stem. To help prevent personal injury, keep away from the front of the valve keepers and valve springs during the installation of the valves.

Note: A small amount of grease can be used to hold retainer locks (1) in position during installation.

Thank you so much for reading.
Please click the “Buy Now!”
button below to download the
complete manual.



After you pay.

You can download the most
perfect and complete manual in
the world immediately.

Our support email:

ebooklibonline@outlook.com