

Product: EXCAVATOR

Model: 329D2 L EXCAVATOR KJB

Configuration: 329D2 L Excavators KJB00001-UP (MACHINE) POWERED BY C7.1 Engine

Disassembly and Assembly

C7.1 Engines

Media Number -UENR0633-19

Publication Date -01/07/2015

Date Updated -29/10/2018

i05292117

Crankshaft - Remove

SMCS - 1202-011

Removal Procedure

Table 1

Required Tools			
Tool	Part Number	Part Description	Qty
A	1U-8221	Lifting Sling	2

Start By:

- a. Remove the engine oil pump. Refer to Disassembly and Assembly, "Engine Oil Pump - Remove" for the correct procedure.
- b. Remove the front housing. Refer to Disassembly and Assembly, "Housing (Front) - Remove" for the correct procedure.
- c. Remove the crankshaft rear seal. Refer to Disassembly and Assembly, "Crankshaft Rear Seal - Remove" for the correct procedure.
- d. If necessary, remove the cylinder head. Refer to Disassembly and Assembly, "Cylinder Head - Remove" for the correct procedure.
- e. If necessary, remove the pistons and connecting rods. Refer to Disassembly and Assembly, "Pistons and Connecting Rods - Remove" for the correct procedure.

NOTICE

Keep all parts clean from contaminants.

Contaminants may cause rapid wear and shortened component life.

-
1. The engine should be mounted on a suitable stand and placed in the inverted position.
 2. If the cylinder head, the pistons and the connecting rods have not been removed already, remove the connecting rod bearings. Refer to Disassembly and Assembly, "Connecting Rod Bearings - Remove" for the correct procedure.
 3. Ensure that the main bearing caps are marked for the location and orientation.
-

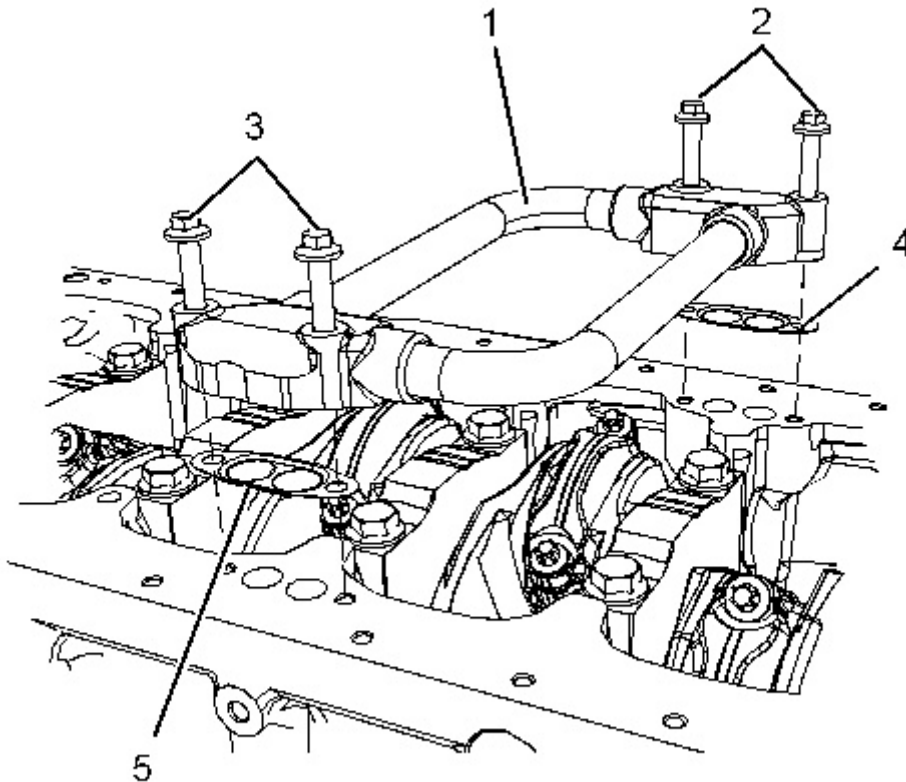

Illustration 1

g03412929

4. If necessary, follow Step 4.a through step 4.c to remove cross over tube assembly (1).
 - a. Remove bolts (2) and bolts (3) from cross over tube assembly (1).
 - b. Remove cross over tube assembly (1) from the cylinder block.
 - c. Remove gasket (4) and gasket (5).
-

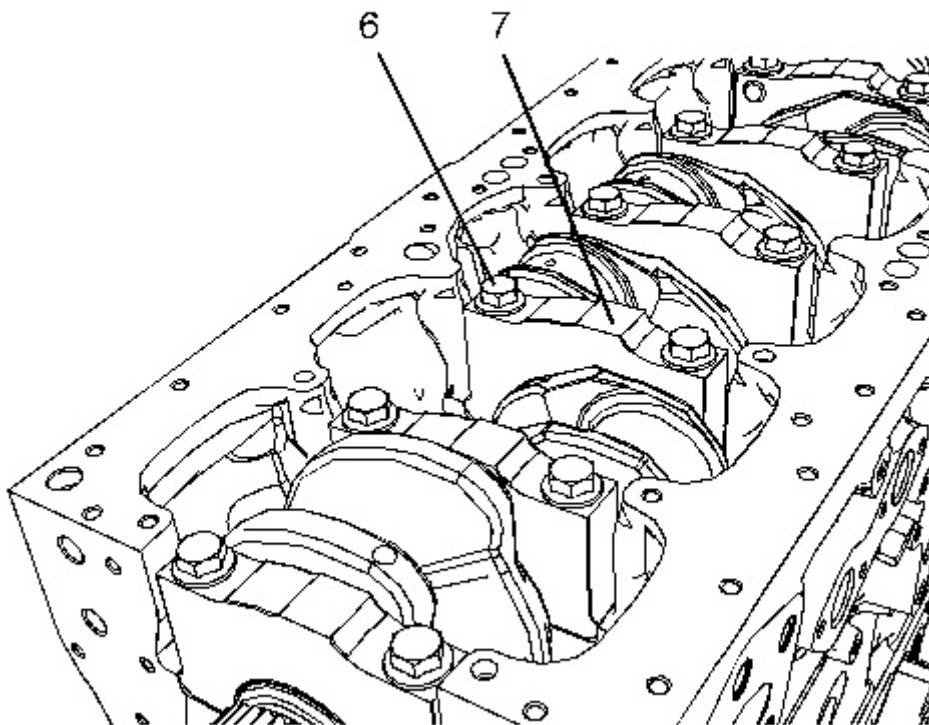

Illustration 2

g03412930

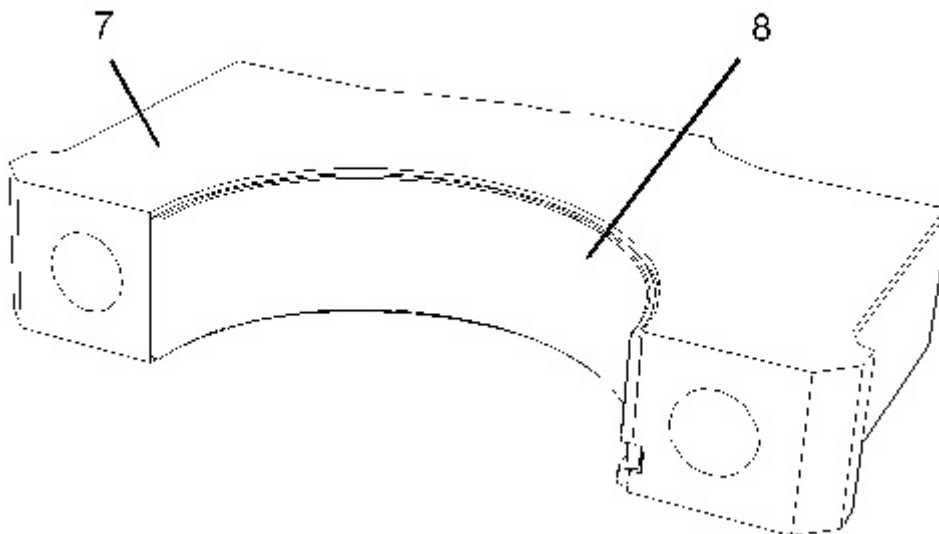

Illustration 3

g03412931

5. Remove bolts (6) and main bearing caps (7) from the cylinder block.
6. Remove lower main bearing shells (8) from main bearing caps (7). Keep the lower main bearing shells with the respective main bearing caps.

Thank you so much for reading.
Please click the “Buy Now!”
button below to download the
complete manual.



After you pay.

You can download the most
perfect and complete manual in
the world immediately.

Our support email:

ebooklibonline@outlook.com