

Product: EXCAVATOR

Model: 352F XE VG EXCAVATOR SD2

Configuration: 352F XE VG Excavator SD200001-UP (MACHINE) POWERED BY C13 Engine

## Disassembly and Assembly 349F XE and 352F XE Excavators Machine Systems

Media Number -UENR6800-01

Publication Date -01/09/2015

Date Updated -05/12/2017

i04243909

# Travel Motor - Disassemble

SMCS - 4351-015

## Disassembly Procedure

Table 1

Required Tools			
Tool	Part Number	Part Description	Qty
A	138-7574	Link Bracket	1
B	-	Bolt M4 x 0.7	1
C	6V-3010	Puller Gp	1
D	3E-3879	Eyebolt	1
E	9S-9152	Bearing Puller Gp	1

### Start By:

- a. Remove the travel motor.
    1. Drain the travel motor.
-

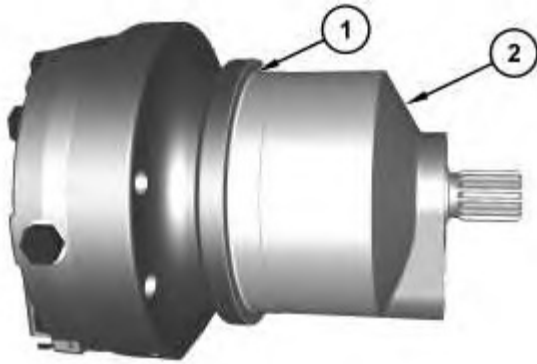

---

Illustration 1

g02419258

2. Remove O-ring seal (1) from motor housing (2).

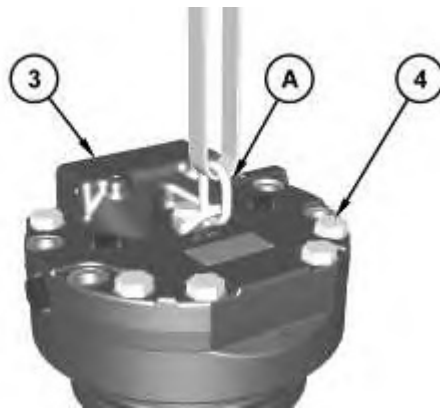

---

Illustration 2

g02419296



**Personal injury can result from being struck by parts propelled by a released spring force.**

**Make sure to wear all necessary protective equipment.**

**Follow the recommended procedure and use all recommended tooling to release the spring force.**

- 
3. Attach Tooling (A) onto head assembly (3). Remove bolts (4). Use Tooling (A) and a suitable lifting device to remove head (3). The weight of head assembly (3) is approximately 40 kg (90 lb).
-

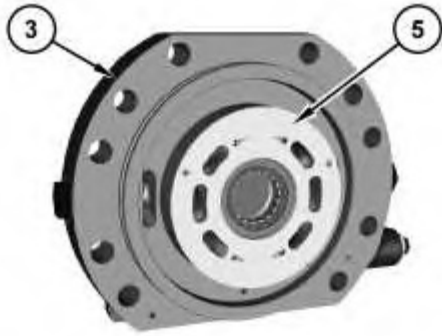

---

Illustration 3

g02419358

4. Remove plate (5) from head (3).

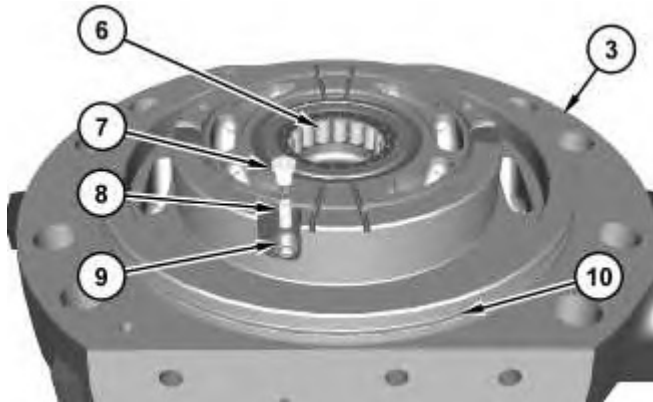

---

Illustration 4

g02419359

5. Remove bearing (6) from head assembly (3).
6. Remove orifice (7), spring (8), and ball (9).
7. Remove O-ring seal (10) from head assembly (3).



---

Illustration 5

g02419416

Thank you so much for reading.  
Please click the “Buy Now!”  
button below to download the  
complete manual.



After you pay.

You can download the most  
perfect and complete manual in  
the world immediately.

Our support email:

[ebooklibonline@outlook.com](mailto:ebooklibonline@outlook.com)