

Product: EXCAVATOR

Model: 352F EXCAVATOR MDR

Configuration: 352F XE Excavator MDR00001-UP (MACHINE) POWERED BY C13 Engine

Disassembly and Assembly C13 Engine for Caterpillar Built Machines

Media Number -UENR0131-06

Publication Date -01/05/2015

Date Updated -27/06/2018

i03533151

Valve Mechanism Cover Base - Remove and Install

SMCS - 1120-010

Removal Procedure

Start By:

- a. Remove the valve cover.

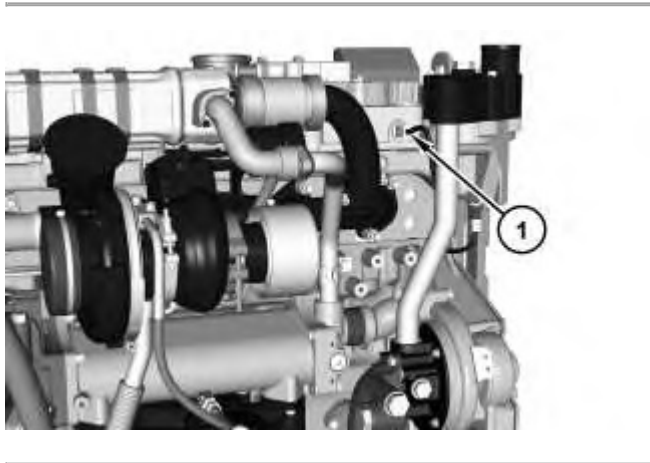

Illustration 1

g01861473

1. Disconnect harness assembly (1).
-

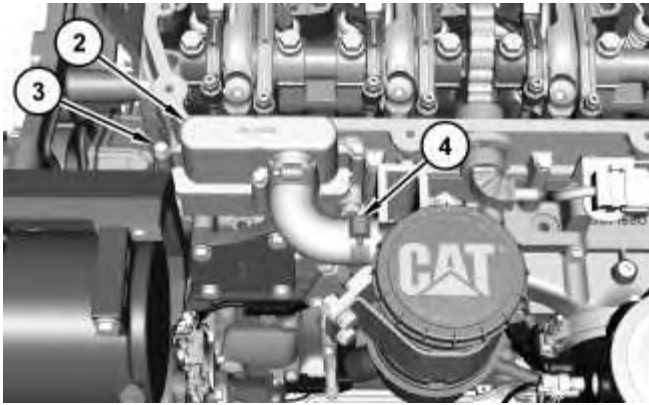

Illustration 2

g01861475

2. Loosen hose clamp (4). Remove bolts (3) and remove breather (2).

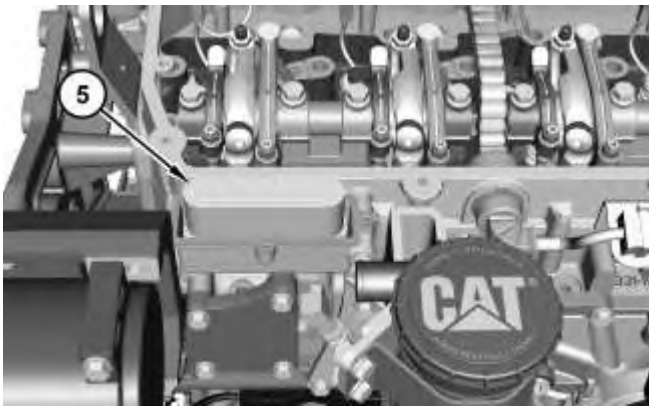

Illustration 3

g01861477

3. Remove element (5).

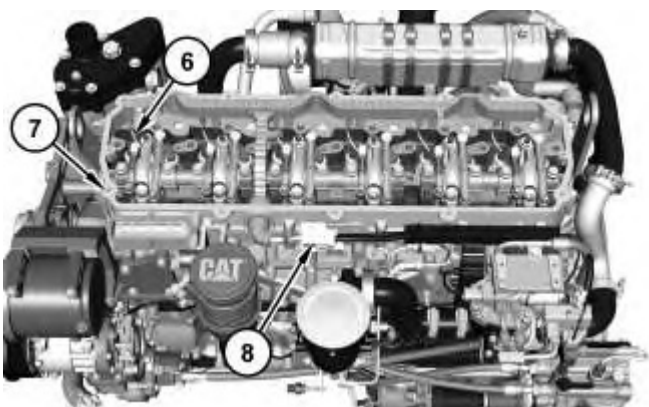

Illustration 4

g01861478

4. Disconnect harness assemblies (6) and (8). Remove valve cover base (7).



Illustration 5

g01861512

5. Remove seal (9) from valve cover base (7).

Installation Procedure

1. Install valve cover base (7) in reverse order of removal.
-

Thank you so much for reading.
Please click the “Buy Now!”
button below to download the
complete manual.



After you pay.

You can download the most
perfect and complete manual in
the world immediately.

Our support email:

ebooklibonline@outlook.com