

Illustration 12

g01283101

20. Remove port plate (29) from the travel motor.

Note: Note the location of springs (30) before removal.

21. Remove springs (30) from the travel motor.

22. Remove O-ring seals (31).



Illustration 13

g01283110

23. Place alignment marks on piston (32) and the housing. The dowel hole in piston (32) must be reinstalled to the original location.

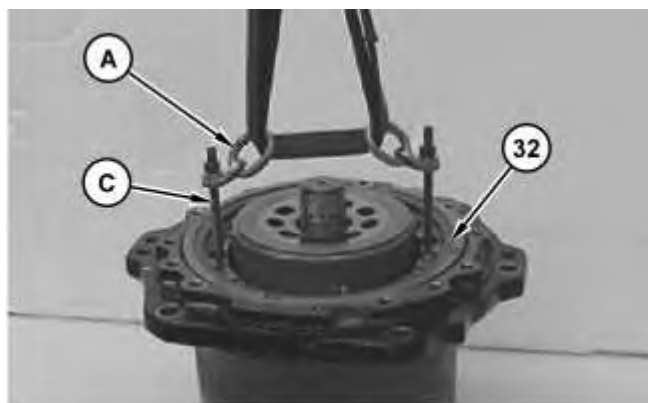

24. Install Tooling (C) to the threaded holes in piston (32). Install Tooling (A) and a suitable lifting device on Tooling (C), as shown. Remove piston (32) from the travel motor.

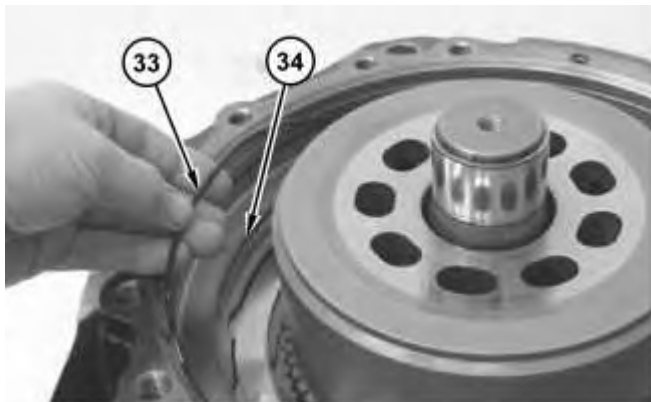

Illustration 15

25. Remove O-ring seals (33) and (34) from the travel motor.

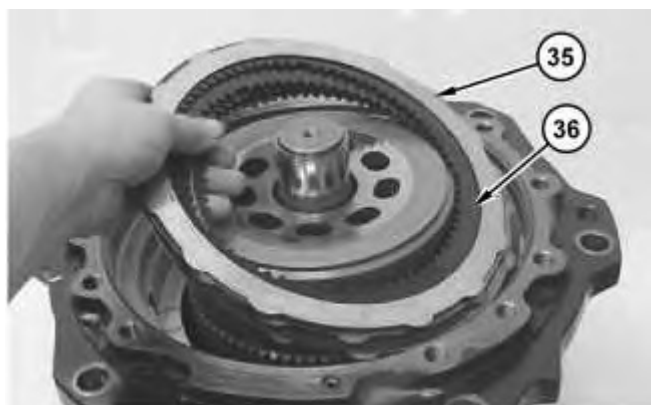

Illustration 16

26. Remove separator plates (35) and friction plates (36) from the travel motor.

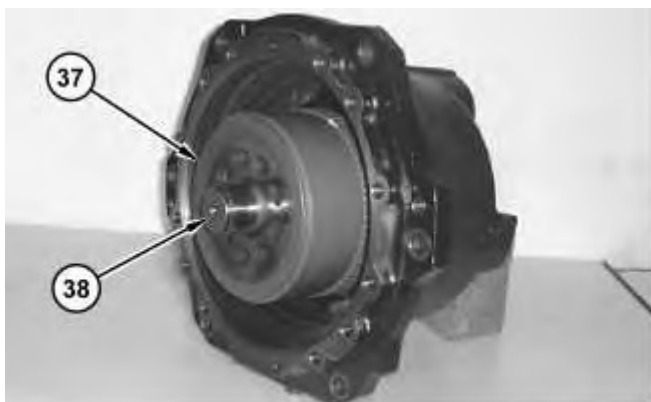

Illustration 17

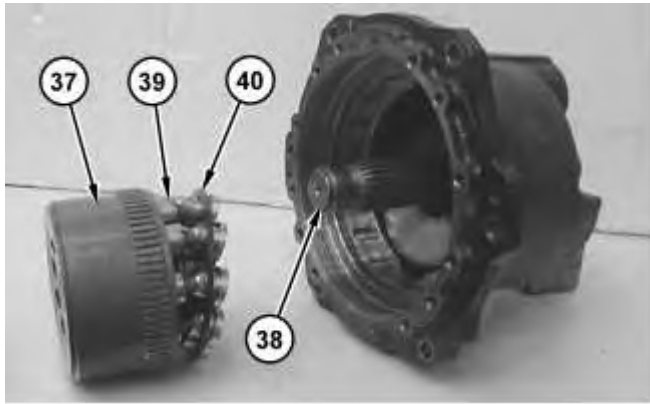

Illustration 18

g01283139

Note: Barrel assembly (37), piston assemblies (39), and retainer (40) must remain intact during removal.

27. Position the travel motor sideways. Carefully remove barrel assembly (37) from shaft (38).



Illustration 19

g01283155

28. Place identification marks on piston assemblies (39), retainer (40), and barrel assembly (37). These components must be reinstalled in the original location.
29. Remove retainer (40) and piston assemblies (39) from barrel assembly (37).

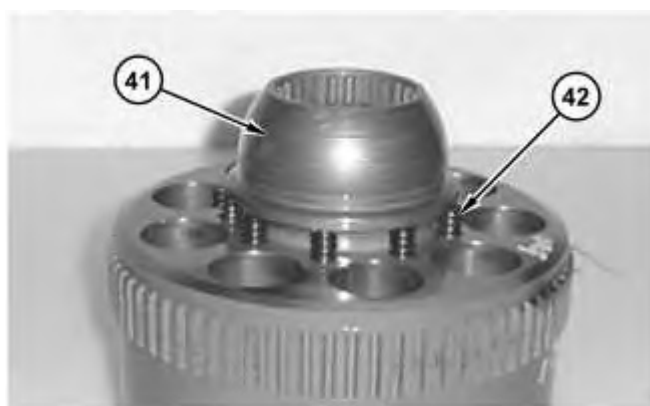

Thank you so much for reading.
Please click the “Buy Now!”
button below to download the
complete manual.



After you pay.

You can download the most
perfect and complete manual in
the world immediately.

Our support email:

ebooklibonline@outlook.com