

C13 ENS M33 C13 ENT M50

TECHNICAL AND REPAIR MANUAL

JUNE 2007 EDITION

TECHNOLOGICAL EXCELLENCE

**IVECO
MOTORS**



SECTION CONTENTS

| Section | Page |
|--|------|
| 1. OVERVIEW | 5 |
| 2. TECHNICAL DATA | 35 |
| 3. ELECTRICAL EQUIPMENT | 41 |
| 4. DIAGNOSTICS | 67 |
| 5. MAINTENANCE | 89 |
| 6. SERVICING OPERATIONS ON INSTALLED ENGINE | 95 |
| 7. TOOLS | 113 |
| 8. OVERHAUL | 125 |
| 9. C13 ENS M33 ENGINE | 197 |
| 10. SAFETY SYSTEM FOR HOMOLOGATED INSTALLATIONS | 209 |
| 11. SAFETY REGULATIONS | 235 |

Indications for consultation

The several engine versions are usually explained with common images and descriptions. In cases of considerable differences, they are explained separately.

The specific characteristics of the C13 ENS M33 engine electric system are described in Section 9.

Sections 1-2-3 are intended for sales personnel, to provide them with an exact knowledge of the product's characteristics and enable them to accurately meet the Customer's requirements.

The remaining sections are intended for the personnel that has the task of performing both ordinary and extraordinary maintenance; by referring carefully to the chapter devoted to diagnosis, they too will be able to provide an effective service of technical assistance.

SECTION 1

OVERVIEW

| | Page |
|--|------|
| IDENTIFICATION DATA | 7 |
| Identification Tag | 7 |
| COMMERCIAL CODE | 8 |
| PRODUCT MODEL NUMBER | 9 |
| ENGINE PARTS AND COMPONENTS | 10 |
| ENGINE ARCHITECTURE | 12 |
| COMBUSTION AIR INTAKE AND EXHAUST SYSTEM | 14 |
| Air/sea water heat exchanger | 15 |
| Combustion air pre-heating | 15 |
| Intake and exhaust assembly | 15 |
| COOLING FRESH WATER CLOSED LOOP | 16 |
| Tube bundle water/water heat exchanger | 17 |
| Bypass junction for thermostatic valve | 17 |
| SEA WATER OPEN COOLING LOOP | 18 |
| Sea water pump | 19 |
| ENGINE OIL - LUBRICATION LOOP | 20 |
| Gear pump | 21 |
| Oil vapor filter | 21 |
| Pre-lubrication system (on request) | 21 |
| Commutable filters (on request) | 21 |
| FUEL LINES | 22 |
| Hydraulic schematic diagram | 23 |
| INJECTION SYSTEM - EDC | 24 |
| EUI electrically controlled pumping injector | 25 |
| Electrical and electronic components | 28 |
| System functions | 30 |
| Reference signals | 32 |

IDENTIFICATION DATA

Figure 1

Identification Tag

| | | | |
|--|----------------------|----------------------|----------------------|
| IVECO S. p. A. | | | |
| Viale dell'Industria, 15/17 - 20010 Pregnana Mil.se MI - ITALY | | | |
| ENGINE TYPE | <input type="text"/> | | |
| ENGINE FAMILY | <input type="text"/> | ENGINE DWG | <input type="text"/> |
| POWER (KW) AND SPEED (RPM) | <input type="text"/> | POWER SET CODE | <input type="text"/> |
| ENGINE S/N | <input type="text"/> | YEAR OF BUILD | <input type="text"/> |
| HOMOLOGATION | <input type="text"/> | N° | <input type="text"/> |
| COMMERC. TYPE / VERSION | <input type="text"/> | <input type="text"/> | <input type="text"/> |

04_002_N

Figure 2

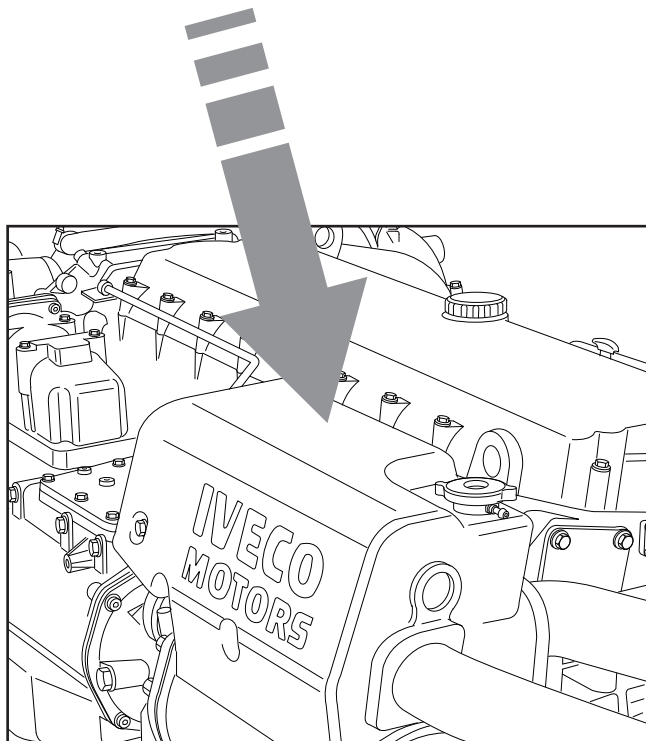

05_001_C

The engine identification data are stenciled on a tag positioned over the engine coolant tank.

COMMERCIAL CODE

The purpose of the commercial code is to make it easier to understand the characteristics of the product, categorizing the engines according to their family, origins and intended application. The commercial code, therefore, cannot be used for technical purposes and to identify the engine's components, this is the purpose of the "ENGINE S/N".

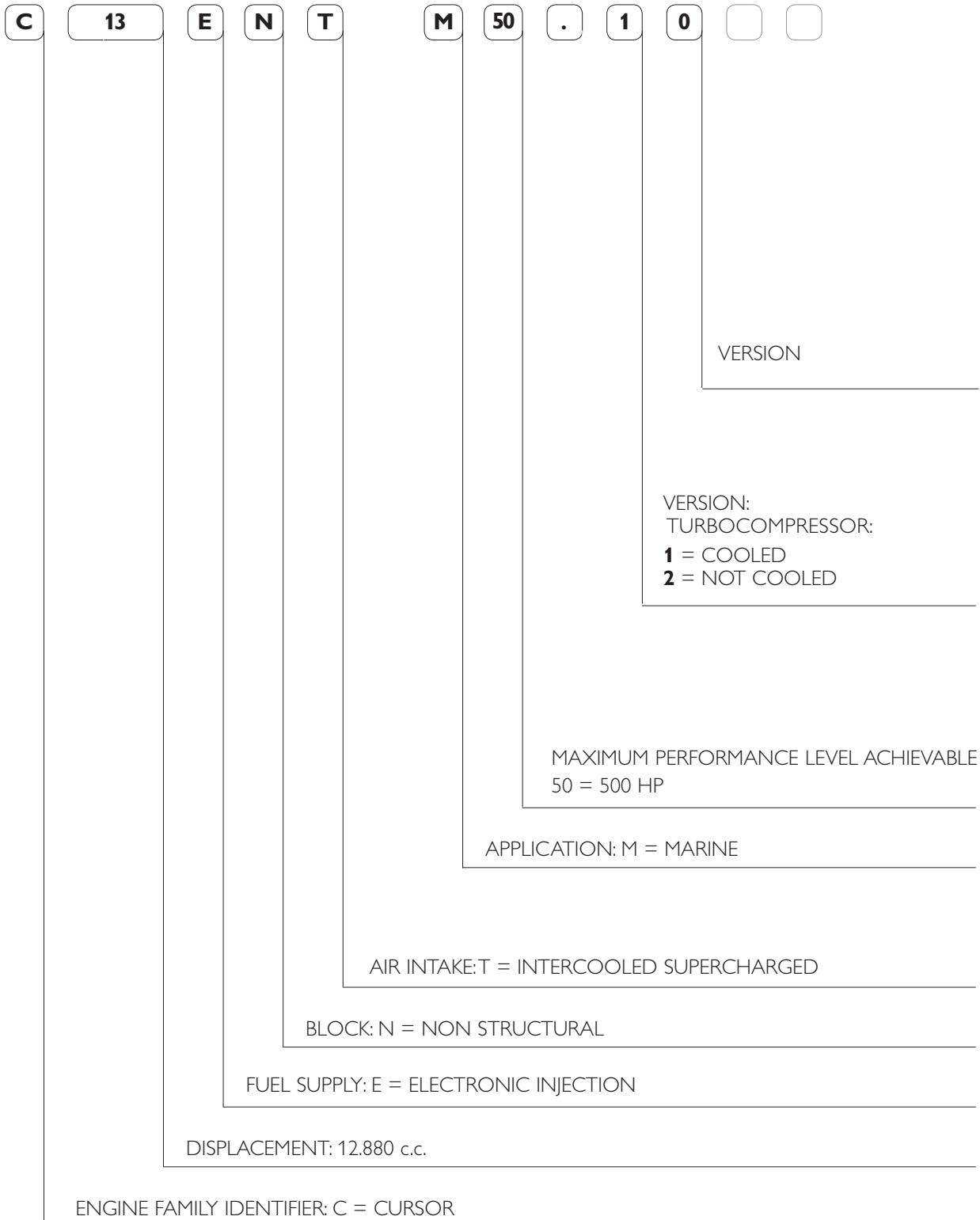

PRODUCT MODEL NUMBER

The model number is assigned by the manufacturer; it is used to identify the main characteristics of the engine, and to characterize its application and power output level. It is stamped on the side of the crank-case.

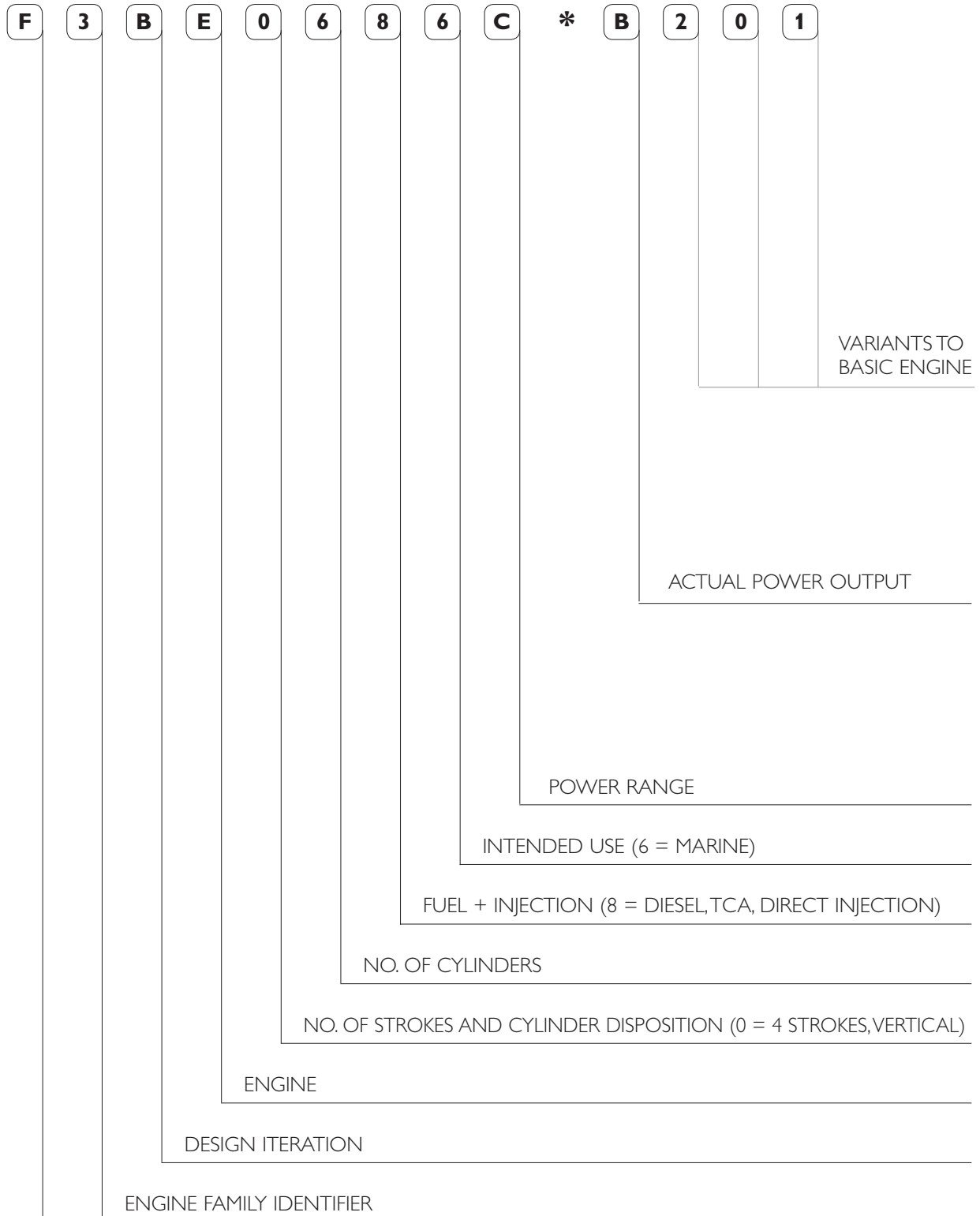

ENGINE PARTS AND COMPONENTS

Figure 3

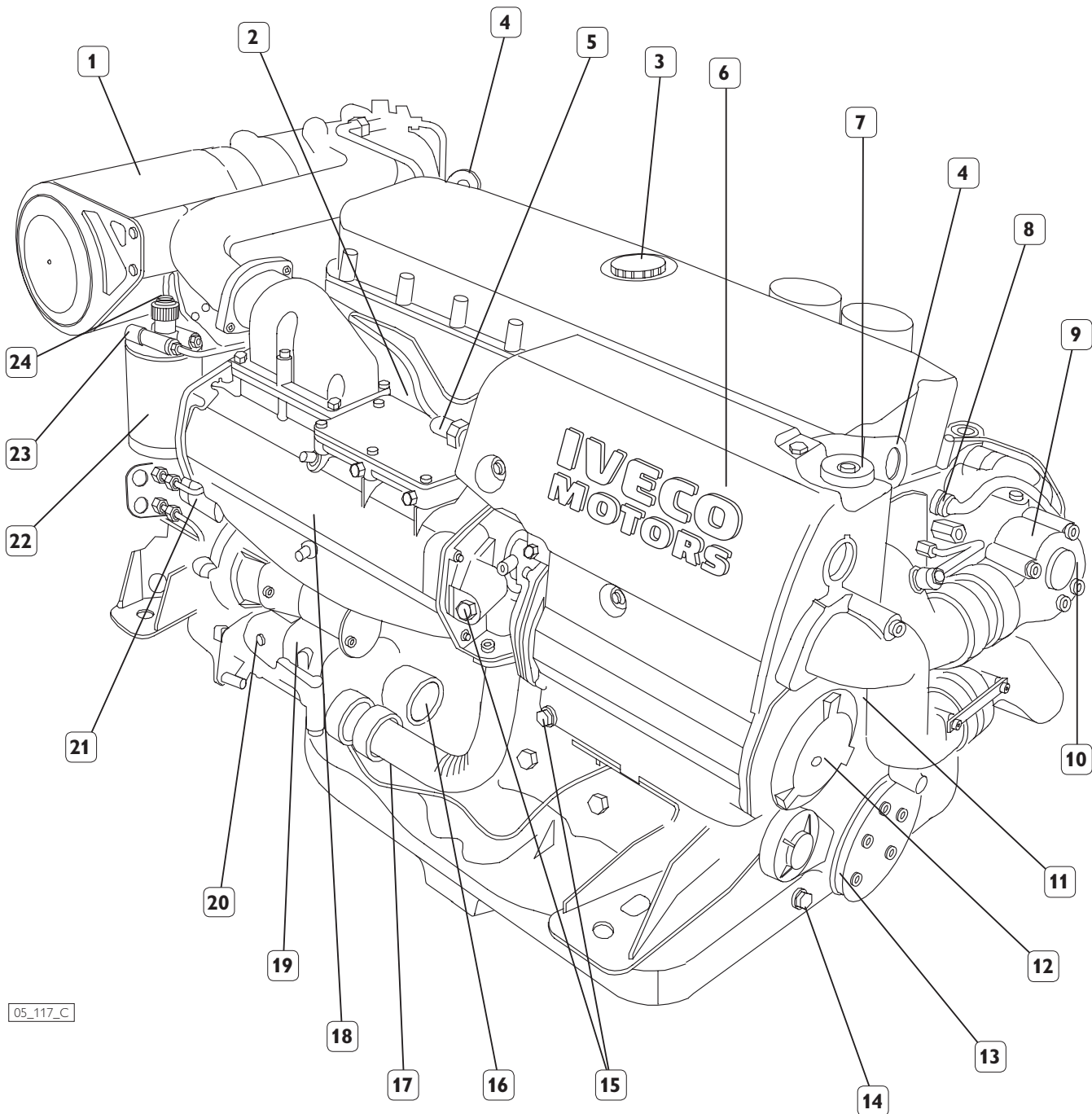

05_117_C

1. Intake air filter - 2. Location of intake air pressure and temperature sensor - 3. Lubricating oil refill cap - 4. Lifting padeyes - 5. Coolant level sensor - 6. Engine coolant tank - 7. Coolant refill cap - 8. Injector solenoid valve connector - 9. Location of thermostatic valve - 10. Cap for engine coolant outlet to sanitary water heating system - 11. Alternator location - 12. Coolant-sea water tube bundle heat exchanger - 13. Auxiliary pulley - 14. Oil drain sump plug - 15. Sacrificial anodes - 16. Sea water intake - 17. Sea water drain plug - 18. Air-sea water heat exchanger (not present on the C13 ENS M33 engine) - 19. Sea water pump - 20. Electrical starter motor - 21. Fuel transfer pump - 22. Fuel filter - 23. Filter clogging sensor - 24. Fuel temperature sensor.

Figure 4

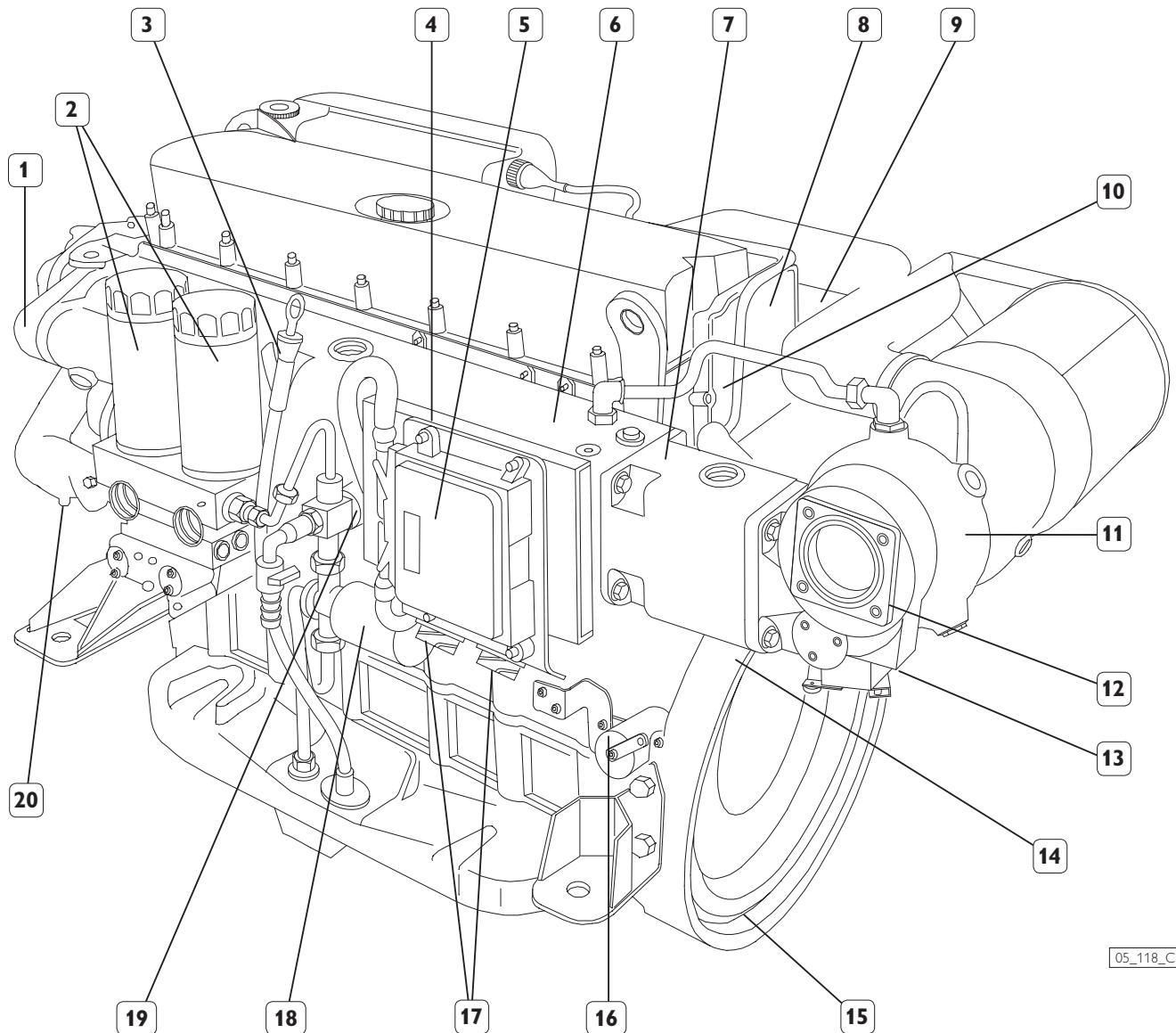

05_118_C

1. Coolant feed to exhaust manifold - 2. Lubricating oil filters - 3. Lubricating oil dipstick - 4. Insulated support - 5. Electronic Central Unit - 6. Cooled exhaust manifold - 7. Turbocharger inlet pipe-fitting - 8. Timing mechanism and oil vapor filter cover - 9. Location of timing phase sensor - 10. Oil filter clogging indicator - 11. Cooled turbo-charger - 12. Exhaust gas outlet flange - 13. Waste-gate actuator - 14. Phase and engine shaft rotation sensor location - 15. Timing phase inspection port - 16. Throttle position sensor potentiometer - 17. Electrical equipment wiring connectors - 18. Oil fill-in fill-out/pre-lubrication electrical pump (optional) - 19. Oil fill-in fill-out/pre-lubrication electrical pump solenoid valve (optional) - 20. Cap for engine coolant discharge and recyrculation from sanitary water heating system.

ENGINE ARCHITECTURE

Figure 5

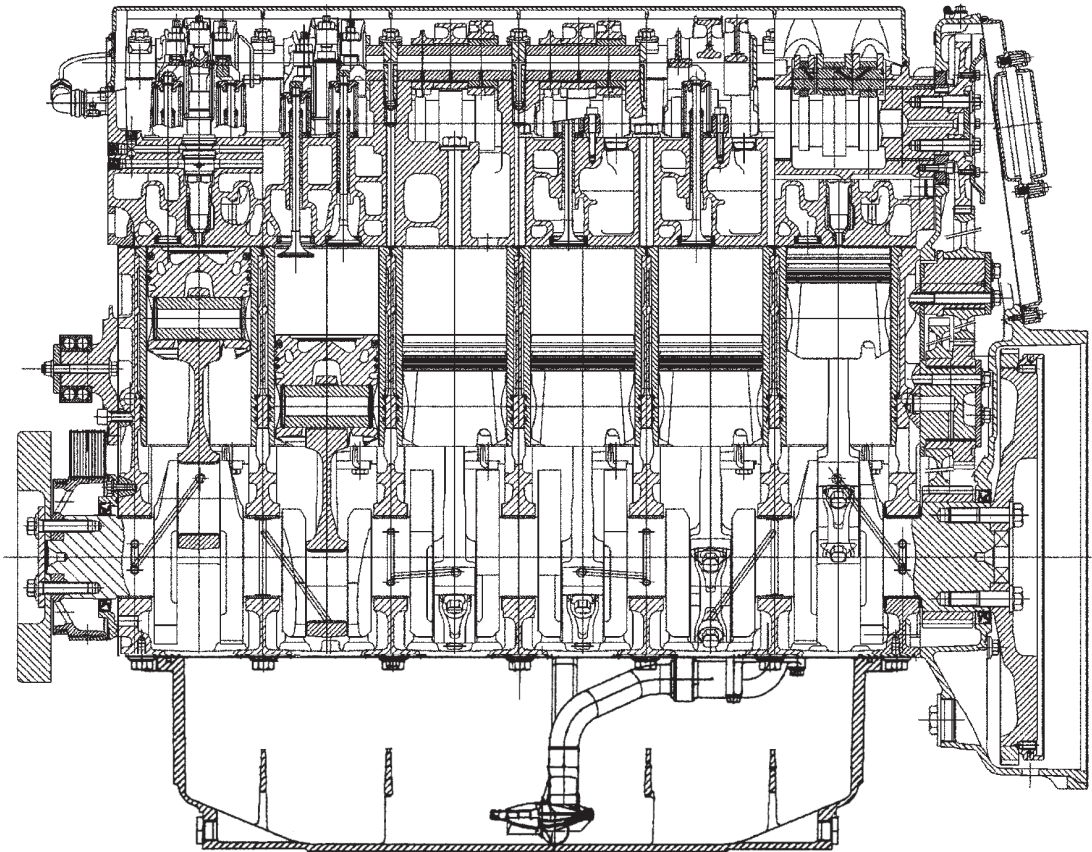

05_076_C

With the CURSOR series engines, IVECO MOTORS-FPT has reached unequalled standards in power delivery for industrial, marine, and automotive uses; CURSOR engines are the result of a continuous research process aimed at product improvement, and they inherit no elements of previous propulsion units. They adopt the most rational and effective solutions to achieve, with smaller displacement engines, power outputs that are typical of larger, heavier engines.

The architecture of these engines is characterized by six cylinders in line, four valves per cylinder and roller rocker arms with overhead cam shaft and "bonded" block.

Electronic control extended to all functions ensures reliable and durable operation, offering important benefits in terms of performance and usage.

IVECO MOTORS-FPT's contribution to environmental protection is amply demonstrated by the CURSOR engines' environmental performance: fumes and noise are well below current regulatory requirements and compliance with future limits was the target of the whole design effort.

The 24 valve cylinder head with its camshaft with seven supports, incorporates the intake manifold and the conduits for the cooling and lubrication fluids, as well as for fuel supply.

The overhead camshaft with roller rocker arms directly activates both the valves and the EUI (Electrical Unit Injector).

Figure 6

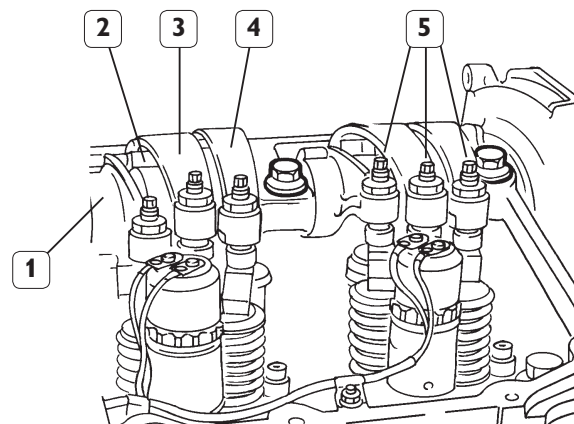

80877

1. Rocker arm shaft -
2. Intake valve rocker arm -
3. Pump injector rocker arm -
4. Exhaust valve rocker arm -
5. Calibration screw.

Figure 7

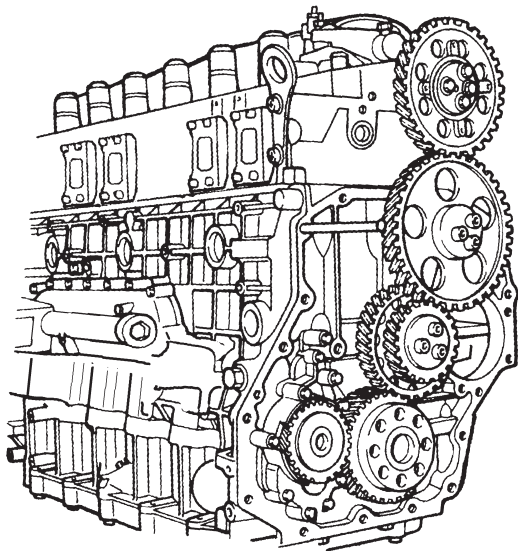

80824

Timing control is to the rear to reduce torsional effects and it is built with helical tooth gears to contain noise.

Figure 8

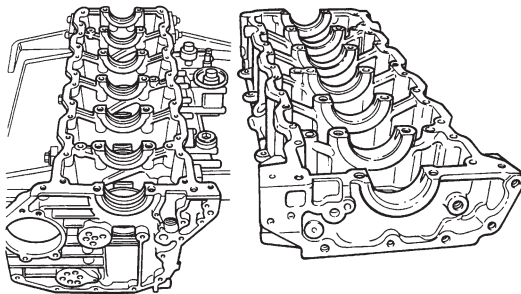

80825

Block and sub-block constitute a rigid assembly to reduce vibration and noise and secure the drive shaft with seven shaft supports. Aluminum pistons provide effective heat dissipation.

Pump injectors are mounted at the center of the combustion chamber and provide the highest possible thermodynamic efficiency thanks to an injection that is able to reach pressures that exceed 1600 bar. Electrically driven by the electronic control, they deliver fuel at a time that minimizes fuel consumption and contains gas emissions, while maximizing torque and power output.

The EDC, Electronic-Diesel-Control system, constantly monitors environmental and engine operating conditions, providing an optimized injection control to maximize performance at all times. Even when operating in critical conditions, control is optimized. This permits navigation and operation to continue in complete safety.

The electronic unit's control over the entire engine's efficiency provides information about the engine's global performance and other; specific, information for each cylinder, thereby making servicing operations easy; associated with the testing of the working condition of the injection system's electrical and electronic components, it stores information about the most significant events that occur during the engine's operation and allows maintenance personnel to anticipate the onset of faults and resolve them.

COMBUSTION AIR INTAKE AND EXHAUST SYSTEM

Figure 9

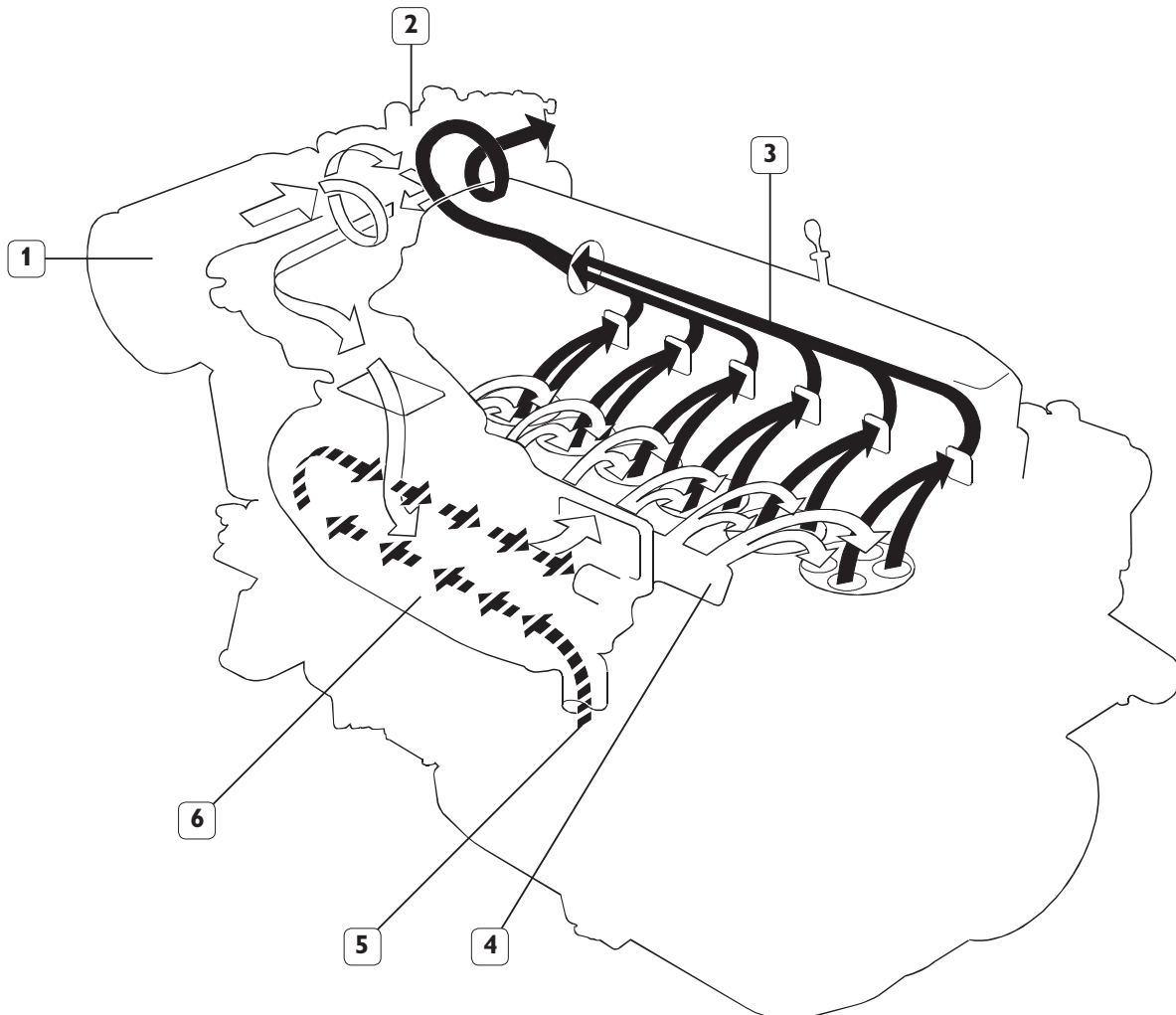

80826

Intake
 Exhaust
 Sea water

1. Air filter - 2. Turbocompressor - 3. Exhaust gas manifold - 4. Intake manifold incorporated in cylinder head - 5. Sea water inlet from pump - 6. Air/sea water heat exchanger (not present on the C13 ENS M33 engine).

Description and Operation

Air, drawn in and compressed by the turbocompressor, flows through the heat exchanger together with sea water. The latter, by reducing temperature, allows an increase in the engine's volumetric efficiency.

The air density at the inlet of the intake manifold is measured by two sensors, for pressure and temperature, allowing the ECU of the EDC system to calculate fuel dosage relative to the actual quantity of air available for combustion.

Lubricating oil vapors (blow-by) not condensed in the separator, are sent to the engine intake by a gauged hole downstream of the air filter.

Exhaust gas expelled by the engine flows through the cooled exhaust manifold to reach the turbocompressor rotor wherein, depending on the supercharging pressure reached, it may be switched by waste gate to exhaust to limit the thrust exerted on the turbocompressor rotor and contain the pressure generated by the compressor within the maximum rated value.

Exhaust manifold and turbocompressor body are cooled by the fresh water loop. Exhaust gases flow into the exhaust terminal and, when provided, they are mixed with the sea water it carries for overboard discharge.

Air/sea water heat exchanger

Figure 10

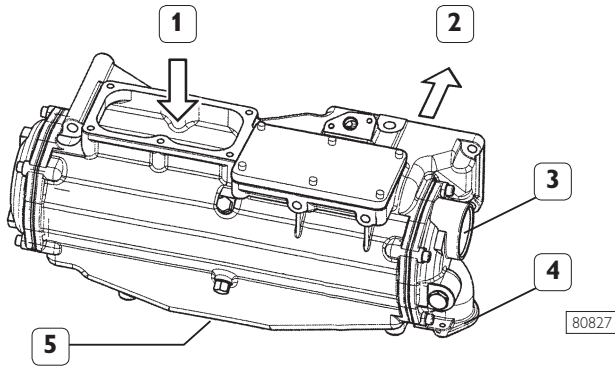

- 1. Air inlet from the turbocompressor - 2. Outlet for air cooled by the sea water and destined to the intake manifold -
- 3. Sea water outlet - 4. Sea water inlet -
- 5. Condensed water outlet.

**Combustion air pre-heating
(not available at the moment)**

Figure 12

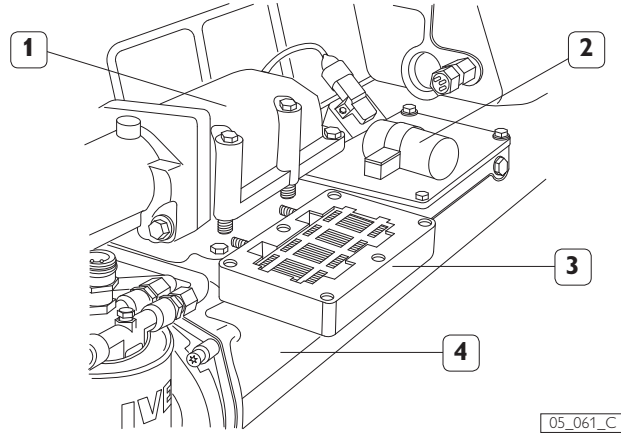

- 1. Pre-heating junction - 2. Power relay - 3. Electrical heating element - 4. Air/water heat exchanger.

Engine start is guaranteed down to -15 °C without the aid of any pre-heating system. If the engine needs to be used at lower temperatures, there are provisions (on request) for the installation of an electrical heating element driven by the injection system ECU.

When the ECU, through its sensors, recognizes the presence of a temperature below the prescribed threshold, it will energize the power relay that controls the electrical supply to the grid heater.

The heating element will be located at the inlet of the air/water heat exchanger (after-cooler) after replacing the overlying junction.

Intake and exhaust assembly

Figure 11

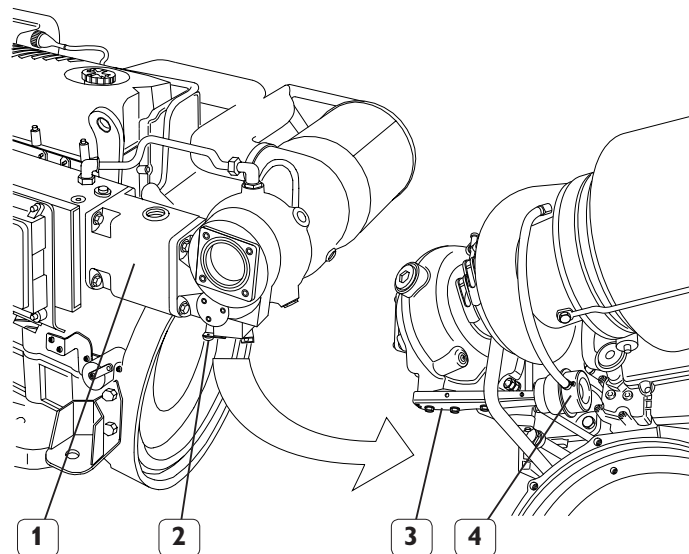

- 1. Turbocompressor supply feeder-line - 2. Waste gate valve command rod - 3. Command rod guard -
- 4. Waste gate valve pneumatic actuator.

COOLING FRESH WATER CLOSED LOOP

Figure 13

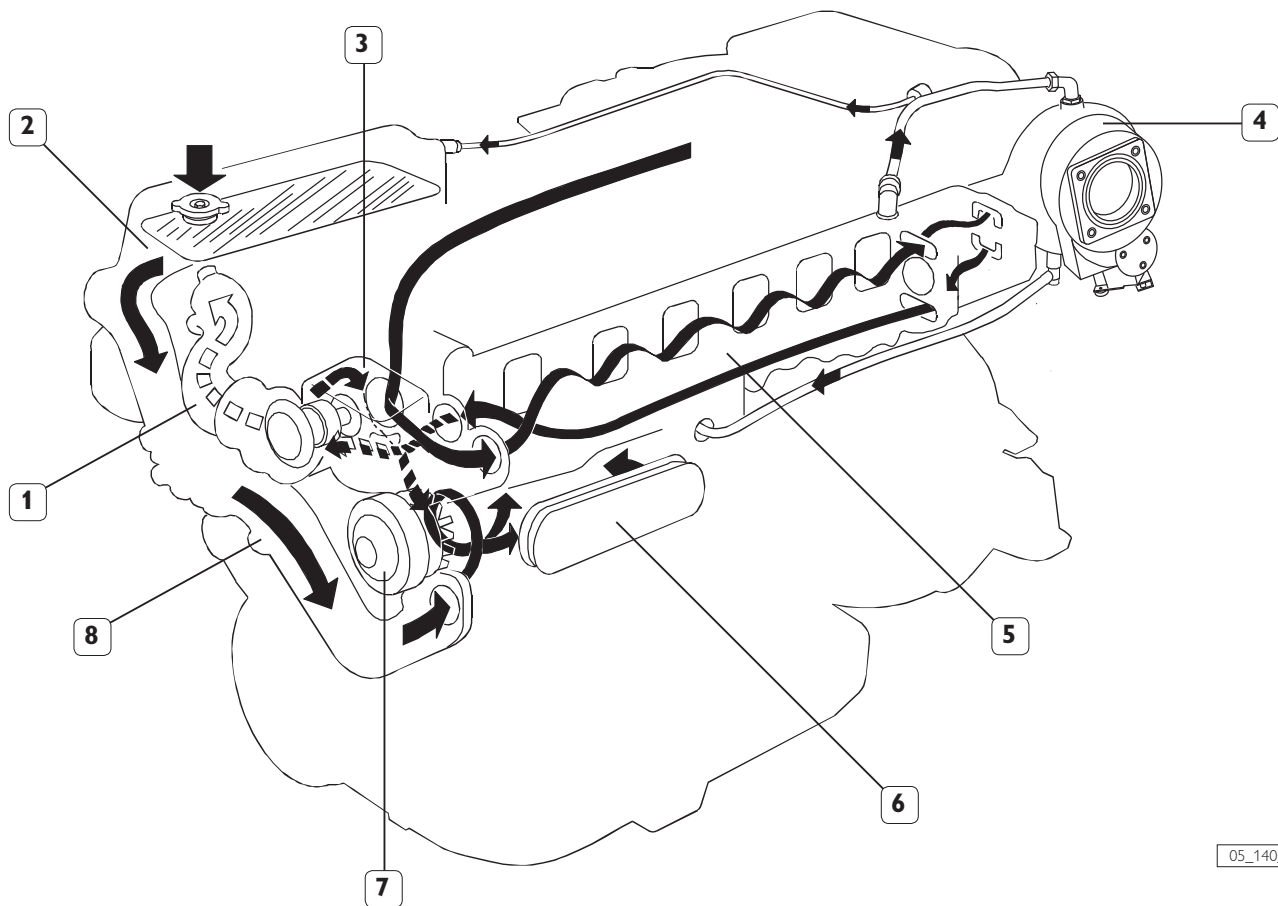

05_140_C

□□□□ High temperature liquid

■ Low temperature liquid

1. Thermostatic valve/coolant tank junction pipe - 2. Coolant tank incorporated in sea water heat exchanger - 3. Bypass junction for thermostatic valve - 4. Turbocompressor - 5. Cooled exhaust manifold - 6. Engine oil/coolant heat exchanger - 7. Coolant pump - 8. Heat exchanger junction pipe.

Description and operation

The centrifuge pump, rotated by the drive shaft with a poly-V belt, draws in the coolant coming from the fresh water/sea water heat exchanger or from the exhaust manifold cooling loop and sends it into the block, where it comes in contact with the lubricating oil heat exchanger. It then touches the heat exchange areas of the cylinders and subsequently those of the engine head, from which it exits flowing through the junction fitting that contains the temperature sensors for the instrument panel and the injection system. This junction has the purpose of bypassing the coolant from the engine head to the exhaust manifold and from the exhaust manifold to the thermostat - which routes it according to the temperature either to the water/water heat exchanger or to the recirculation pump.

From the bypass fitting the liquid is then injected into the heat exchange chamber of the exhaust manifold - through which it flows going to touch the body of the waste gate, of a portion the exhaust and of the turbo compressor. When it returns into the bypass junction it comes in contact with the wax actuator of the thermostatic valve. This will throttle flows according to temperature.

Part of the liquid will enter the tank and flow through the tube bundle heat exchanger, releasing heat to sea water, while the rest will go directly to the pump, to be recirculated.

Tube bundle water/water heat exchanger

Figure 13

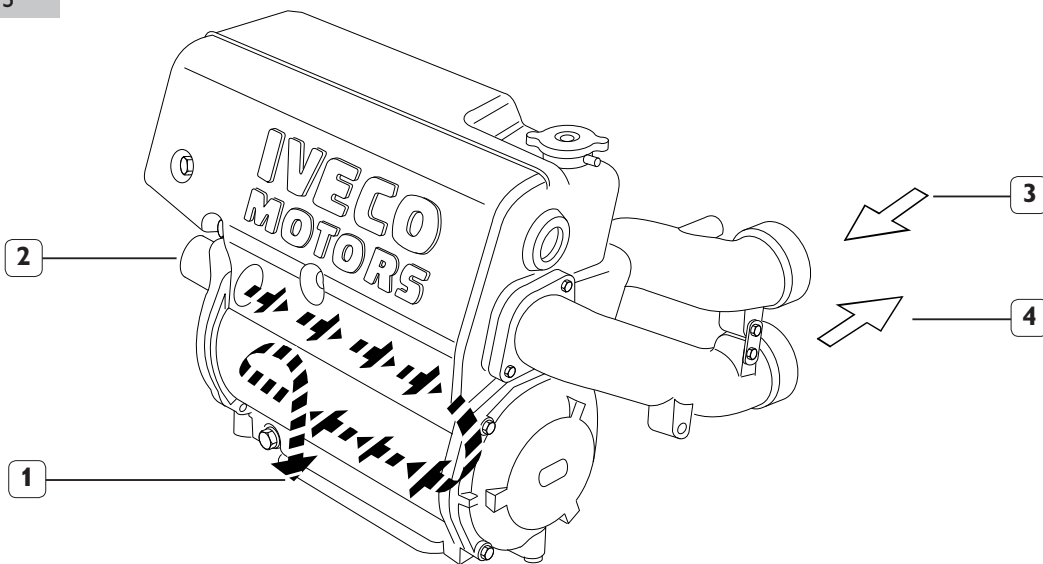

05_077_C

High temperature liquid
 Sea water

- 1. Sea water outlet to overboard discharge - 2. Sea water inlet from after cooler - 3. Coolant inlet from thermostatic valve - 4. Coolant outlet to pump.

Bypass junction for thermostatic valve

Figure 15

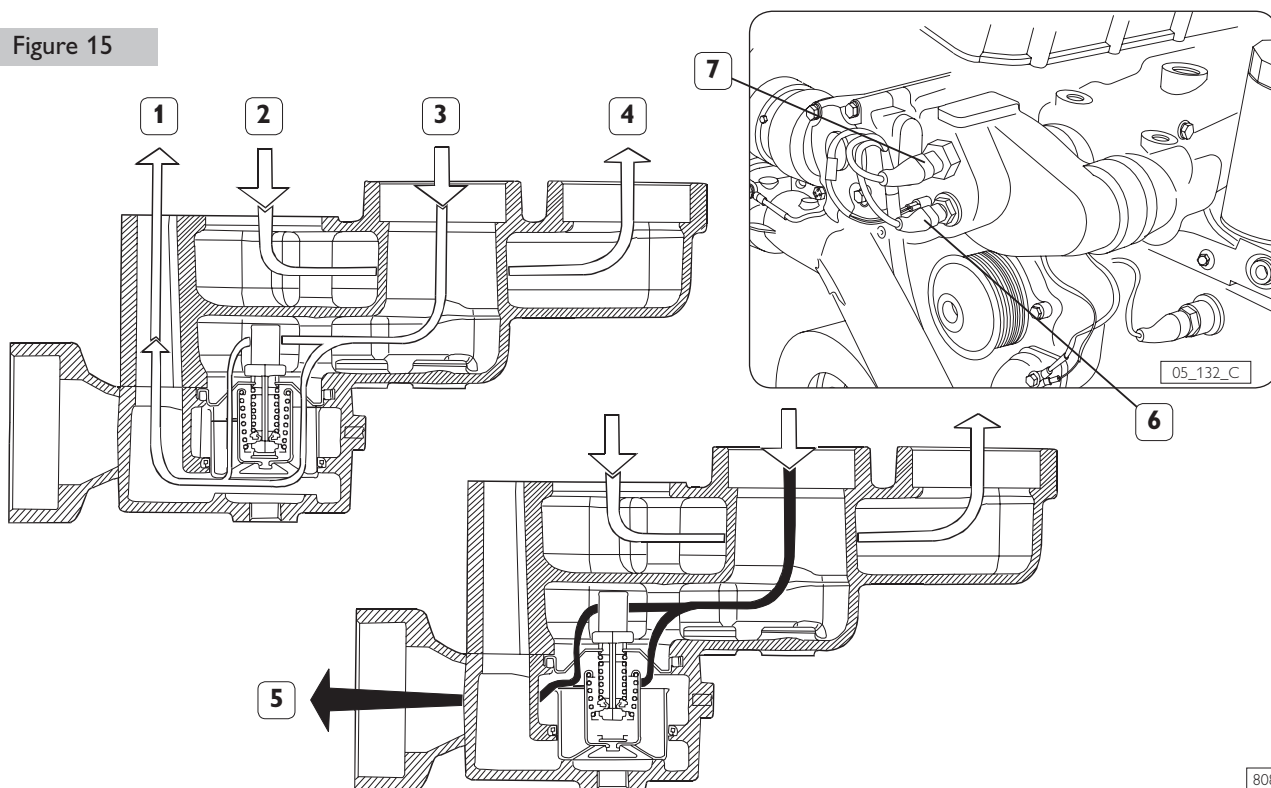

05_132_C

80832

- 1. Bypass flow to engine - 2. Outflow from engine - 3. Outflow from exhaust manifold - 4. Inflow to exhaust manifold - 5. Flow to sea water heat exchanger - 6. EDC temperature sensor - 7. Temperature sensor for the control panel and indicators.

SEA WATER OPEN COOLING LOOP

Figure 16

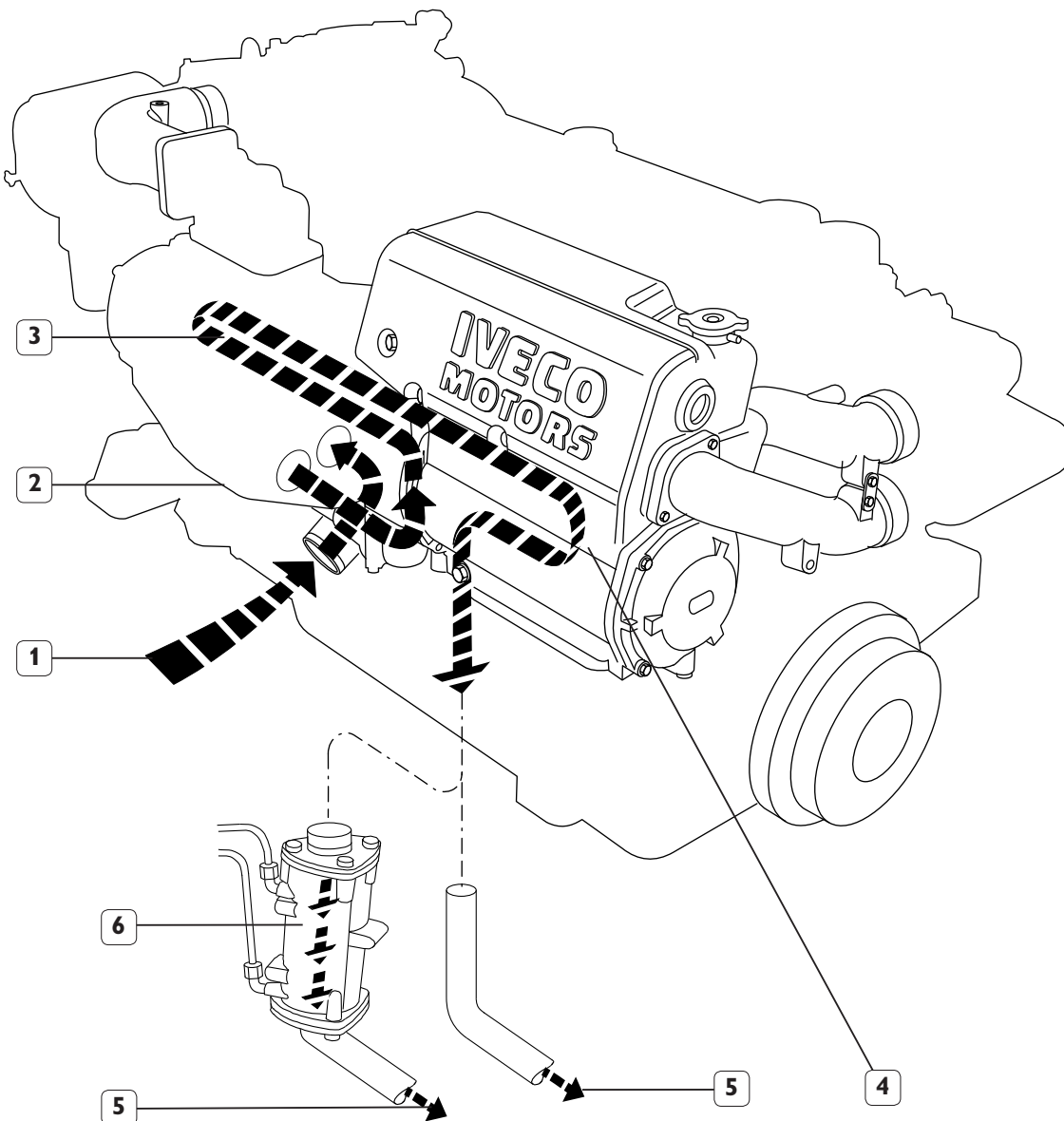

05_080_C

■■■■ Sea water

1. Sea water suction - 2. Sea water pump - 3. Supercharger air heat exchanger (not present on the C13 ENS M33 engine) -
4. Coolant (fresh water) heat exchanger - 5. Sea water outlet from heat exchangers for overboard discharge -
6. Heat exchanger for gearbox oil (on request).

Description and operation

Sea water, drawn from under the keel and necessarily filtered, is drawn by the pump and sent to the supercharger air heat exchanger and from there to the water/water heat exchanger of the closed cooling loop; only after this will it flow through the heat exchanger for the gearbox oil, if one is provided.

The configuration of the discharge lines depends on the choice of a dry "chimney" exhaust, or a mixed one. The outlet pipe will carry the water directly to the overboard discharge or, if the water/exhaust gas mixer solution is adopted, a conduit will connect the outlet of the last heat exchanger with the mixer inflow junction pipe.

Sea water pump

Figure 17

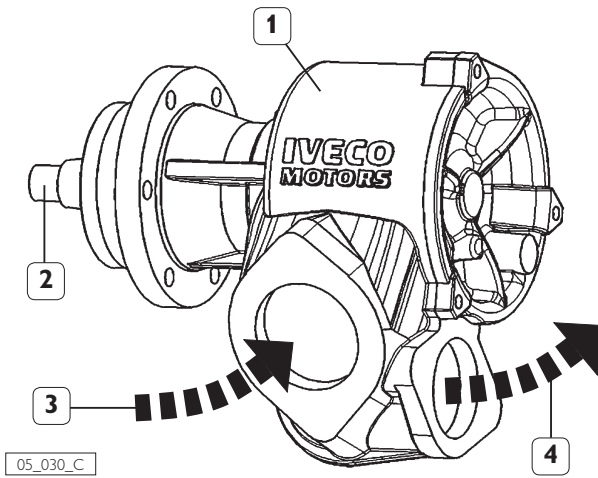

1. Pump impeller seat - 2. Driving gear shaft -
3. Sea water intake - 4. Sea water delivery.

The sea water pump, centrifugal type, is rotated by the gears keyed to the rear of the flywheel.

ENGINE OIL - LUBRICATION LOOP

Figure 18

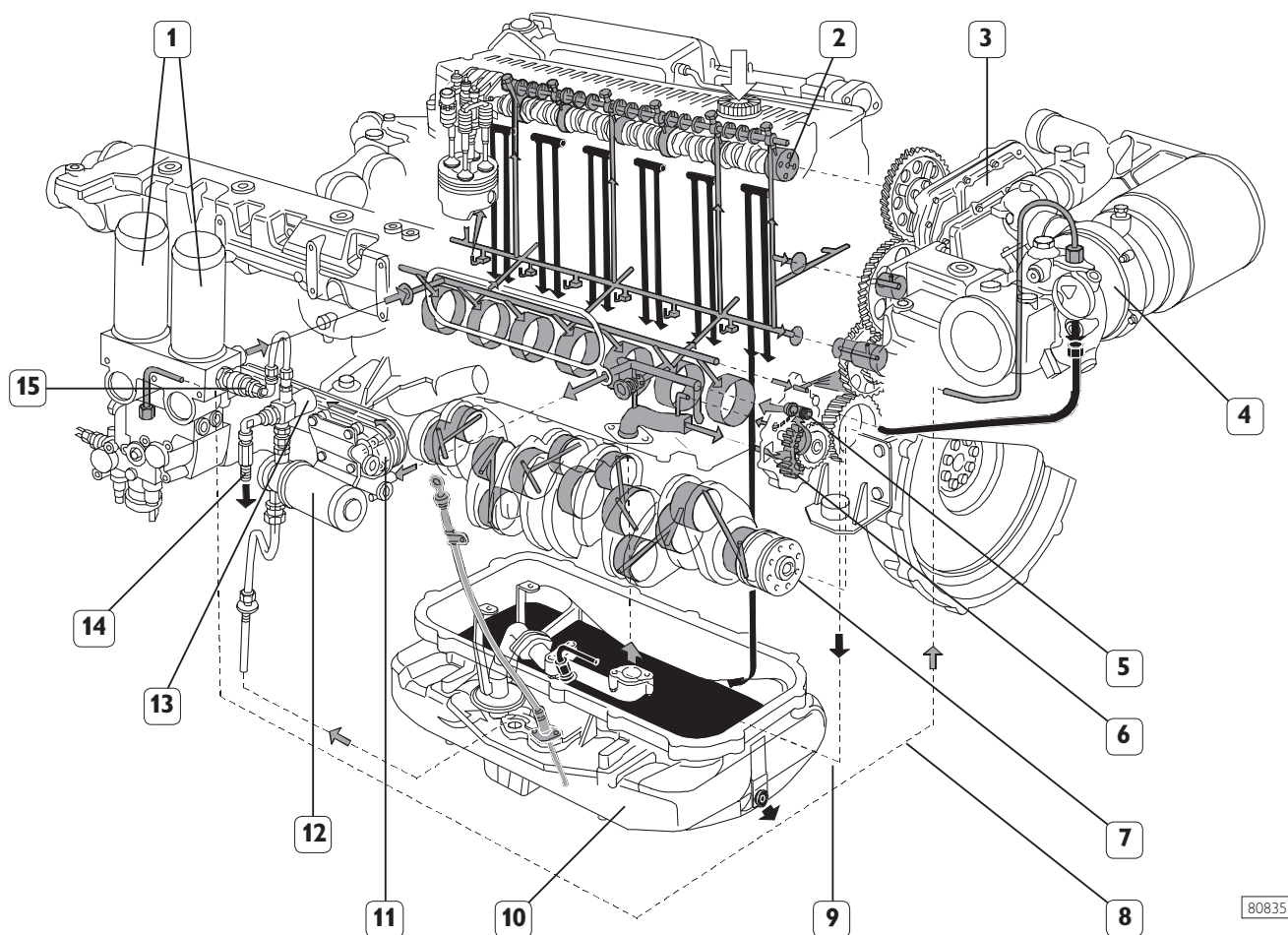

80835

Sump return oil

Delivery oil

1. Oil filters - 2. Camshaft on cylinder head - 3. Oil vapor condenser and filter (blow by) - 4. Turbocompressor - 5. Oil pump safety valve - 6. Lubrication oil pump - 7. Drive shaft - 8. Turbocompressor lubricating oil flow line - 9. Oil return flow from turbocompressor - 10. Oil sump - 11. Heat exchanger with coolant - 12. Electrical pump for pre-lubrication and oil filling/emptying (on request) - 13. Solenoid valve for switching between the pre-lubrication or oil filling/emptying functions (on request) - 14. Oil emptying junction - 15. One-way pre-lubrication valve.

Description and operation

The gear pump, rotated by the gears at the rear of the fly-wheel sends the lubricating oil directly to the heat exchanger which, incorporated in the block and lapped by the coolant, reduces temperature to maintain optimal lubricating capability. The thermostatic valve that regulates oil flow is located at the inlet of the heat exchanger, opening the bypass pipe if temperature falls below calibration temperature. From the output of the heat exchanger, the oil is sent to the filter assembly and from this back to the engine block to lubricate all anti-friction elements.

The blow-by vapor condenser, provided with filter and safety valve, is located on the upper part of the timing mechanism lid. The vapors, after returning to the liquid state, will flow from the vapor condenser into the sump. The engine is provided with the pre-lubrication system on request. This can inject enough oil into the engine's ducts to guarantee a totally safe start.

The operation of the electrical pre-lubrication pump (on request), is automatically controlled by the ECU electronic unit.

This system, with the aid of the flow-switching solenoid valve, also permits the oil sump to be emptied and filled.

Detailed descriptions of this operation are provided in Section 3.

Gear pump

Figure 19

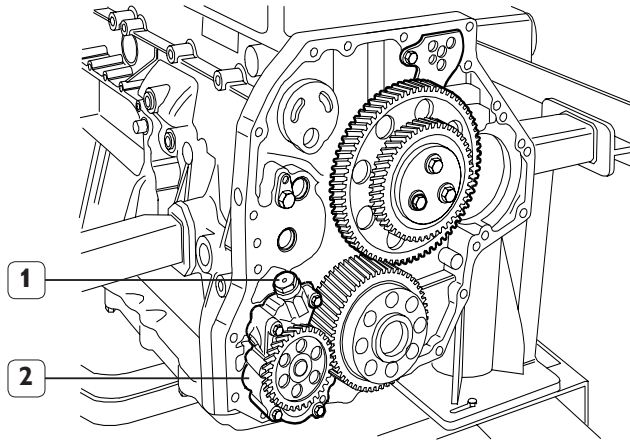

05_068_C

1.Safety valve - 2.Oil pump.

Oil vapor filter

Figure 20

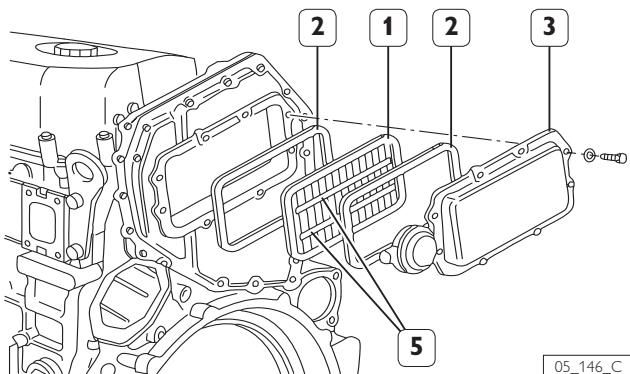

05_146_C

1.Oil vapour filter - 2. Gaskets- 3. Cover- 4. Exit of vapour from the motor extraction system - 5. Reinforcing bars

The oil vapours go through the filter (1) where their liquid parts condense and flow back in the sump whilst the remaining gas exits from the connection (4) and are sucked by the motor positioned after the air filter.

The filter (1) only works in one direction. Consequently it must be assembled with the two reinforcing bars (4) on the visible side, as shown in the picture.

Pre-lubrication system (on request)

Figure 21

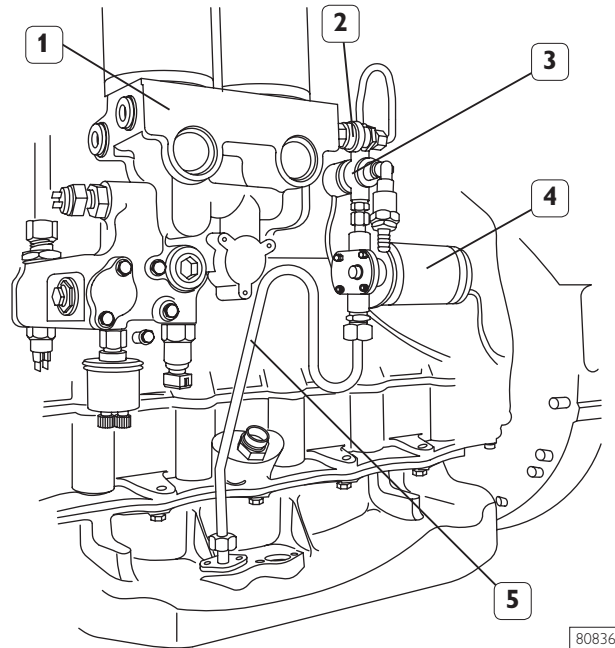

80836

1. Oil filter support - 2. One-way valve to prevent emptying - 3. Switching solenoid valve - 4. Electrical pump - 5. Oil sump inflow and suction pipe.

Commutable filters (on request)

Figure 22

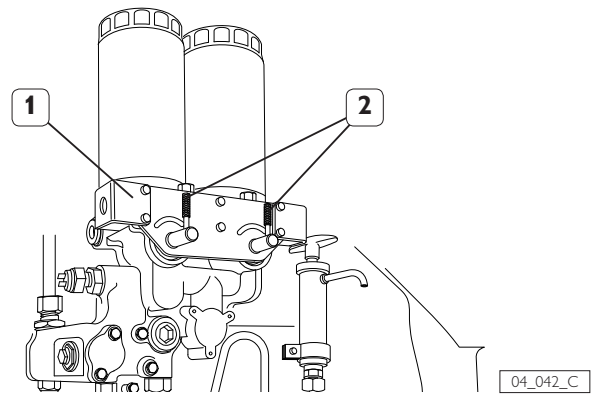

04_042_C

1. Commutable oil filters support- 2. Filters activation/ deactivation levers.

The supports are equipped with levers and, if necessary, they enable the replacement of a filter even if the motor is rotating. If necessary, operate very carefully to avoid risks of burning. Do not exclude both the filters together for any reason.

Thank you so much for reading.
Please click the “Buy Now!”
button below to download the
complete manual.



After you pay.

You can download the most
perfect and complete manual in
the world immediately.

Our support email:

ebooklibonline@outlook.com