

NEF ENGINE

N40 ENT M25

N60 ENT M37

N60 ENT M40

**TECHNICAL AND REPAIR
MANUAL**

MARCH 2007 EDITION

TECHNOLOGICAL EXCELLENCE

**IVECO
MOTORS**



SECTION CONTENTS

Section	Page
1. OVERVIEW	5
2. TECHNICAL DATA	53
3. ELECTRICAL EQUIPMENT	59
4. DIAGNOSTICS	95
5. MAINTENANCE	121
6. SERVICING OPERATIONS ON INSTALLED ENGINE	127
7. TOOLS	141
8. OVERHAUL	149
9. SAFETY REGULATIONS	217

Indications for consultation

The different engine versions are usually explained with common images and descriptions. In cases of considerable differences, they are explained separately.

Sections 1-2-3 are intended for sales personnel, to provide them with exact knowledge of the product's characteristics and enable them to meet the Customer's demands with precision.

The remaining sections are meant for personnel in charge of carrying out ordinary and extraordinary maintenance; with an attentive consultation of the chapter devoted to diagnosing, they will also be able to provide an effective technical assistance service.

CAUTION

During the year 2005, some modifications were made to the internal circuits of the relay box and to the wiring. These modifications make incompatible and harmful the use of the components supplied now together with the components supplied before. Please refer to the instruction shown in Chapter 8.

SECTION 1

OVERVIEW

	Page
IDENTIFYING DATA	7
COMMERCIAL CODE	8
PRODUCT MODEL NUMBER	9
ENGINE PARTS AND COMPONENTS	10
ENGINE ARCHITECTURE	12
Crankcase	12
Crankshaft	13
Connecting Rods	13
Pistons	14
Timing system driving gear	14
Cylinder head	16
Valves and valve seats	17
Ancillary machine members drive	17
COMBUSTION AIR INTAKE AND EXHAUST SYSTEM	18
Comburent air filter	19
Turbocompressor	19
Air/sea-water heat exchanger	19
COOLING FRESH WATER CLOSED-LOOP	20
Exhaust manifold cooling	21
Thermostatic valve	22
Water pump	22
Additional expansion tank	22
SEA-WATER OPEN COOLING LOOP	23
Sea-water pump	24
Sea-water/coolant heat exchanger	24

(continues on next page)

Page

Page

ENGINE OIL LUBRICATION LOOP	25
Gear pump	26
Filter bracket	26
Oil vapour recirculation	26
FUEL LINE	27
Fuel supply system scheme	28
Fuel pre-filter	29
Fuel filter	30
Pump assembly	31
Low pressure feed pump	32
Pressure control solenoid valve	34
Low pressure limiter valve	34
Pressure control with engine at maximum rating	35
Pressure control with engine at minimum rating	36
High pressure pump	37
Rail and high pressure piping	39
Two-stage overpressure valve	39
Electro-injectors	40
Pressurization valve of the electro-injector backflow	42
EDC 7 SYSTEM ELECTRONIC AND ELECTRIC MAIN COMPONENTS	43
EDC 7 Electronic Central Unit	44
Air pressure/temperature sensor	44
Atmospheric pressure sensor	44
Oil pressure/temperature sensor	45
Crankshaft sensor	45
Camshaft sensor	46
Coolant temperature sensor	46
Fuel temperature sensor	47
Fuel pressure sensor	47
Pressure control solenoid	48
Throttle lever position	48

SYSTEM FUNCTIONS	49
Run up	49
Starting	49
Metering and fuel injection	49
Injection advance management	49
Pre-injection	50
Injection pressure modulation	50
Idling adjusting	50
Self-diagnosis	50
EDC indicator light	50
Fuel heating	50
Linearization of the acceleration gradient	50
Balance of the cylinder torque delivery	50
Rotation speed control	50
Top speed limitation	50
Cut off	50
Derating	51
Recovery	51
After run	51

IDENTIFYING DATA (up to December 2003)

Figure 1

IVECO <i>aifo</i> S. p. A.	
Viale dell' Industria, 15/17 - 20010 Pregnana Milanese MI - ITALY	
ENGINE TYPE	<input type="text" value="N60ENTM37"/>
DATA SET REF.	<input type="text" value="A71110STD"/>
ENGINE S/N	<input type="text" value="000000"/>
ENGINE DRW	<input type="text"/>
HOMOLOGATION	<input type="text"/> N° <input type="text"/>
COMMERC. TYPE / VERSION	<input type="text" value="N60ENTM37"/> <input type="text" value=".10"/>
<i>Industrial & Marine engine</i>	

04_004_N

IDENTIFYING DATA (from January 2004)

Figure 2

IVECO S. p. A.	
Viale dell'Industria, 15/17 - 20010 Pregnana Mil.se MI - ITALY	
ENGINE TYPE	<input type="text"/>
ENGINE FAMILY	<input type="text"/>
ENGINE DWG	<input type="text"/>
POWER (KW) AND SPEED (RPM)	<input type="text"/>
POWER SET CODE	<input type="text"/>
ENGINE S/N	<input type="text"/>
YEAR OF BUILD	<input type="text"/>
HOMOLOGATION	<input type="text"/> N° <input type="text"/>
COMMERC. TYPE / VERSION	<input type="text"/> <input type="text"/>

04_002_N

Figure 3

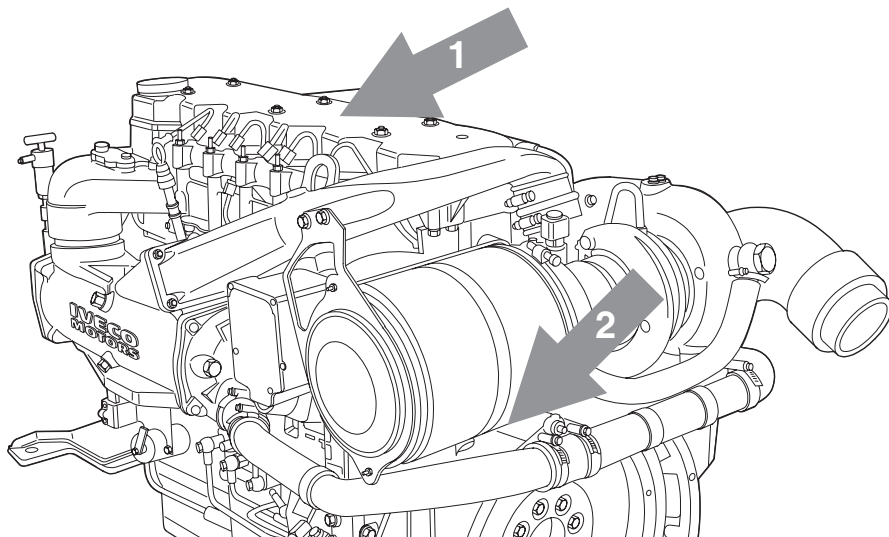

04_007_N

COMMERCIAL CODE

The purpose of the commercial code is to make the characteristics of the product easier to understand, categorizing the engines according to their family, origins and intended application. The commercial code, therefore, cannot be used for the technical purpose of recognizing the engine's components, which is served by the "ENGINE S/N".

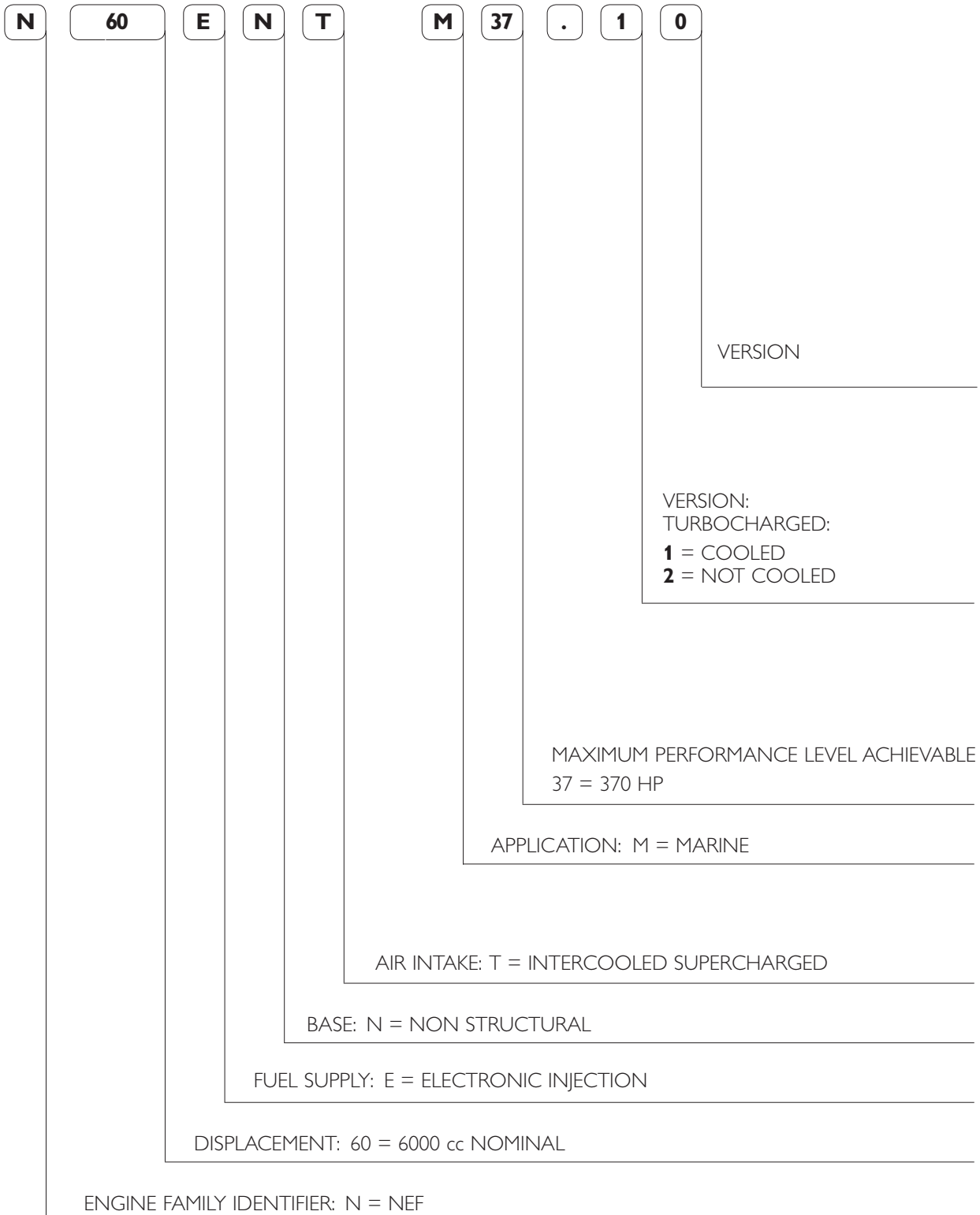

PRODUCT MODEL NUMBER

The model number is assigned by the manufacturer; it is used to identify the main characteristics of the engine, and to characterize its application and power output level. It is stamped on a side of crank-case, close to oil filter.

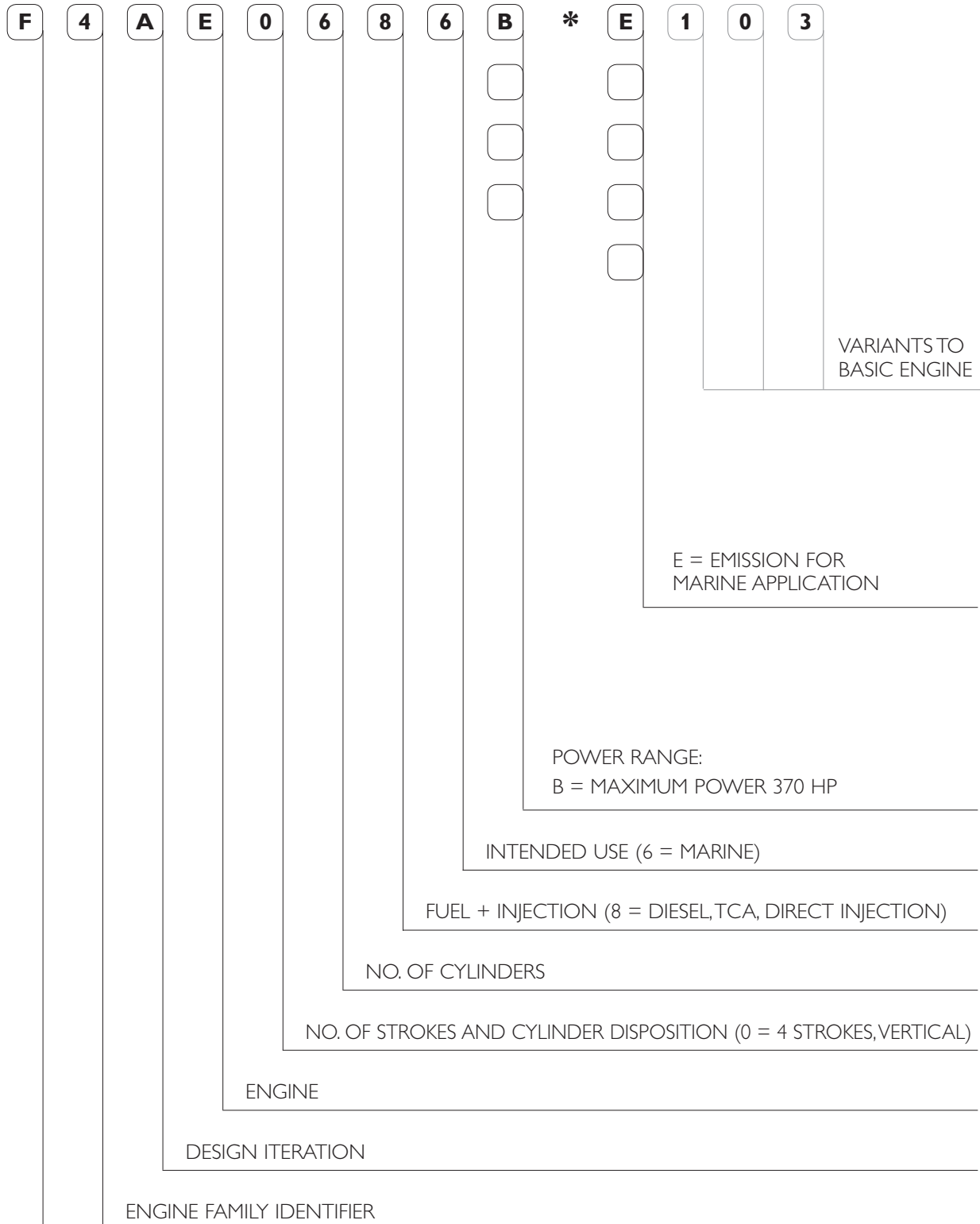

ENGINE PARTS AND COMPONENTS

Figure 4

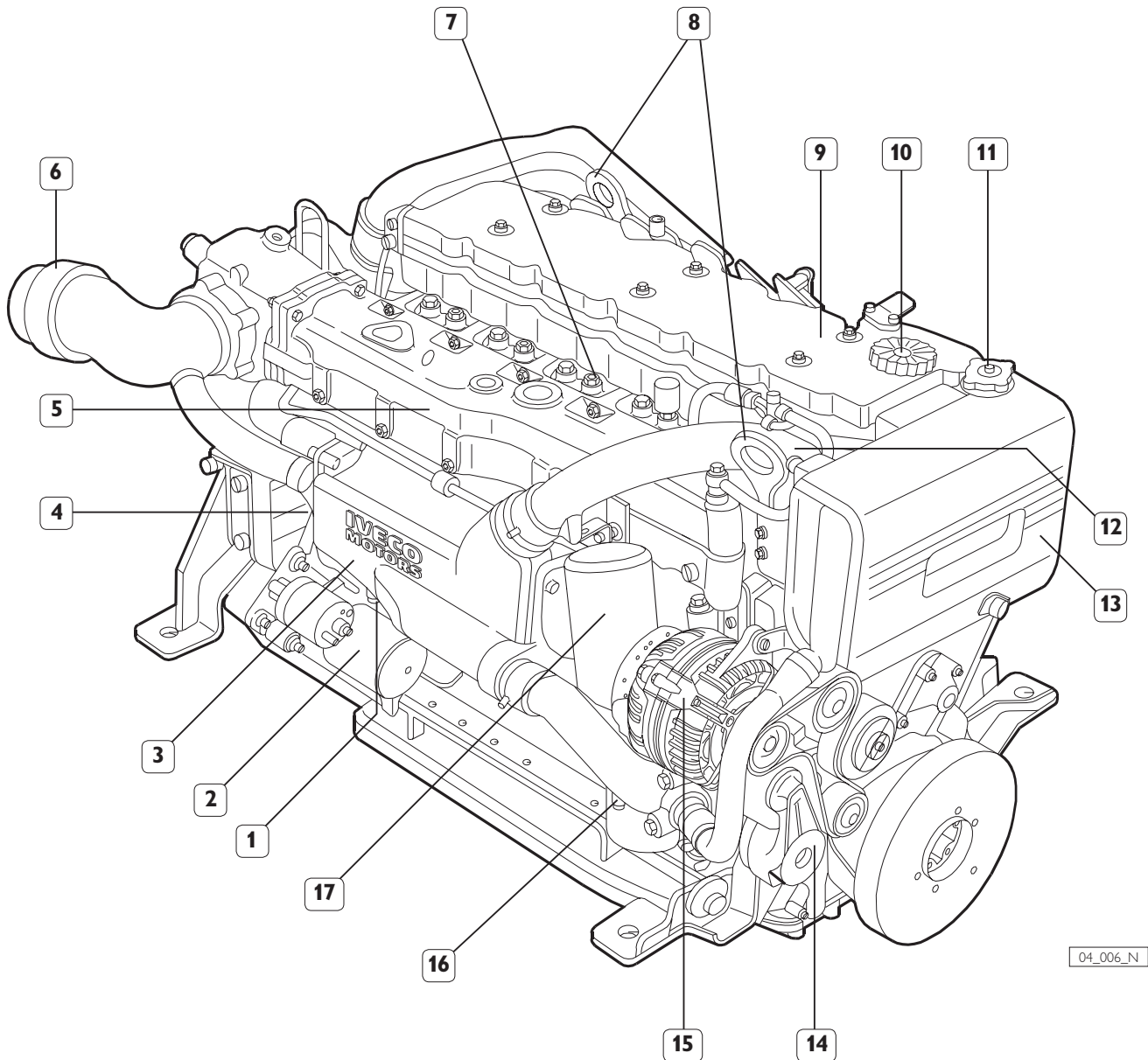

04_006_N

1. Engine coolant discharge cap - 2. Electric starter motor - 3. Tube bundle engine coolant/sea-water heat exchanger - 4. Location of sacrificial anode - 5. Cooled exhaust manifold - 6. Exhaust gas and sea-water discharge pipeline - 7. Cap for engine coolant outlet to sanitary water heating system - 8. Lifting eyebolts - 9. Rocker arm cover - 10. Oil refill cap - 11. Coolant refill cap - 12. Location of thermostatic valve - 13. Engine coolant tank - 14. Auxiliary belt automatic tensioner - 15. Alternator - 16. Cap for engine coolant discharge and recirculation from sanitary water heating system - 17. Oil filter.

Figure 5

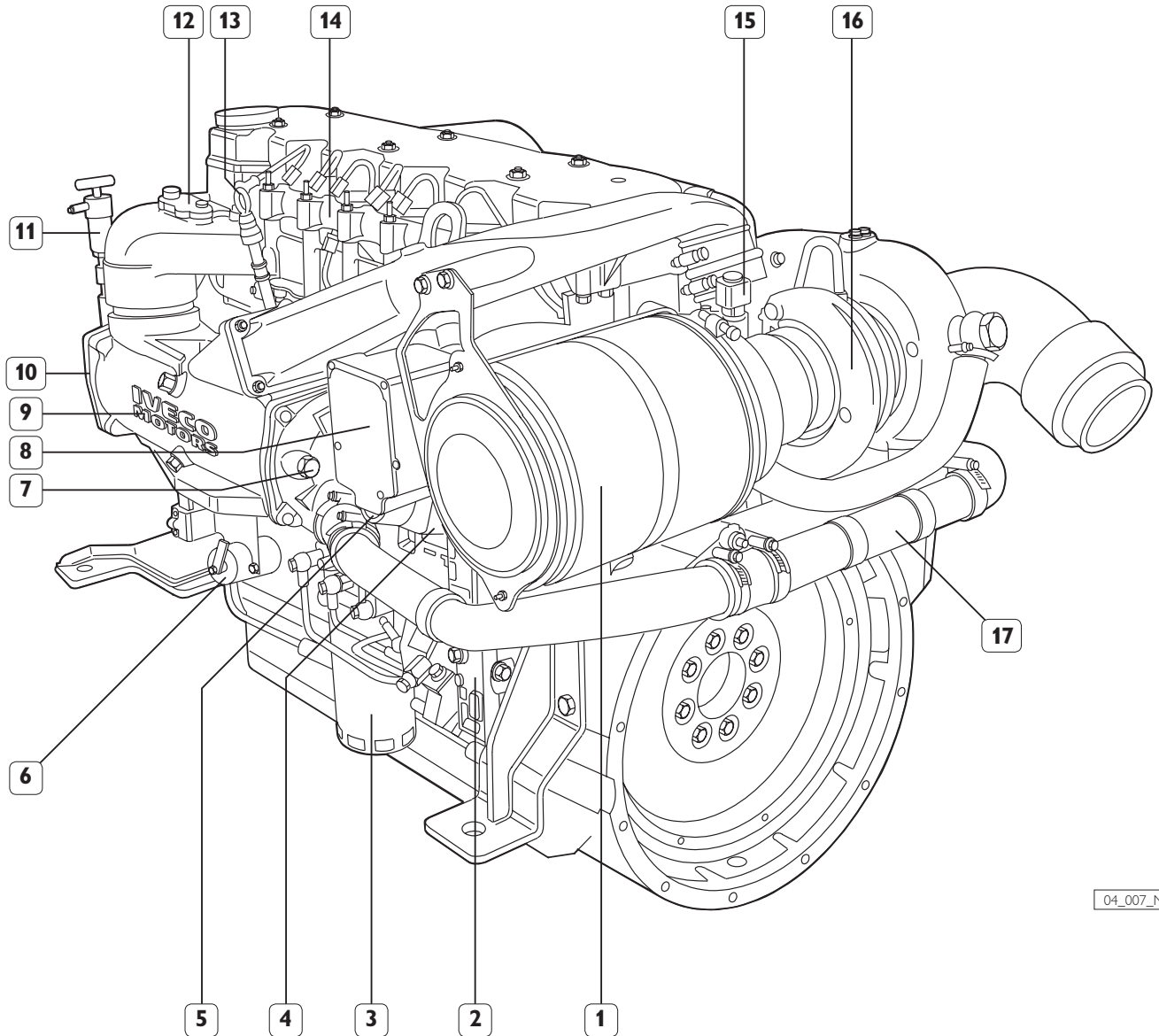

04_007_N

1. Combustion air filter - 2. Common rail high pressure injection pump - 3. Fuel filter - 4. Sea-water pump - 5. Sea-water inlet - 6. Throttle potentiometer - 7. Sacrificial anode - 8. Oil vapor separator - 9. Combustion air/sea-water heat exchanger - 10. Location of sea-water discharge cap - 11. Manual lubricating oil extraction pump - 12. Combustion air pressure and temperature sensor - 13. Oil dipstick - 14. Common rail distributor - 15. Air filter clogging sensor - 16. Cooled turbocompressor - 17. Sea-water junction pipe from after-cooler to engine coolant/sea-water heat exchanger.

ENGINE ARCHITECTURE

NEF engines are the highest expression of design and engineering efficiency that IVECO MOTORS-FPT makes available on the market place. They are highly innovative engines designed to be able to comply now with the regulations on fumes and acoustic emissions that will be enforced in the near future.

Designed with innovative techniques and manufactured with advanced working processes, they are the result of hundreds of years of design and engineering tradition as well as of an important international cooperation.

The excellent performance of NEF engines originates from induction and exhaust ducts of new design where, by improving the gas exchange phases, the intaken air turbulence is improved, thus enabling the complete exploitation of the new injection system capacity.

The new criteria chosen in defining the parameters setting the combustion conditions, metering and injection, optimized instant by instant, enable to obtain a new balance between high performance and consumption reduction. NEF engines can be fitted with a mechanical pump or a total electronic controlled "Common Rail" fuel supply system.

Every technical solution has been accurately devised so as to assure qualitative product perfection. The configuration of the engine itself has been designed in such a way as to facilitate access to each individual part thus reducing maintenance time.

Cylinder head fitted with four valves per cylinder; rear timing control, new design connecting rods and aluminum-nickel pistons are components of an engine fitted with 40% less elements than an engine of equivalent performance.

Crankcase

Figure 6

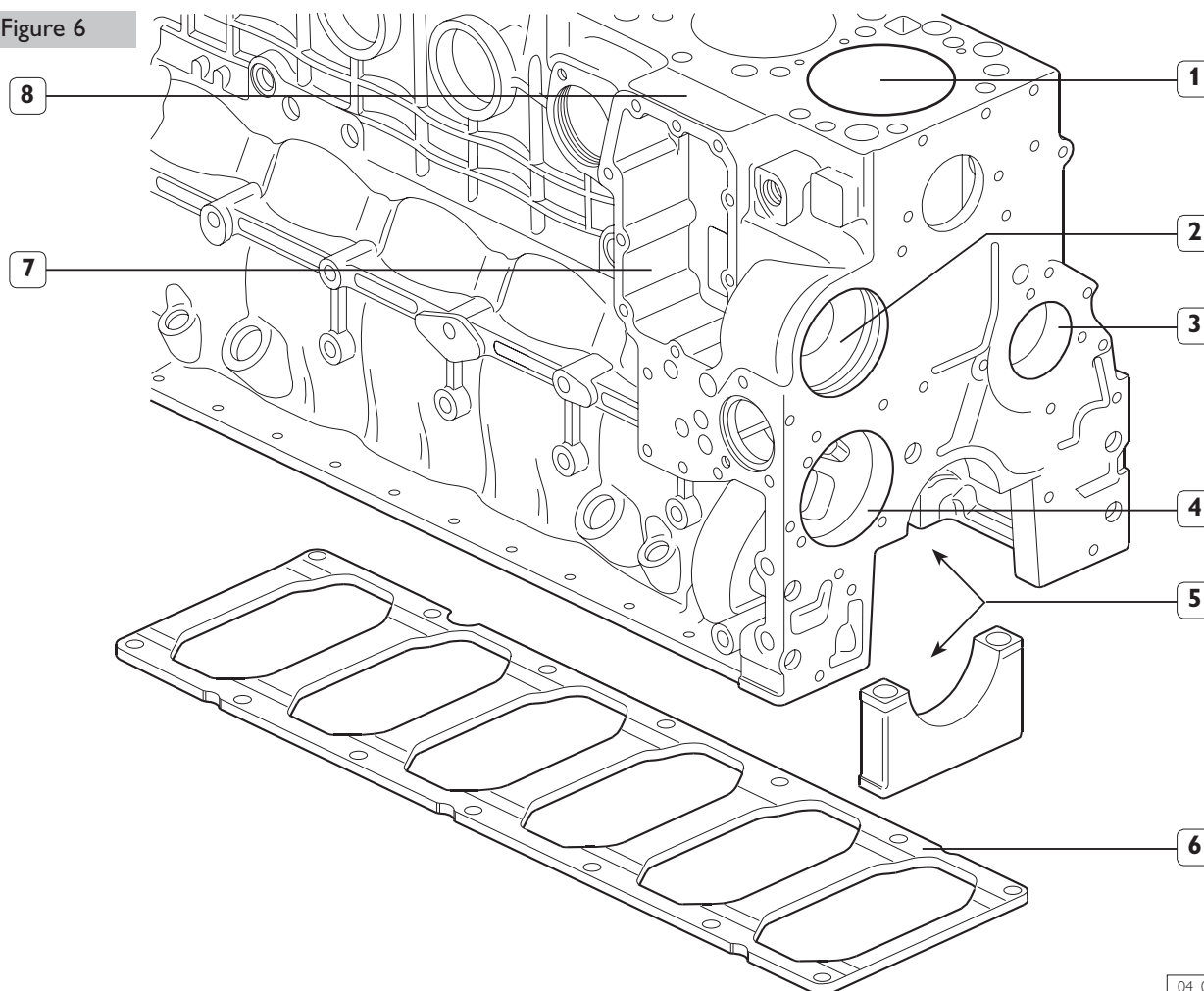

04_011_N

1. Reconditionable integral cylinder barrels - 2. Water pump seat - 3. Camshaft bushing seat - 4. Oil pump seat - 5. Main bearings - 6. Crankcase backing plate - 7. Oil cooler (water/oil) seat - 8. Product model number location.

Moreover, within the cast iron crankcase, coolant circulation grooves, ducts for lubrication loops for the various machine parts and the seat for push rod bushings have

been grooved in. The backing plate (6) applied to the lower part makes the crankcase tougher and improves resistance to stress.

Crankshaft

Figure 7

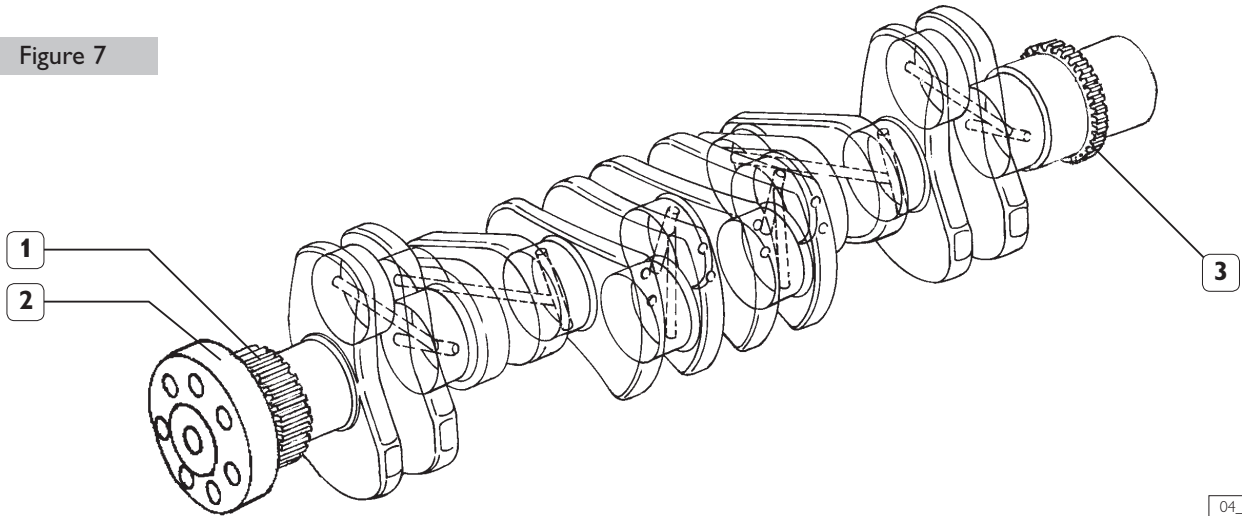

1. Timing system driving gear - 2. Flywheel connecting hub - 3. Oil pump driving gear.

04_012_N

The crankshaft is made in steel hardened by induction and rests on seven mountings; inside the hollow shaft are the ducts for the lubrication oil circulation.

On the front tang, the oil pump driving gear, the phonic wheel, the flywheel connecting hub and the driving pulley of the ancillary components are keyed on.

On the rear tang the camshaft driving gear and the coupling flange to the engine flywheel are keyed on.

The bench half bearings are in cast babbitt lining steel and the 6th is fitted with a shoulder ring to contain the end play of the driving shaft.

Components 1 and 2 in the figure, assembled by negative allowance on the rear tang, are not replaceable. The front and rear retaining rings are of the slide type with radial seal and require special fixtures to be assembled and disassembled.

Connecting Rods

Figure 8

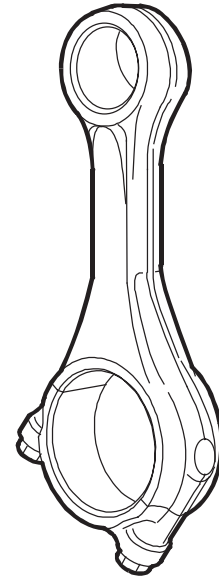

04_013_N

They are made in steel, manufactured by pressing, with small end oblique edged and cap separation obtained by fracture splitting technique.

The connecting rod half bearings are cast babbitt lining steel.

Every connecting rod is marked on the body and on the cap by a number that identifies their coupling and the cylinder into which it is to be assembled; moreover, a letter is impressed on the body stating its weight class.

In case a replacement were necessary, only one type of connecting rod is available as spare part of an intermediate class weight that can be used to replace any other. Therefore, connecting rods that are still efficient, do not need to be replaced even if they are of a different class weight.

Pistons

Figure 9

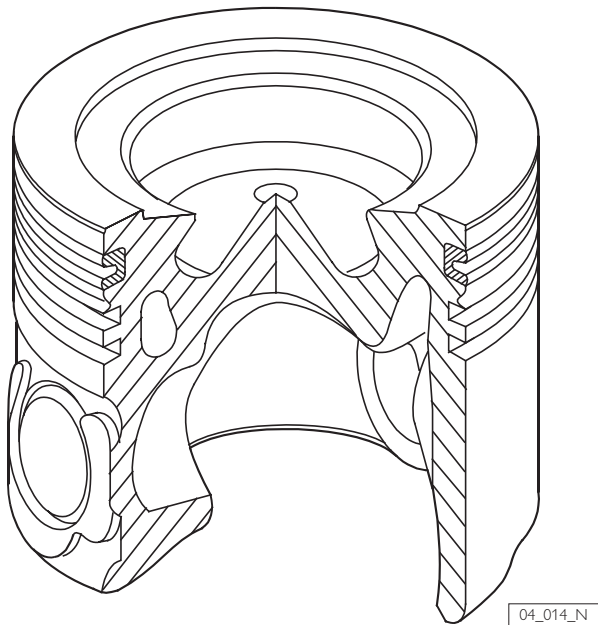

The pistons integrate the high swirl combustion chamber; the annular chambers inside the junk ring enable an effective heat elimination obtained by circulating the lubrication oil delivered by the spray nozzles mounted on the crankcase. On the piston skirt the are three seats for the retaining rings; the first one of these is obtained by a special trapezoidal section cast iron insert.

The piston rings have different functions and different geometry.

- The 1st piston ring has a trapezoidal section and ceramic chrome plating;
- The 2nd piston ring has a a torsional conical rectangular seal;
- The 3rd piston ring has a double oil scraper with internal spring.

Timing system driving gear

Figure 10

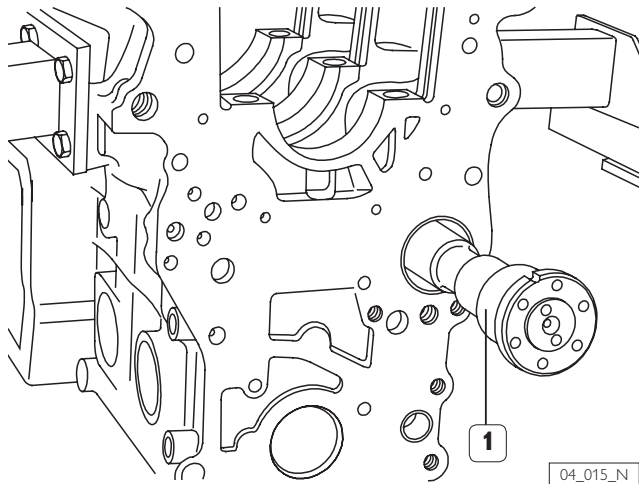

The timing system driving gear machine is a push rods and rockers type, with a camshaft (1) that is located in the crankcase and set into rotation directly by the crankshaft.

Figure 11

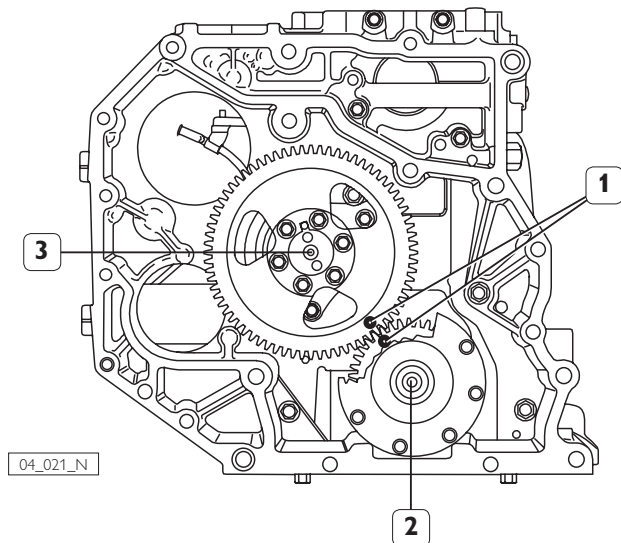

1. Positioning reference - 2. Crankshaft - 3. Camshaft.

The figure illustrates the position that the toothed wheel has to have to set the correct timing strokes.

Figure 12

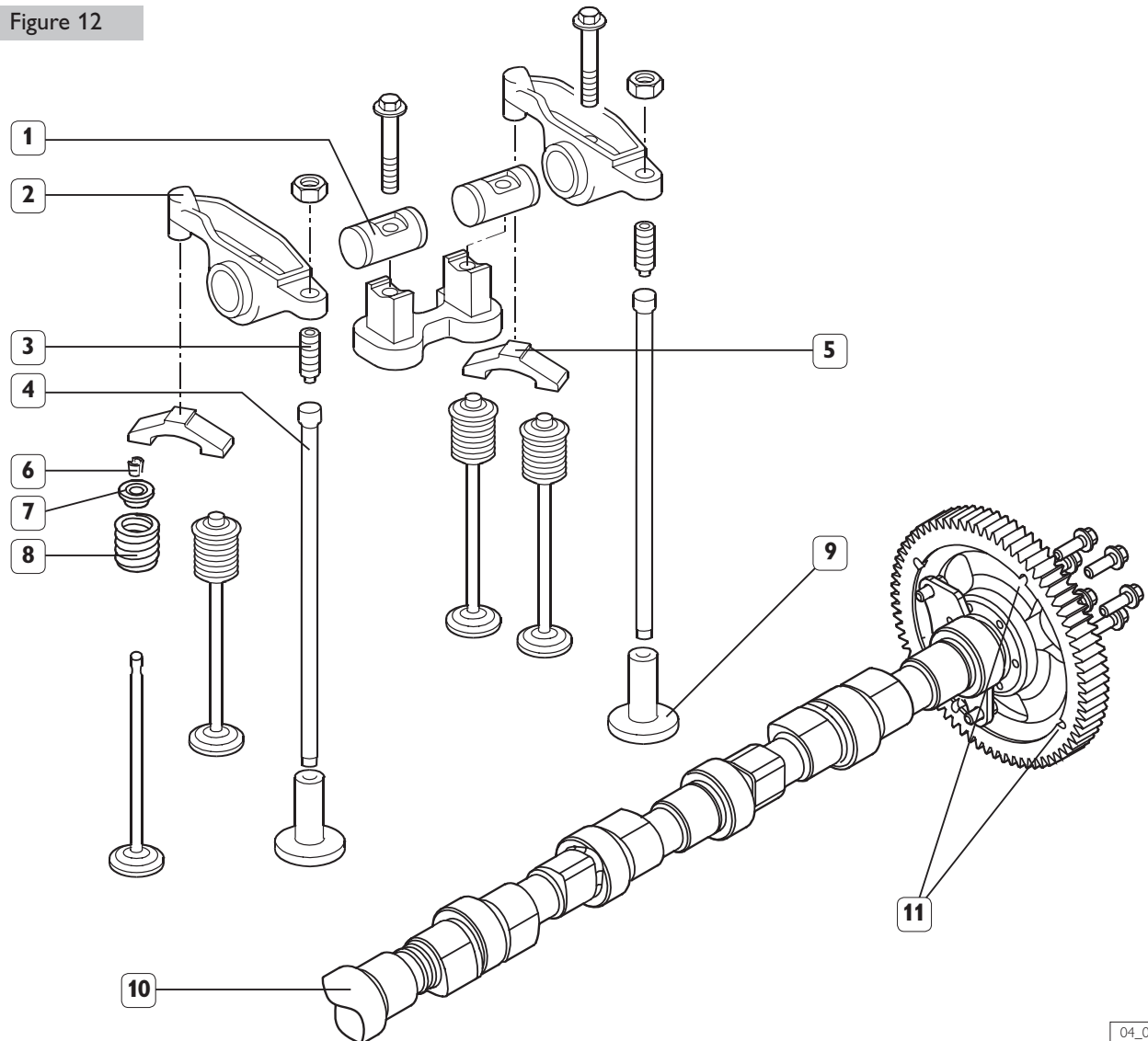

04_016_N

1. Spindle - 2. Rocker - 3. Adjuster screw - 4. Rod - 5. Bridge - 6. Cotters - 7. Cup - 8. Spring - 9. Tappet - 10. Camshaft -
11. Holes for camshaft sensor.

The timing camshaft rests on seven mountings; the mounting points at the front and rear end are fitted with cast babbitt lining steel bushings, assembled by negative allowance.

The timing camshaft is set into rotation by the crankshaft with direct coupling to a straight toothed wheel. The toothed wheel keyed on the timing camshaft has 6+1 slots for camshaft sensors (11) enabling the generation of the electric signals needed for the engine control system.

Cylinder head

Figure 13

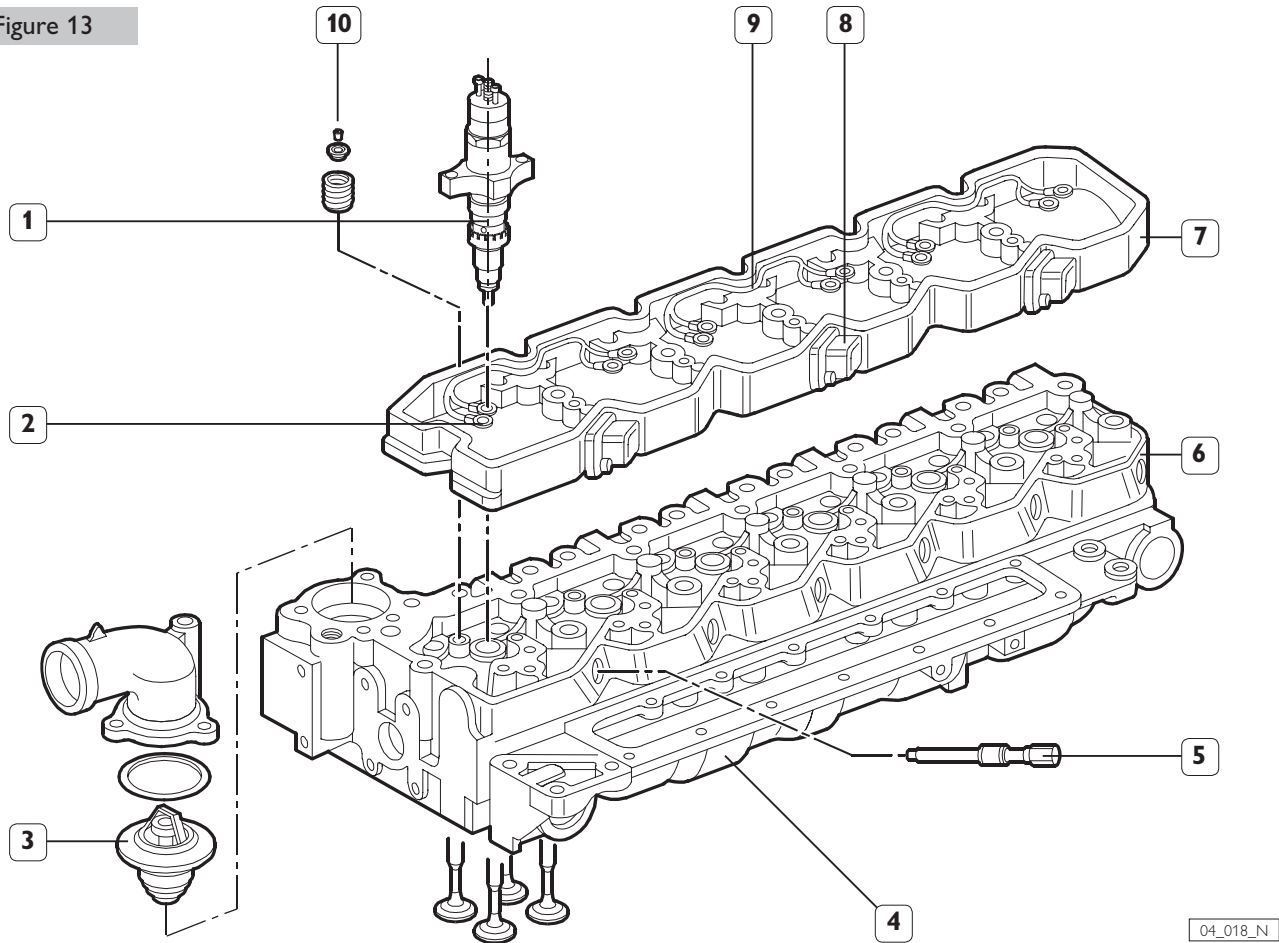

04_018_N

1. Electro-injector - 2. Electro-injector electric connection terminal - 3. Thermostat valve - 4. Induction manifold - 5. Fuel filling pipe to the injector - 6. Cylinder head - 7. Chassis bracket for injectors electric outfit - 8. Electric connector - 9. Electro-injector wiring harness - 10. Cotter, cup and spring.

The cylinder head is monolithic and is made in cast iron; it houses slots for the following:

- Valves, with seats and elements inserted;
- Thermostatic valve;
- Electro-injectors;
- Fuel delivery filling pipes connections to the electro-injectors.

Inside the cylinder head the duct for the recovery of the fuel not used by electro-injectors has been fitted.

- Exhaust manifold;
 - Induction manifold
- are coupled to the cylinder head.

On the top part of the head the chassis is secured, to which the connectors of the wiring harness for the control of electro-injectors, are fastened.

Valves and valve seats

Figure 14

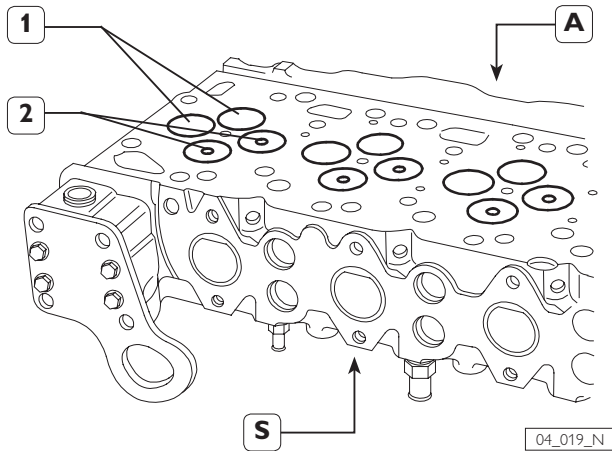

1. Induction valves - 2. Exhaust valves - 3. Inserted element -
A. Induction side - S. Exhaust side.

Valves seat are obtained by casting in the cylinder head, and machined to 45° taper ratio for exhaust valves and 60° taper ratio for induction valves.

Ancillary machine members drive

Figure 15

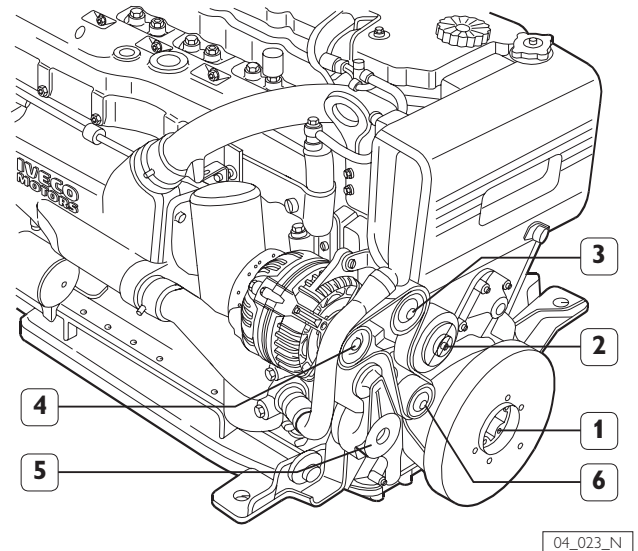

1. Crankshaft - 2. Engine coolant pump pulley - 3. Stationary
guide pulley - 4. Alternator pulley - 5. Spring tightener -
6. Stationary guide pulley.

Motion to ancillary machine parts is transmitted by a Poly - V belt put under tension by a gauged spring (5). Stationary guide pulley (3) is located between the alternator pulley and the engine coolant pump pulley in order to provide an adequate contact surface on the latter.

Thank you so much for reading.
Please click the “Buy Now!”
button below to download the
complete manual.



After you pay.

You can download the most
perfect and complete manual in
the world immediately.

Our support email:

ebooklibonline@outlook.com