

SOFIM ENGINE

S30 ENT M23

**TECHNICAL AND REPAIR
MANUAL**

MARCH 2007 EDITION

TECHNOLOGICAL EXCELLENCE

**IVECO
MOTORS**



IDENTIFYING DATA

Figure 1

IVECO S. p. A. Pregnana Plant			
Viale dell'Industria, 15/17		20010 Pregnana Milanese MI - Italy	
ENGINE TYPE	F1CE0486A*A001		
ENGINE FAMILY	S30 ENTM	ENGINE DWG	8039943
POWER (KW) AND SPEED (RPM)	169/4000	POWER SET CODE	
ENGINE S/N	1318	YEAR OF BUILD	2006
HOMOLOGATION		N°	
COMMERC. TYPE / VERSION	S30ENTM23		.10

06_004_S

Figure 2

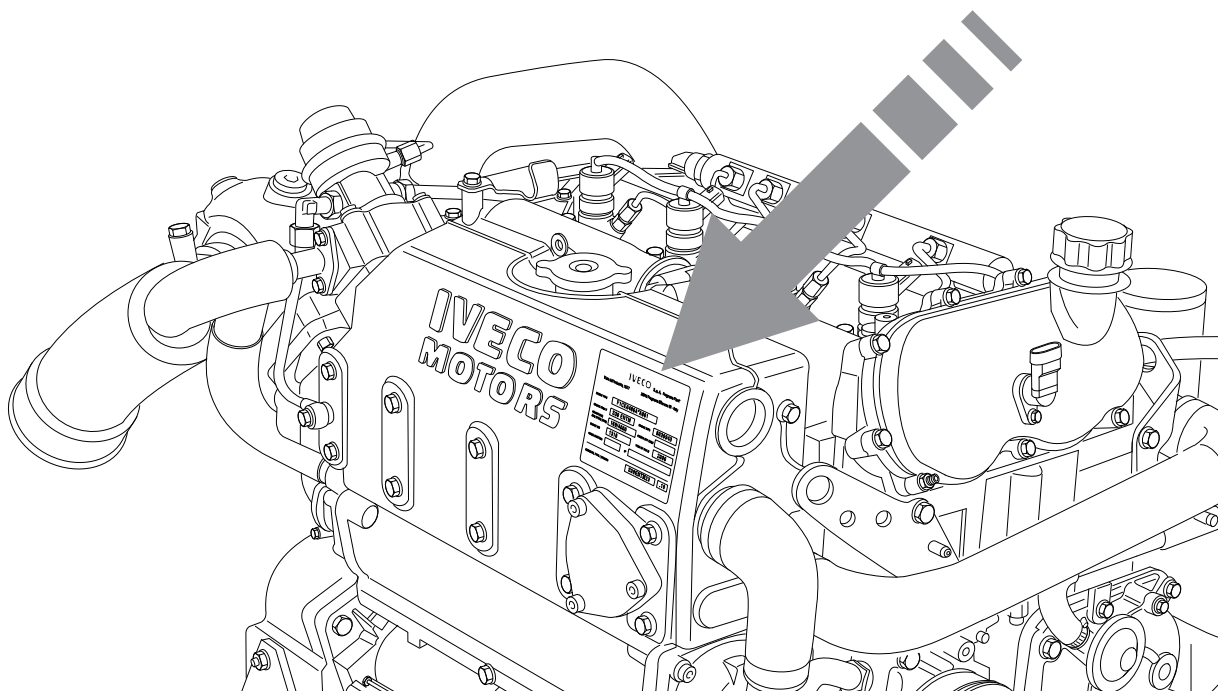

05_003_S

The engine identification data are stenciled on a tag positioned over the engine coolant tank

COMMERCIAL CODE

The purpose of the commercial code is to make the characteristics of the product easier to understand, categorizing the engines according to their family, origins and intended application. The commercial code, therefore, cannot be used for the technical purpose of recognizing the engine's components, which is served by the "ENGINE S/N".

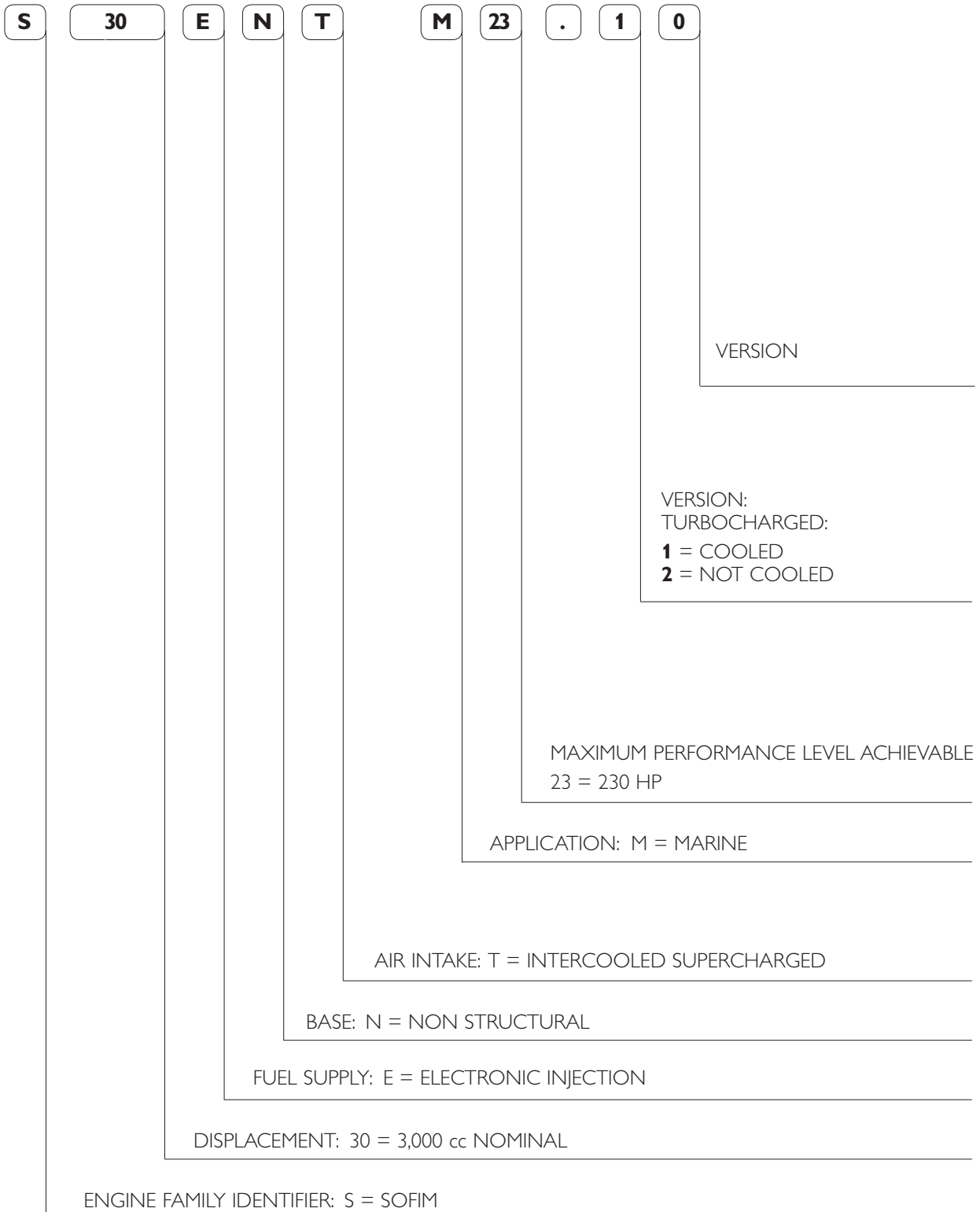

ENGINE PARTS AND COMPONENTS

Figure 3

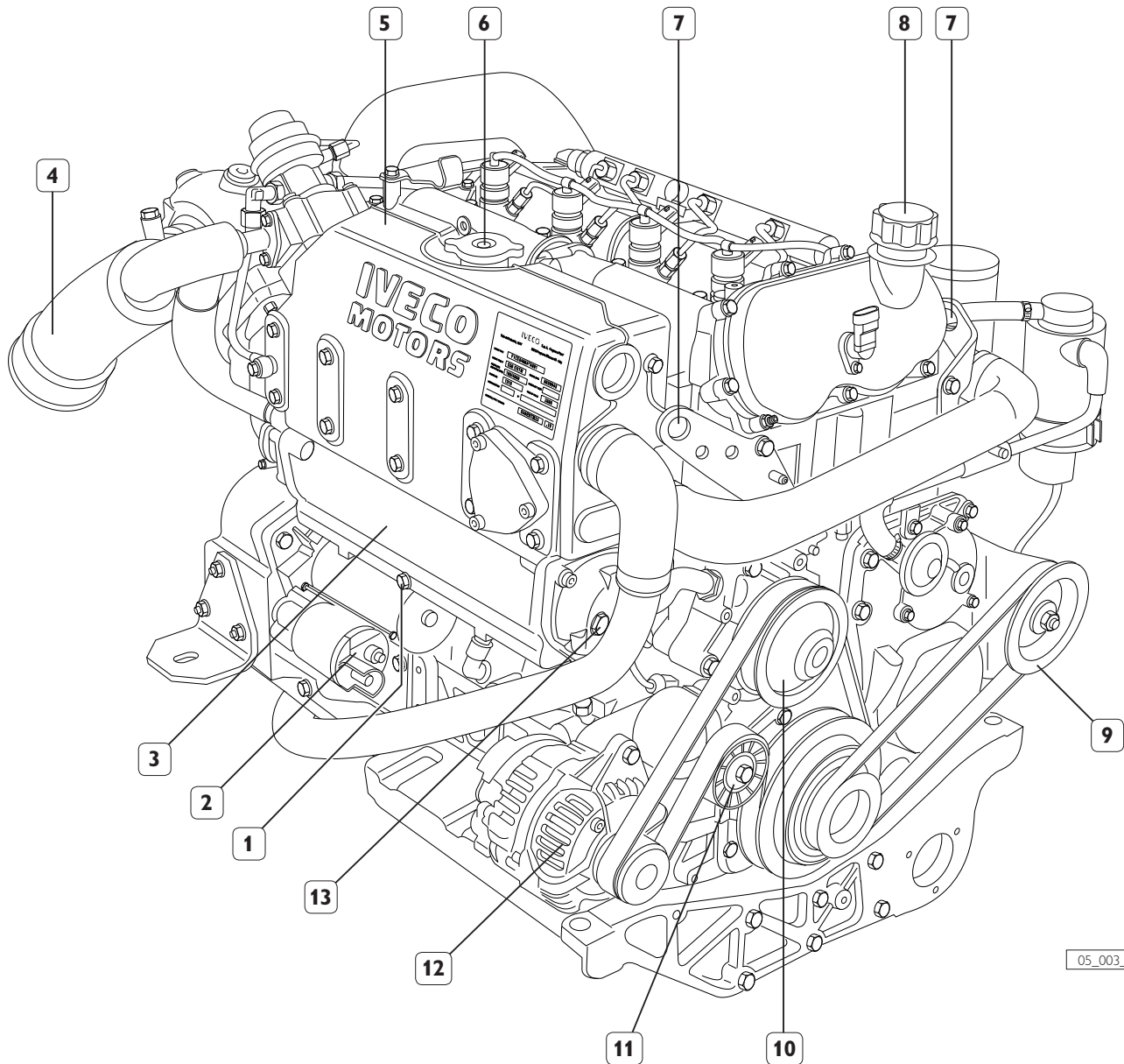

05_003_S

1. Engine coolant discharge cap - 2. Electric starter motor - 3. Tube bundle engine coolant/sea water heat exchanger - 4. Exhaust gas and sea water discharge pipeline - 5. Engine coolant tank - 6. Coolant refill cap - 7. Lifting eyebolts - 8. Oil refill cap - 9. Sea water pump actuation pulley - 10. Engine coolant pump control pulley - 11. Auxiliary belt automatic tensioner - 12. Alternator - 13. Location of sacrificial anode.

Figure 4

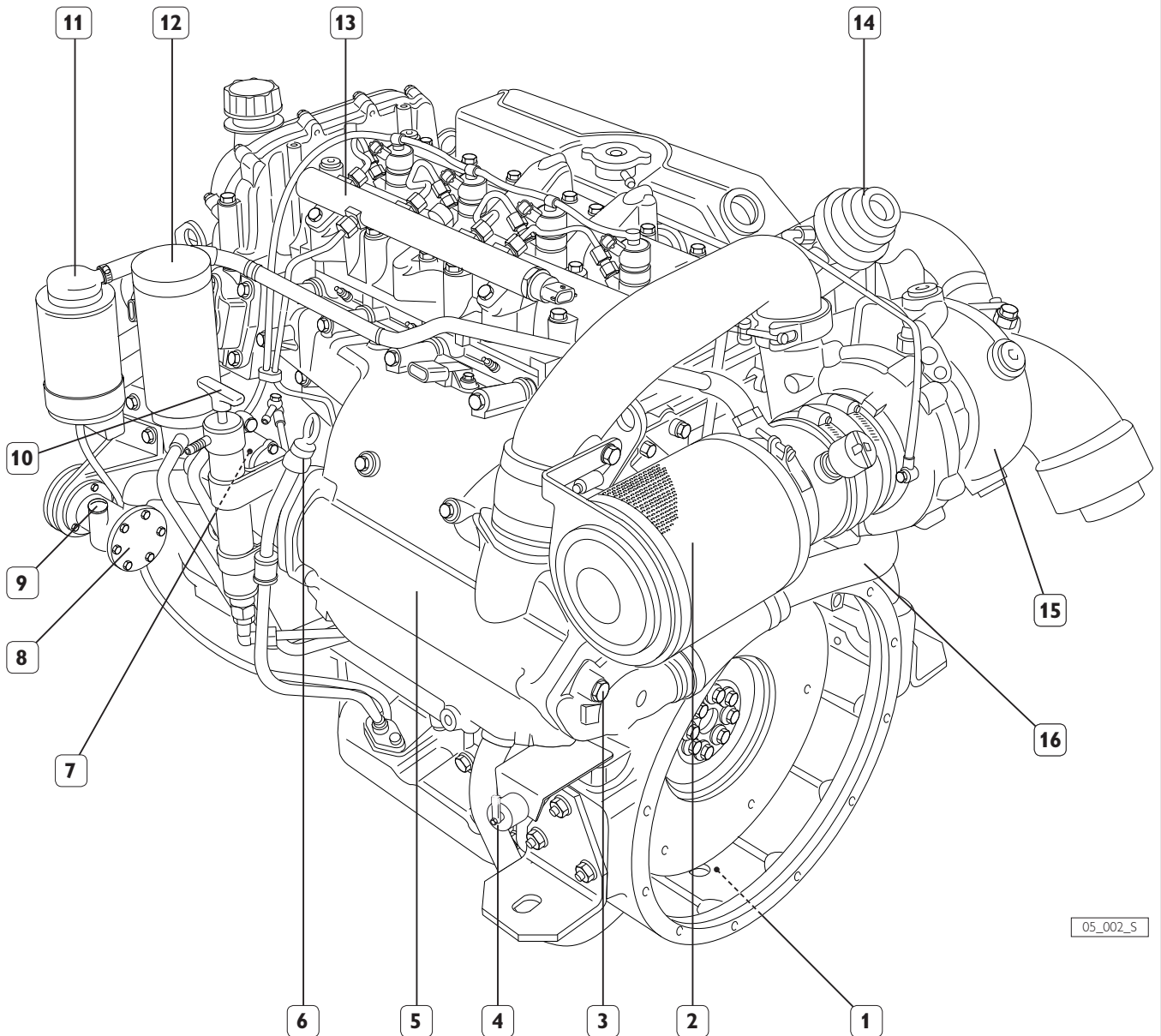

05_002_S

1. Engine coolant discharge cap location - 2. Combustion air filter - 3. Sacrificial anode - 4. Throttle potentiometer - 5. Combustion air-sea water heat exchanger - 6. Oil dipstick - 7. Location of common rail high pressure injection pump - 8. Sea water pump - 9. Sea water inlet - 10. Manual lubricating oil extraction pump - 11. Oil vapor separator - 12. Lubricating oil filters - 13. Common rail distributor - 14. Waste-gate actuator - 15. Cooled turbocharger - 16. Sea water junction pipe from after-cooler to engine coolant/sea water heat exchanger.

ENGINE ARCHITECTURE

The new light IVECO MOTORS-FPT diesel engines improve the excellence of the already well-known SOFIM engine and they position themselves on top of the 2.3 and 3 lt categories for performance, reliability and efficiency. Both adopt highly efficient technical solutions, which are at the origin of their excellent performances. Their high torque, available at high and slow rpms, and their considerable power are optimized for any usage profile and allow a global efficiency which is unparalleled for any application. Designed to comply also with future norms on gas emission and noise containment, they represent the synthesis of the most recent technologies and they are manufactured according to ISO 9002 quality standards.

The very high injection pressure of the new "Common rail" perfectly atomizes and distributes the fuel in the consider-

able air mass provided by turbochargers, in order to create homogeneous mixes, whose combustion generates optimal heat release and it ensures high performances for any mission.

The double overhead camshaft and the hydraulic valve control, up until now used on engines designed for high range vehicles, ensure constant performances over time and reduce noise and maintenance requirements. Internally-refrigerated supercharging generated by turbochargers fitted with waste-gate or VGT valves, provides a timely response to acceleration. An extensive variety of options and the undisputed experience in kinematic chains, allow the IVECO MOTORS-FPT to meet any individual need of the customer.

Crankcase

Figure 5

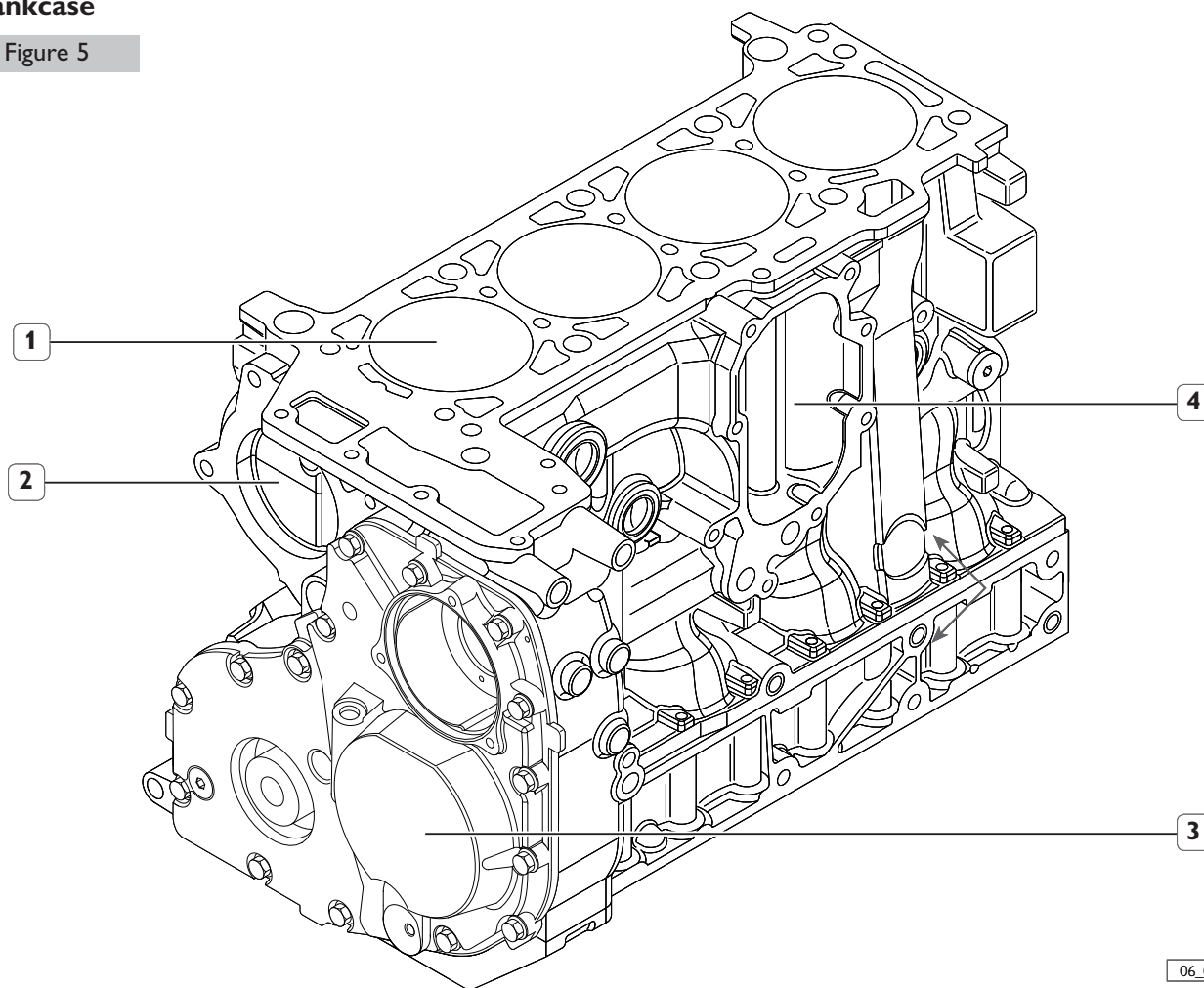

06_086_S

1. Reconditionable integral cylinder barrels - 2. Water pump seat - 3. Oil pump seat - 4. Oil cooler (oil/water) seat.

The engine block is a cast iron structure housing the cylinder liners (with "plateau" finishing), main bearings and the coolant pump seat. Furthermore, the engine block houses the coolant recirculation chambers and the lubrication

circuit ducts of the various gears. Cylinder liners will be increased by 0.4 mm.

Crankshaft

Figure 6

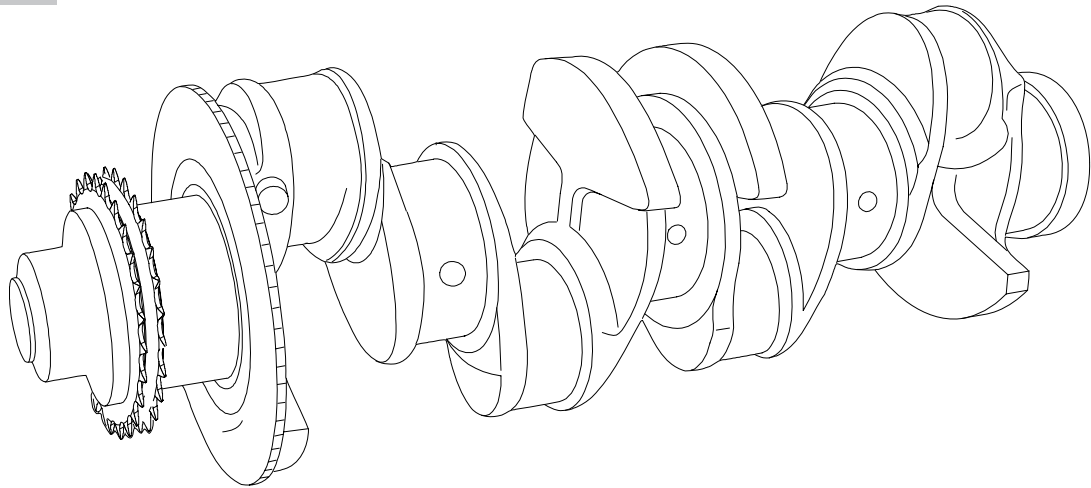

06_011_5

1. Auxiliary gears and distribution control double chain gear.

The cast iron driving shaft rests on five bearings; inside, it houses lubrication oil circulation ducts.

The shaft end is fitted with auxiliary gears and distribution chain gears such as the high pressure feeding pump and the oil pump is fitted with a depressor (G.P.O.D. group).

Main half bearings are made of steel coated with anti-friction alloy.

Front and rear sealing rings are of slide type with radial seal and special tools are required for their assembly and disassembly.

Figure 7

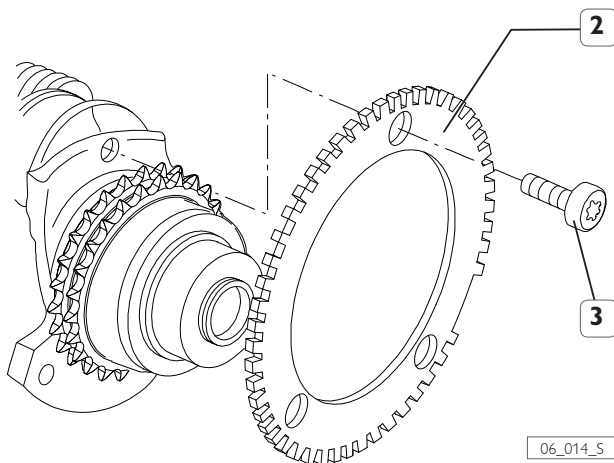

06_014_5

The shaft end is also fitted with a phonic wheel (2) fastened by screws (3) and Loctite 218 which need replacement after every disassembly procedure.

Connecting rods

Figure 8

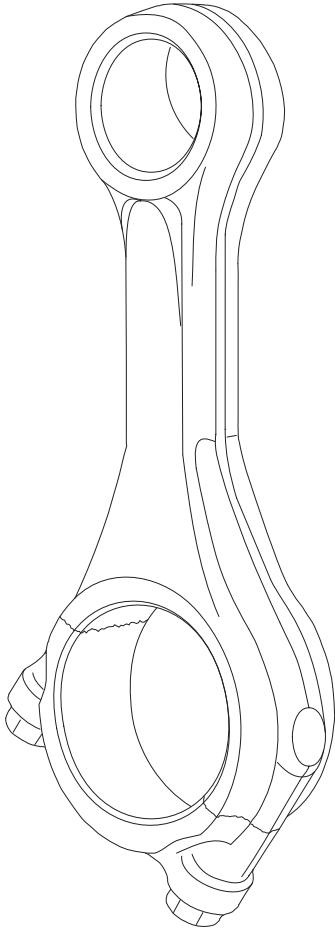

06_088_S

Made out of steel, they are stamped with a skew cut small end and separation of the cap obtained through a fracture technique.

Connecting rod half bearings are made of steel and coated with anti-friction alloy.

Each connecting rod is stamped on the casing and on the cap with a number which identifies their coupling and the cylinder in which it is assembled; furthermore, its weight class specified by a letter is also stamped on the casing.

If its replacement is required, and only one connecting rod type as spare part is available, having an intermediate weight class, it can be used to replace any other connecting rod; if connecting rods are still efficient they should not be replaced even if of different class.

Pistons

Figure 9

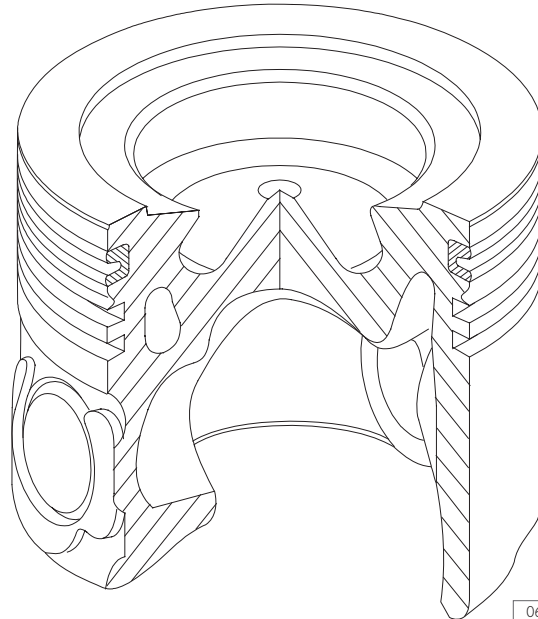

06_089_S

They are part of the high turbulence combustion chamber; annular chambers inside the rim allow the efficient disposal of heat by recirculating the lubrication oil delivered by the nozzles fitted in the engine block.

On the skirt there are three seats for split rings; the 1st one is obtained in a cast iron trapezoidal insert.

Split rings have different functions and different shapes:

- the first seal split ring has trapezoidal shape with ceramic-chrome coating;
- the second seal split ring has rectangular shape and it is of "tapered torsional" type;
- the third ring is fitted with a double oil-scaper pad with inner spring.

The piston crown is engraved with engine type, class and supplier selection, the flywheel symbol showing the assembly direction inside the cylinder liner and the sticker witnessing that the insert adhesion test 1st slot was carried out.

Timing control

Figure 10

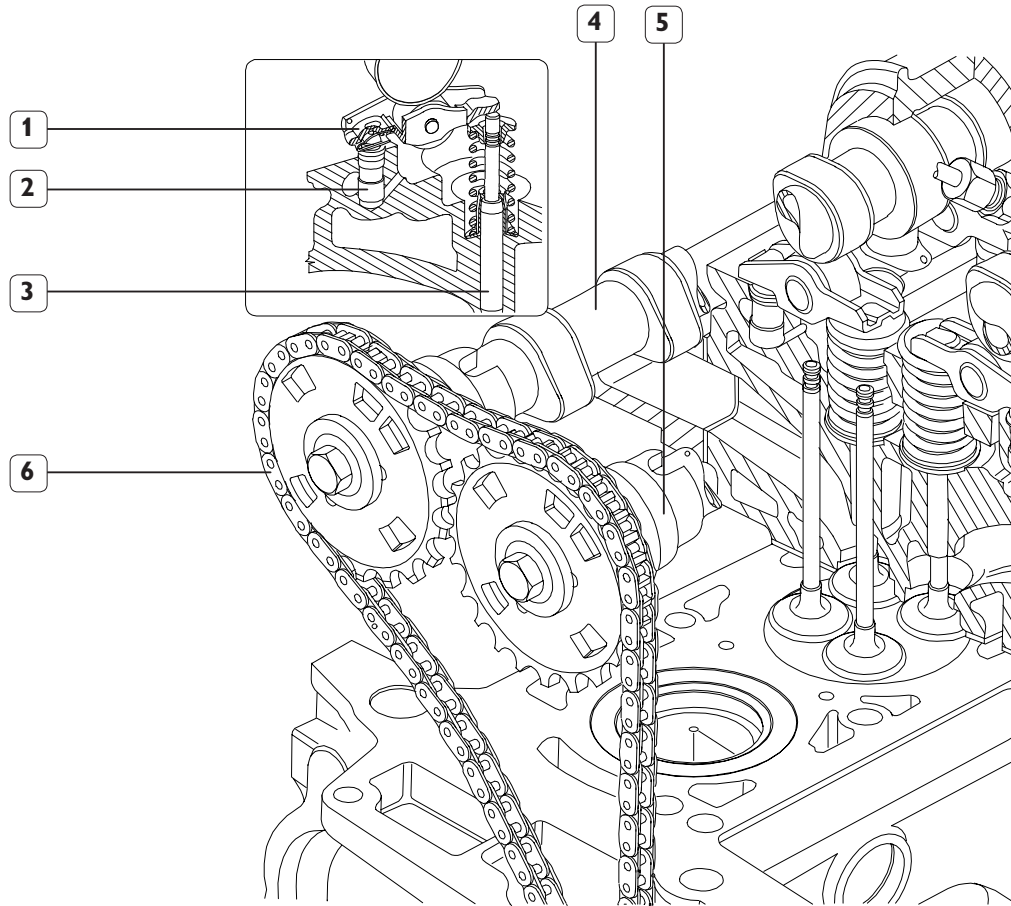

06_013_5

1. Rocker arm - 2. Hydraulic tappet - 3. Valve stem - 4. Exhaust side timing shaft - 5. Intake side timing shaft - 6. Control chain.

Timing is ensured by a double overhead camshaft and four valves per cylinder with hydraulic tappets.

Control is provided by two chains:

- ❑ A double 3/8" chain receiving motion from the driving shaft and transmitting motion to the oil pump and the high pressure pump control shafts;
- ❑ A single chain receiving motion from the high pressure pump control shaft gear and transmitting it to camshafts;

Camshafts control gears are interchangeable; slots are provided to measure phase by the relevant sensor.

Rocker arms, one at a time, are kept in contact with the corresponding cam by an hydraulic tappet; this allows the elimination of periodical adjustments.

Figure 11

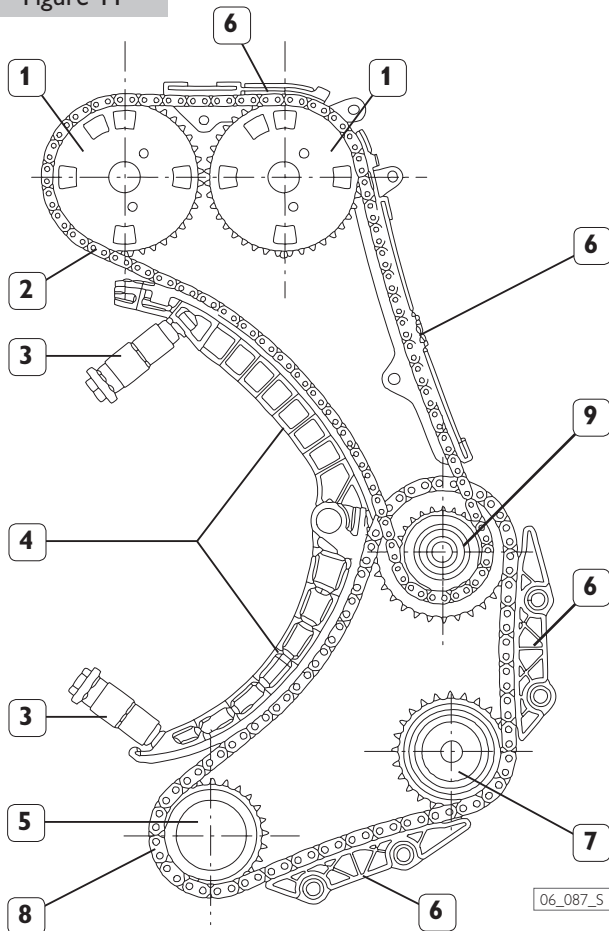

1. Camshafts control gears - 2. Single chain - 3. Hydraulic chain tensioner - 4. Chain tensioner mobile pads - 5. Pilot gear on the driving shaft - 6. Fixed pad - 7. Oil pump control shaft gear - 8. Double chain - 9. High pressure pump control shaft gear.

Cylinder head

Figure 12

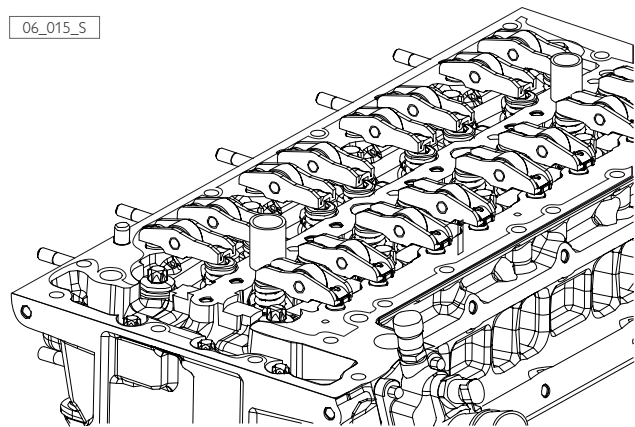

The cylinder head is monolithic and made of cast iron; it is featured by the presence of housings for the following parts:

- Valves with seats featuring inserted elements;
- Electronic injectors;
- Fuel delivery couplings to electronic injectors;
- Intake manifold;
- Exhaust manifold;
- Rocker arms.

Overhead

Figure 13

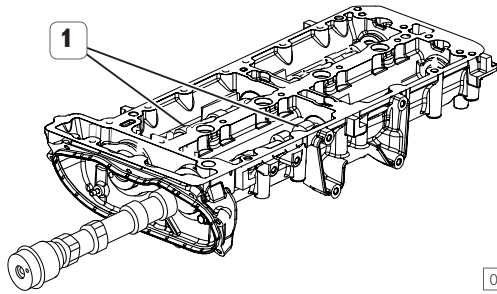

06_091_S

The overhead is fastened to the upper part of the cylinder head, it is made out of aluminium, and it houses (1) the two camshafts for intake and exhaust.

Figure 14

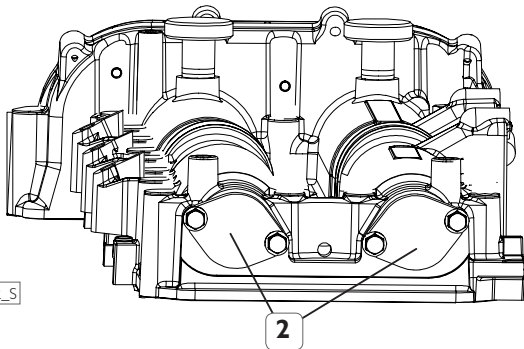

06_092_S

Sealing of the two shafts housed in the overhead is ensured by plates (2).

Figure 15

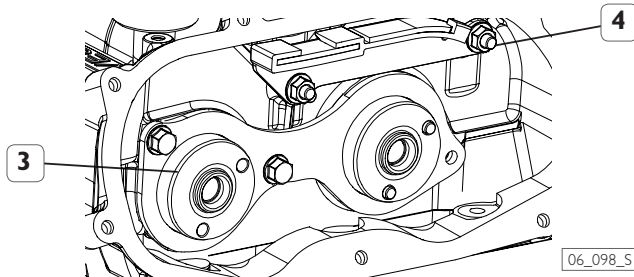

06_098_S

On the opposite side, the shouldering plate (3) and the upper pad (4) complete the positioning of the two camshafts.

Auxiliary gears control

Figure 16

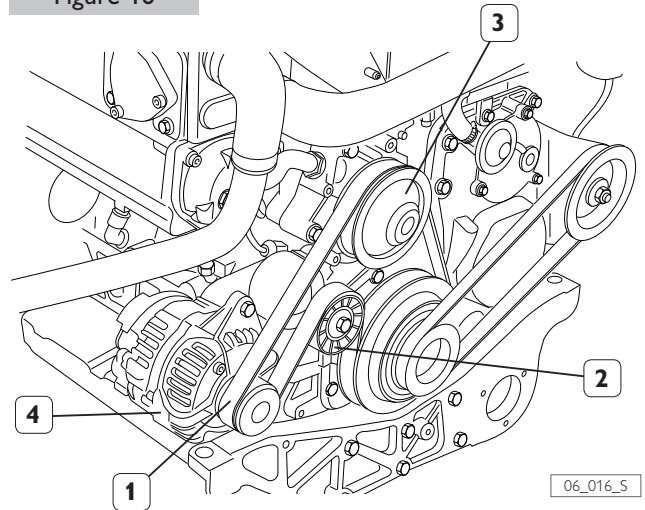

06_016_S

Motion to auxiliary gears is transmitted by a poly-V belt (1) tensioned by an automatic tensioner (2) which actuates the engine coolant pump (3) and the alternator (4).

Figure 17

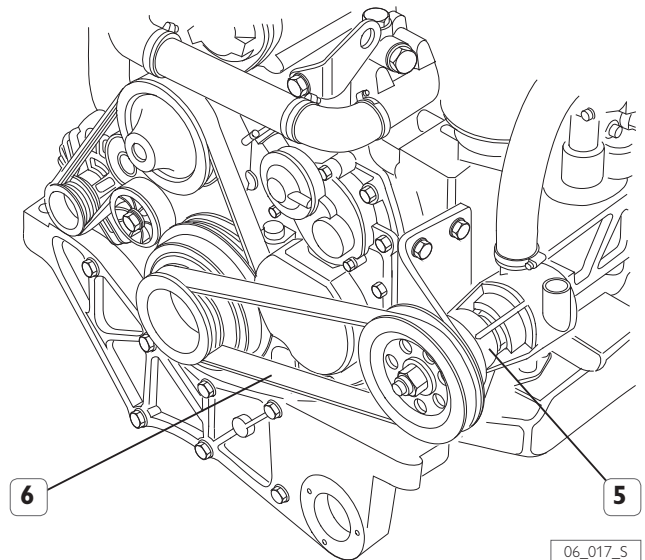

06_017_S

The sea water pump (5) is actuated by the poly-V belt (6) whose replacement must take place every time the component is disassembled.

COMBUSTION AIR INTAKE AND EXHAUST SYSTEM

Figure 18

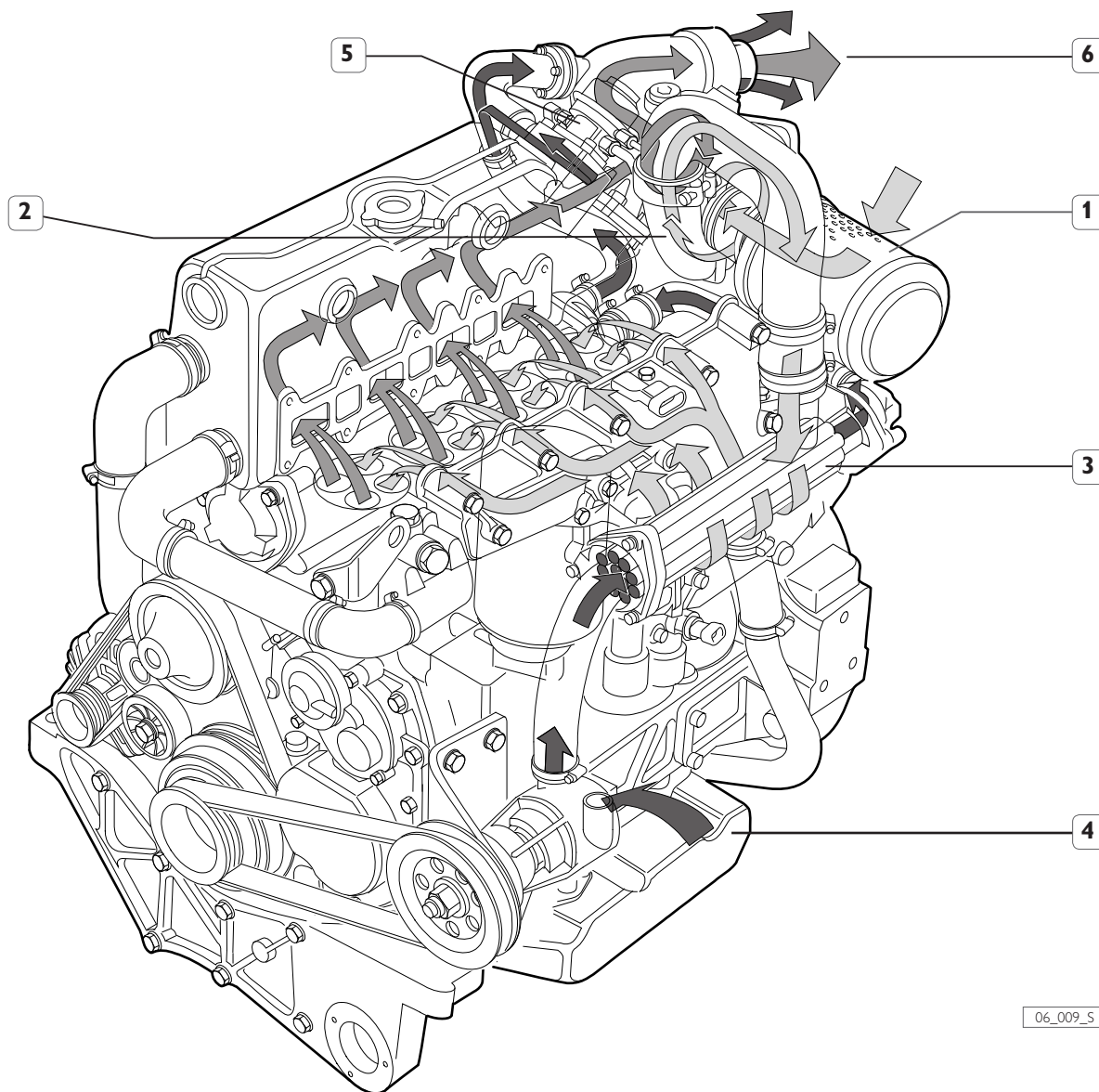

06_009_S

■ Sea water

■ Cold air inlet

■ Exhaust gas

1. Air filter - 2. Turbocompressor - 3. Heat exchanger air/sea-water - 4. Sea water intake -
5. Waste gate valve - 6. Exhaust terminal (riser).

Before reaching the cylinders, supercharging feeding air, intaken through the filter, runs through the heat/sea-water exchanger, thus reducing its temperature, in order to favour a higher engine volumetric efficiency.

The pressure and air temperature sensor located on the induction manifold, provides the ECU of the EDC system with the information enabling a fuel metering adequate to the density of the intaken comburent air and an optimum treatment of the injection advance.

The overboost pressure is controlled by the waste gate valve. According to the air pressure present in the intake manifold,

the opening of the by-pass is operated, conveying exhaust gasses directly to the exhaust system, limiting the turbine-compressor shaft rpms and the consequent overboost degree. The turbocharger rotor and the exhaust manifold are cooled off by the circulation of the engine coolant.

The exhaust gas flows into the exhaust terminal and, where applicable (riser), mixed with sea-water to be expelled.

Comburent air filter

Figure 19

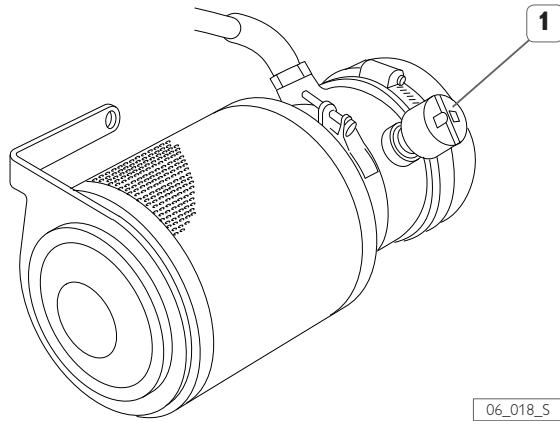

1. Filter clogging sensor.

The combustion air filter is of dry-type, consisting of a filtering cartridge to be replaced on a regular basis. It is provided with a clogging filter as indicating tool.

Turbocompressor

Figure 20

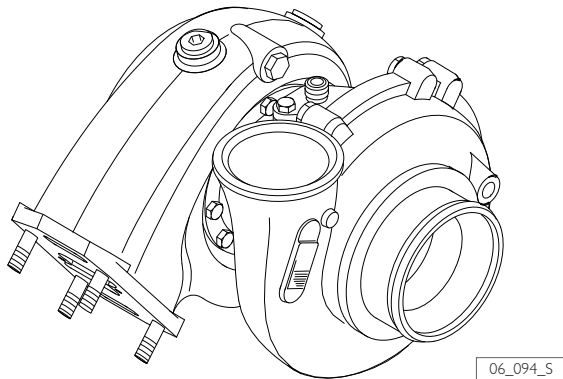

The engine is overboosted by a turbocharger with fixed-geometry turbine whose overboost pressure is controlled by a waste gate valve. The turbocharger group is lubricated by the circulation of the pressurized lubricating oil coming from the overhead, while it is cooled off by the coolant coming from the engine block.

Air/sea-water heat exchanger

Figure 21

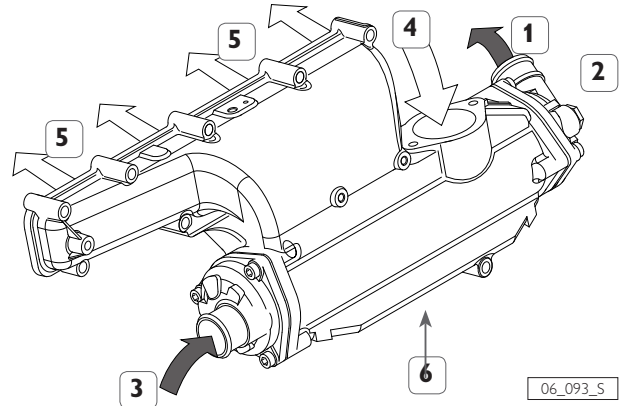

1. Sea-water outlet - 2. Sacrificial anode (Zinc) - 3. Sea-water inlet - 4. Comburent air inlet - 5. Comburent air outlet - 6. Condensate drainage hole.

The flow of water coming from the sea-water pump goes through the tube bundle (3) and, by going through it, absorbs some of the heat of the overheated air of the turbosupercharge, passing through the exchanger coming from the turbocompressor (4).

The outlet water (1) is conveyed towards the fresh water/sea-water heat exchanger, while the turbosupercharged air, cooled down, reaches the induction manifold (5) and from there reaches the cylinders.

Through hole (6) air humidity condensated in water is expelled.

A zinc sacrificial anode is located on the sea water output connection.

COOLING FRESH WATER CLOSED-LOOP

Figure 22

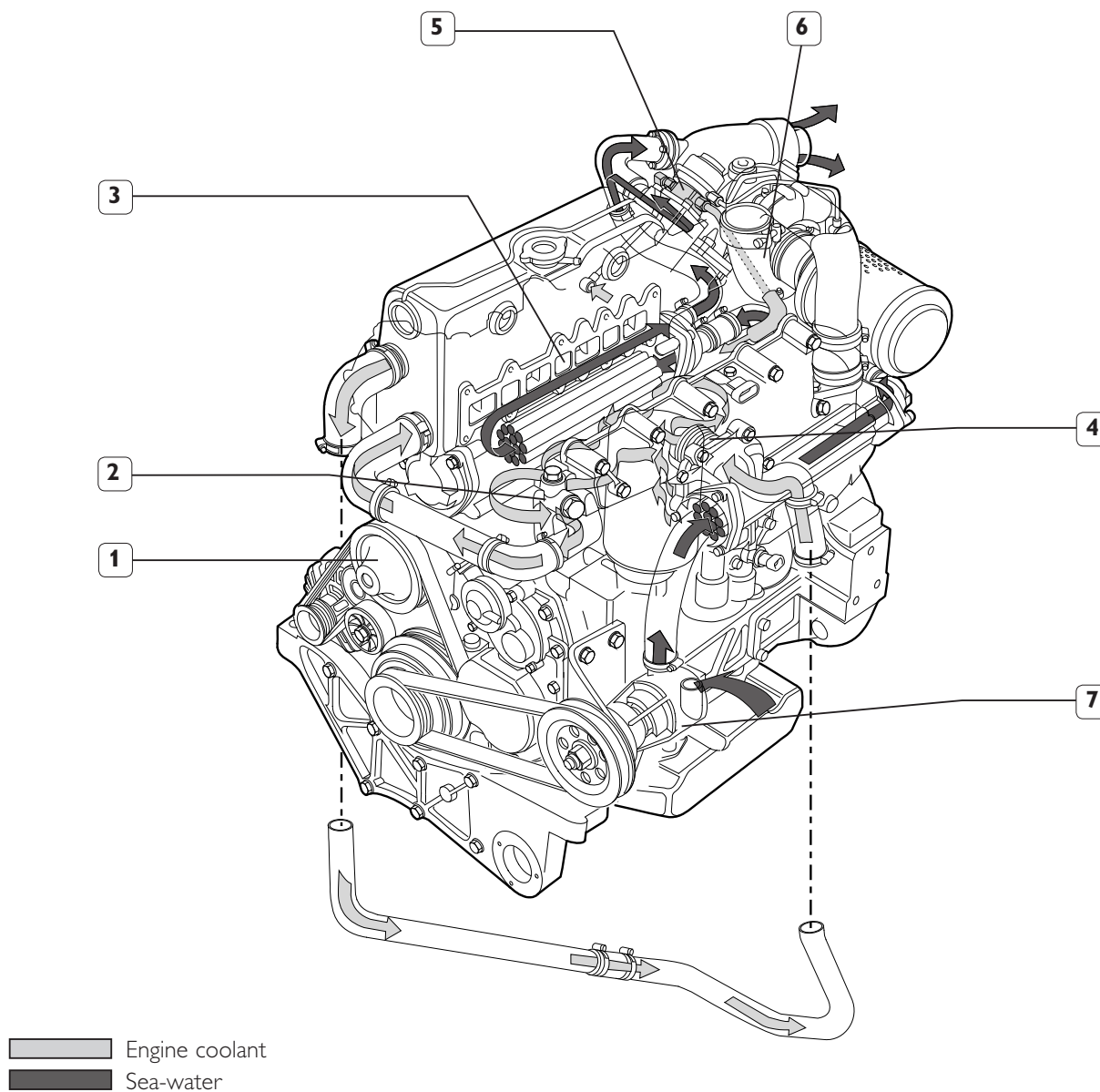

06_008_S

1. Engine coolant pump - 2. Thermostatic valve - 3. Coolant/sea water heat exchanger -
4. Coolant /oil heat exchanger - 5. Waste gate valve - 6. Turbocharger - 7. Sea water pump.

The centrifugal pump (1), actuated by the driving shaft through a poly-V belt, draws the coolant coming from the primary cooling circuit and delivers it to the lubricating oil heat exchanger (4). After the exchanger, the liquid reaches the inside of the engine block in the areas concerned by cylinders' heat exchange. Later on it passes through the thermostatic valve (2) and it is returned to the pump, when the liquid reaches the valve calibrated temperature; if the temperature is exceeded, the coolant is rerouted, proportionally to the achieved temperature, towards the integrated group cooled exhaust manifold- coolant/sea

water heat exchanger (3). From here, a portion of the coolant reaches the turbocharger unit for the waste gate valve cooling (5) and the turbine rotor (6), thus it returns towards the exchanger for cooling off its temperature and then it flows back towards the pump (1).

Coolant pump

Figure 23

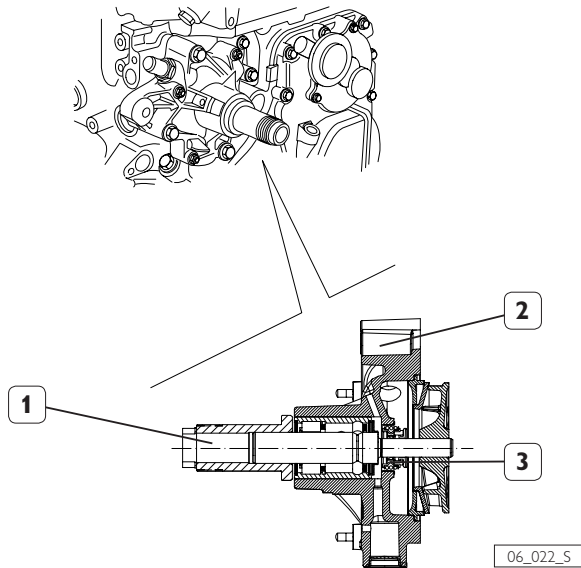

1. Pump shaft - 2. Rotor - 3. Sealing gasket.

The coolant pump is attached to the engine block and it is actuated by a poly-V belt operated by a driving shaft. The coolant is sucked by the pump and conveyed through the heat exchanger of the lubricating oil and thus through the cooling circuit.

The return of the liquid is regulated by a thermostatic valve which deviates the flow directly into the pump or towards the coolant/sea water heat exchanger.

Lubricating oil/engine coolant heat exchanger

Figure 24

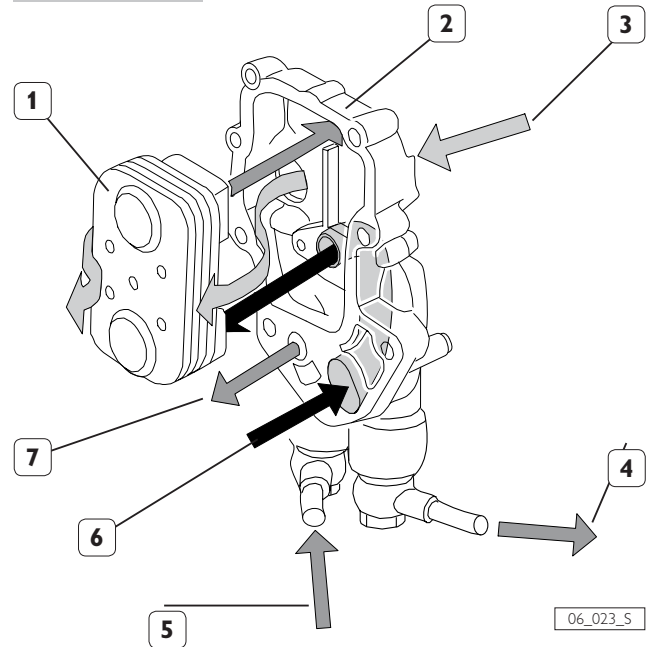

1. Thermal exchange elements - 2. Heat exchanger case - 3. Coolant input - 4. Oil output towards filter - 5. Oil return from the filter - 6. Oil input from the pump - 7. Oil output towards the lubrication circuit.

The lubricating oil heat exchanger is positioned on the LH side, below the air/sea water heat exchanger. It is located between the pump and the oil filter and it consists of five heat exchange elements fitted in a suitable casing which also performs the function of oil flow manifold towards the pump towards the lubrication circuit.

Thank you so much for reading.
Please click the “Buy Now!”
button below to download the
complete manual.



After you pay.

You can download the most
perfect and complete manual in
the world immediately.

Our support email:

ebooklibonline@outlook.com