

VECTOR SERIES

Industrial application

VECTOR 8

Technical and Repair manual

CORRESPONDENCE BETWEEN TECHNICAL CODE AND COMMERCIAL CODE

Technical Code	Open Commercial Code
FVAE2885X*F100	VECTOR 8 TE2
FVAE2884A*B20I	-
FVAE2884A*B200	-
FVKE2887A*A200	-

LUBRICATION

The forced feed lubrication is produced by the following components:

- oil pump with rotors, housed in the rear part of the crankcase inside the sump.
It is driven by a helical toothed gear fitted on the crankshaft. The pump casing contains an oil pressure regulation valve.
- water/oil heat exchanger.
- oil filter mounting equipped with:
 - oil pressure regulation valve;
 - by-pass valve for excluding blocked oil filter;
 - cartridge oil filter.

OPERATING PRINCIPLE

The (forced type) lubrication of the engine is produced by means of an oil pump fastened to the rear part of the crankcase and driven by the crankshaft through an intermediate gear.

This pump draws in oil from the sump and sends it to the water/oil heat exchanger, to the filter assembly and, later on, to the oil distribution ducts in the crankcase; the pressure of the oil is controlled by the pressure valve at the filter inlet.

The oil heat exchanger is the type with flat pipes that comes into contact with the coolant.

The oil is directed, from the two oil distribution ducts, positioned lengthwise in the crankcase, to lubricate the crankshaft bearings and the camshaft and to cool the piston through calibrated jets.

Other ducts direct the oil to each of the heads to lubricate the timing components.

The oil flow rate is managed by two pressure relief valves (4) (one per bank) which close when the oil pressure reaches minimum values (engine idling) in order to protect the bearings and other engine components.

The components fitted in the front and rear sections of the engine are lubricated by oil sprayed by special jets .

The crankshafts for the turbines are suitably lubricated by two pipes coming from the crankcase and the drainage goes directly to the sump.

The return oil from the various components is collected in the oil sump.

The oil is filtered by means of two cartridge filters with a paper filter element operating in series.

The opening pressure of the oil filter safety valve is 3.4 ± 0.3 bar.

The theoretical starting temperature pressure for the engine lubrication pressure regulation valve (5) is around 5 bar.

The opening pressure for the piston lubrication pressure regulation valves (4) is around 2.65 bar.

Figure 3

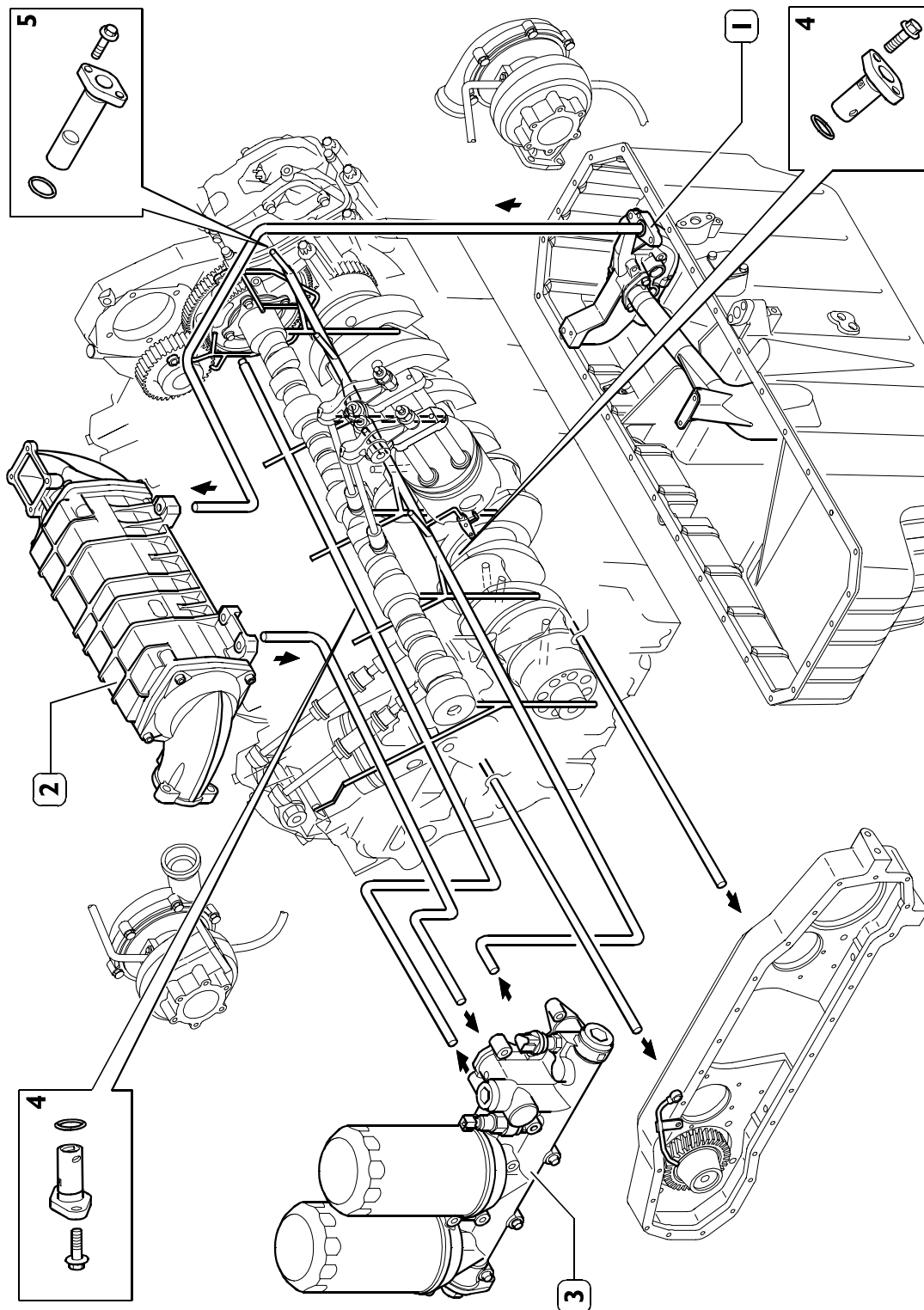

1. Oil pump - 2. Water/oil heat exchange - 3. Oil filter support - 4. Relief pressure valve (piston cooler) - 5. Relief pressure valve (Engine oil pressure system).

103278

Oil vapour recirculation - blow-by filter

The oil vapours produced by the lubrication of the moving parts are directed via the pipe (3) and then are collected and filtered in the blow - by (1).

In the blow-by, some of the vapours condense and return to the oil sump via the pipe (2), whilst the remaining vapours are recirculated in the intake.

Figure 4

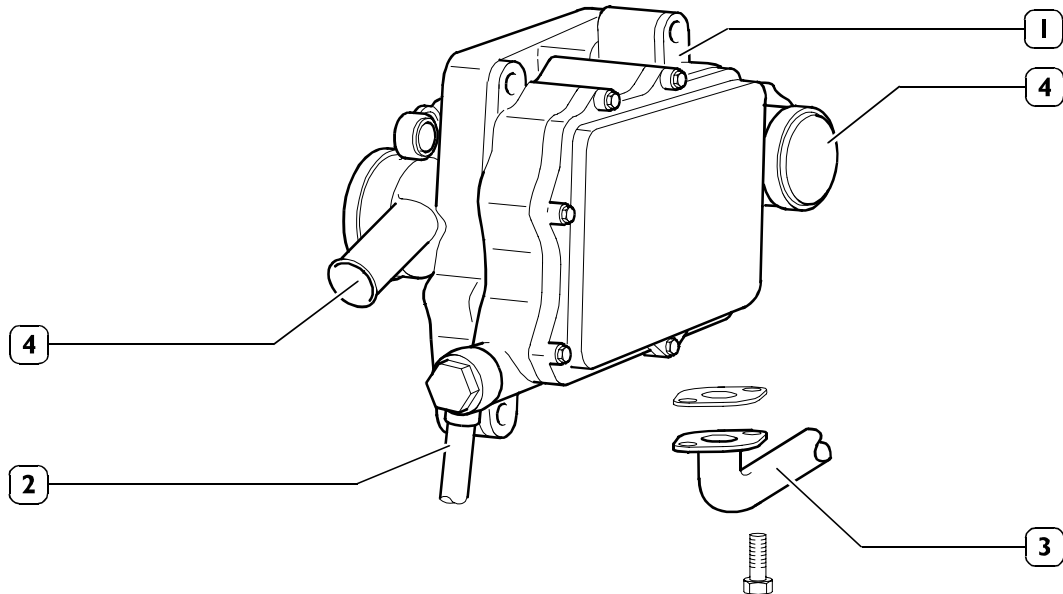

103275

1. Blow-by filter - 2. Sump drainage pipe - 3. Oil vapour inlet - 4. Gas outlet

Figure 5

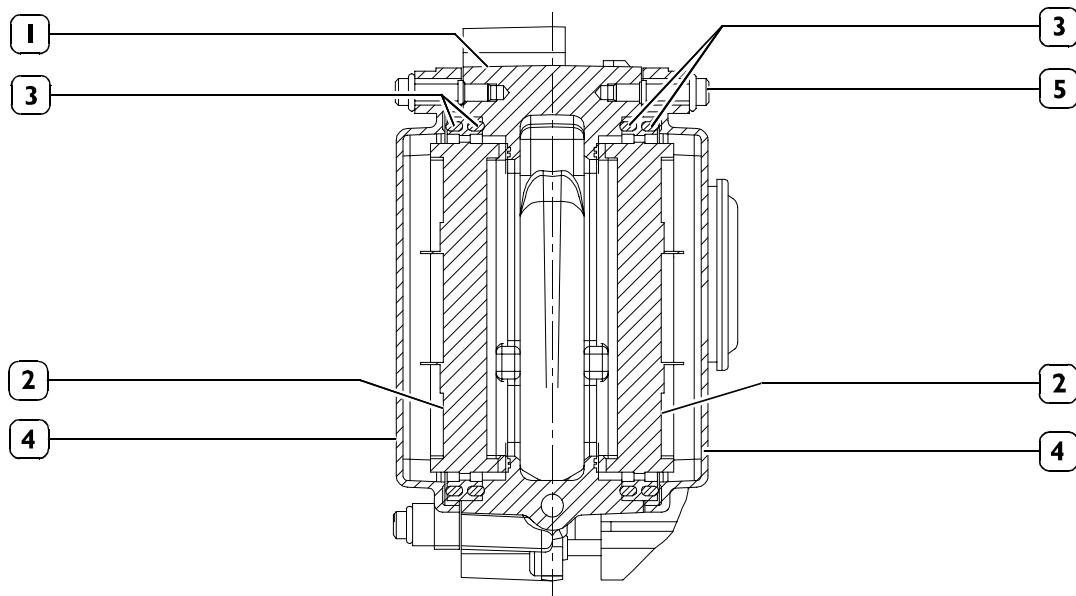

81366

1. Blow-by filter casing - 2. Filter - 3. Gasket - 4. Cover - 5. Cover fixing bolts

The blow-by comprises two filtering layers (2), a casing (1) and two gaskets (3) which ensure the seal between the casing and the two covers (4).

ENGINE COOLING

The cooling system is responsible for cooling the engine casing and the engine lubrication oil inside the heat exchanger (2).

From the circulation pump (1), the coolant is sent to the heat exchanger (2) where the engine lubrication oil is cooled. From here the coolant reaches the engine block and, after having cooled the cylinders, is sent to the thermostat casing.

Depending on the temperature, the coolant is either recirculated by the water pump (1) or sent to the radiator.

Figure 6

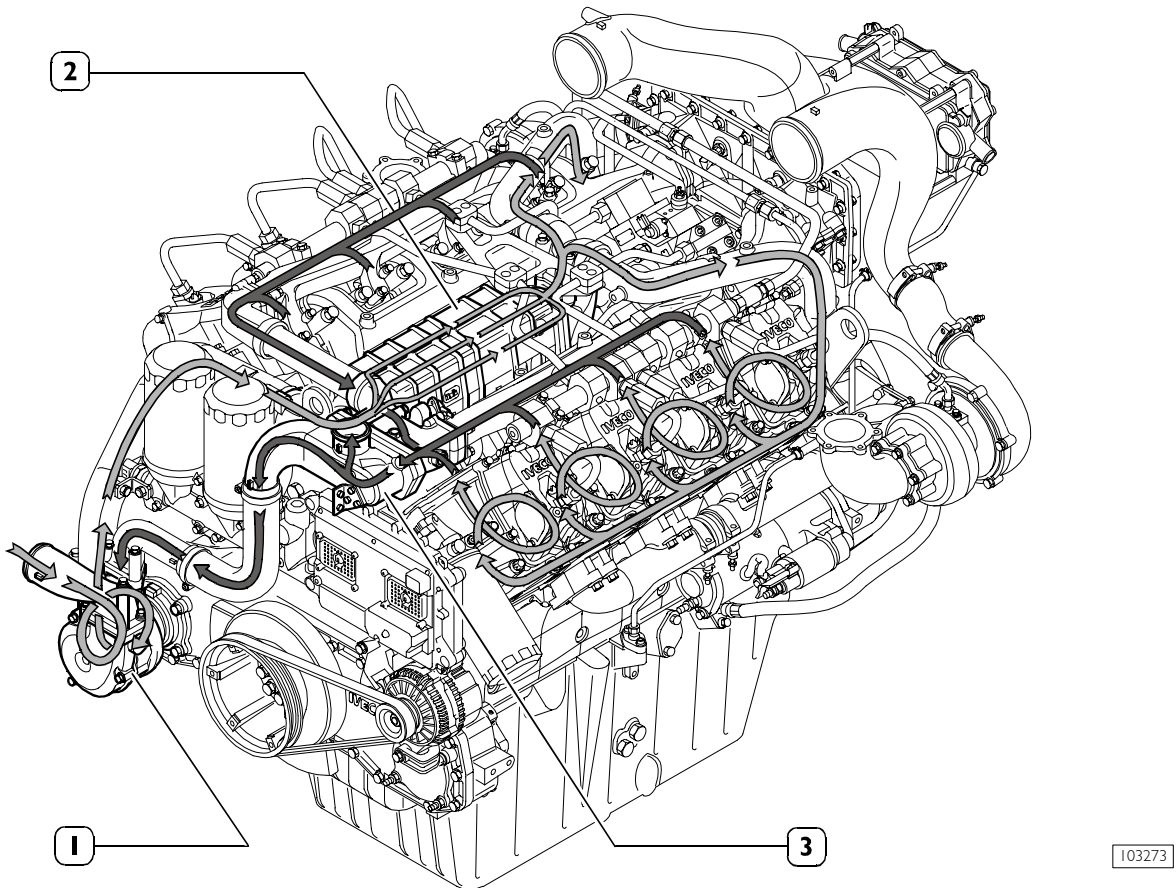

1. Circulation pump - 2. Engine lubrication water/oil heat exchanger - 3. Thermostat casing

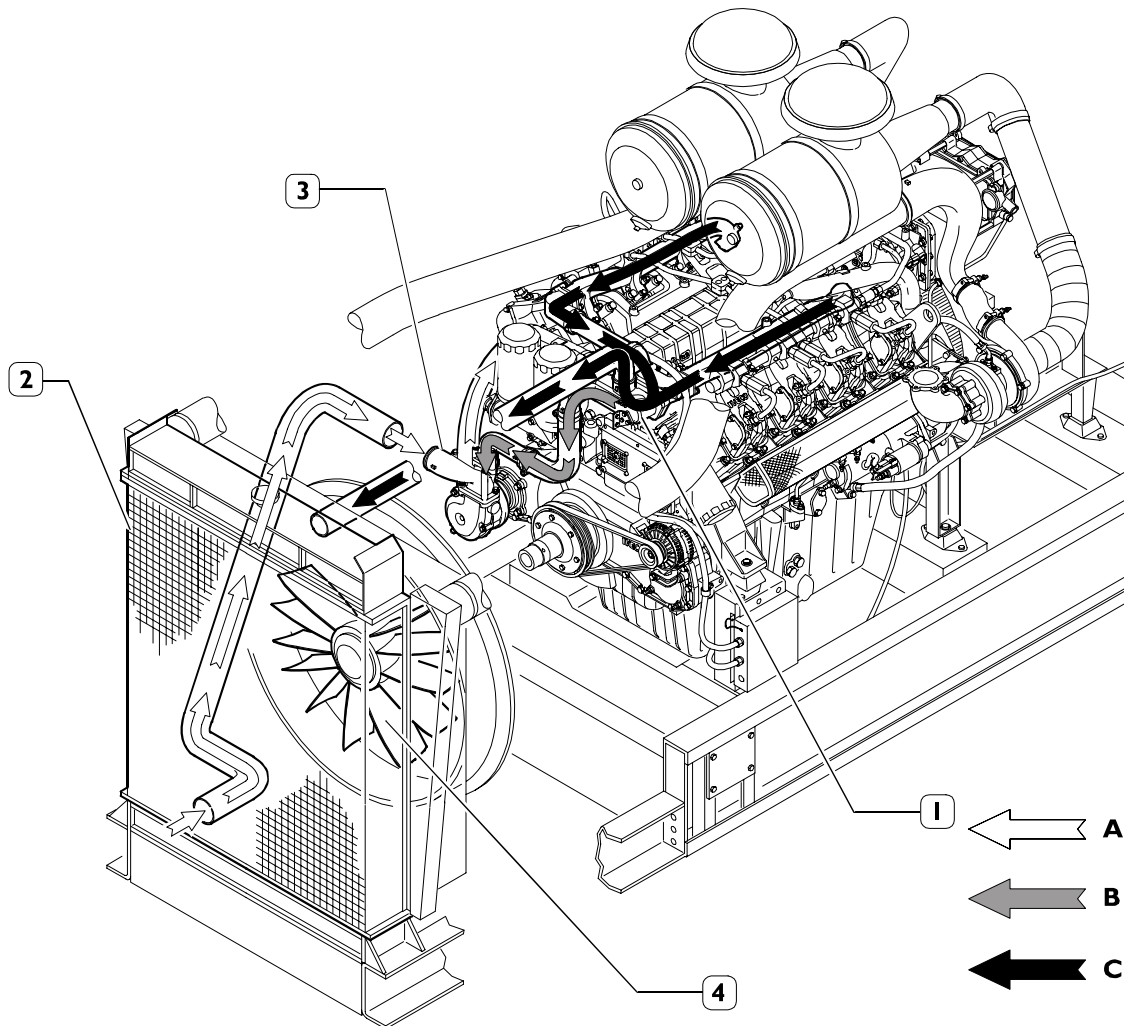
COOLING SYSTEM ASSEMBLY**Figure 7**

112492

1. Thermostat casing - 2. Radiator - 3. Coolant circulation pump - 4. Cooling fan.

A

Coolant coming from the cooling radiator being drawn into the pump.

B

Coolant coming from the engine block passing through the thermostat casing (temperature < 70°C) sent to the circulation pump.

C

Coolant coming from the engine block passing through the thermostat casing (thermostat valve opening temperature around 70°C, complete travel 85°C) to the cooling radiator.

VARIANT FOR APPLICATIONS WITH BRAKE AIR COMPRESSOR

Figure 8

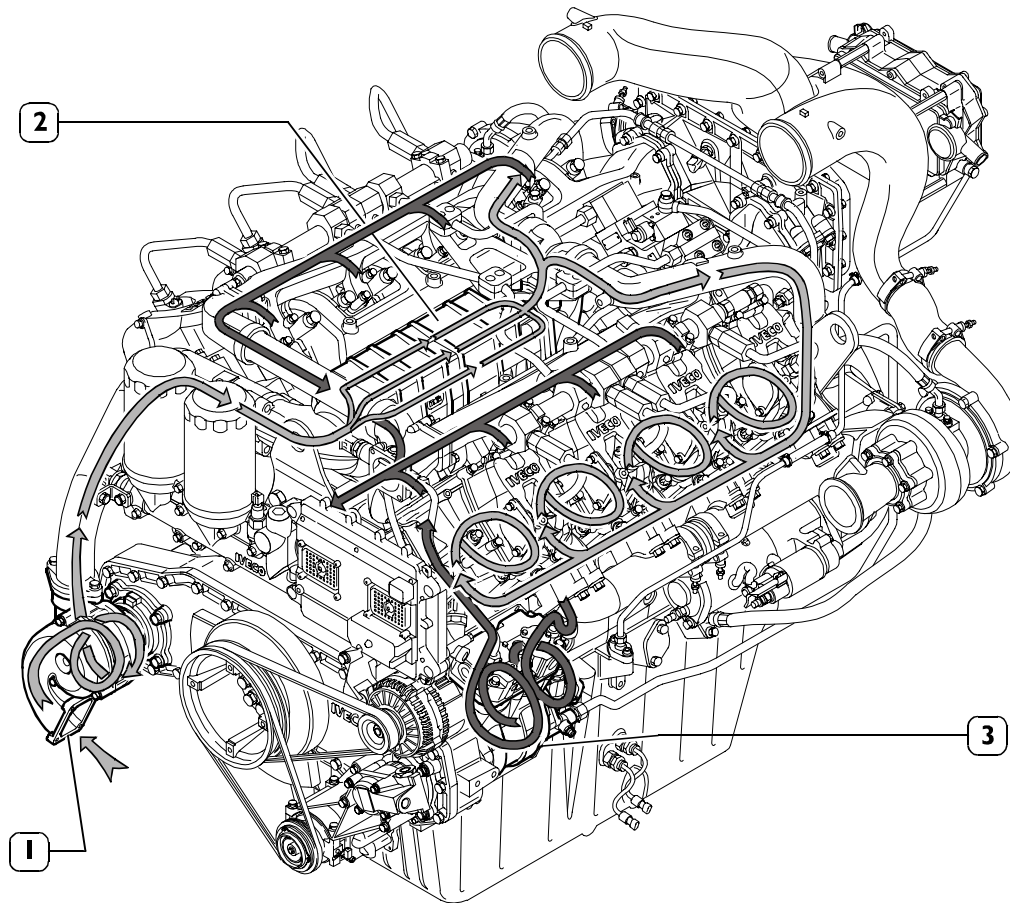

103509

Rif.	Description
1	Circulation pump
2	Engine lubrication water/oil heat exchanger
3	Air system compressor (for DRAGON applications)

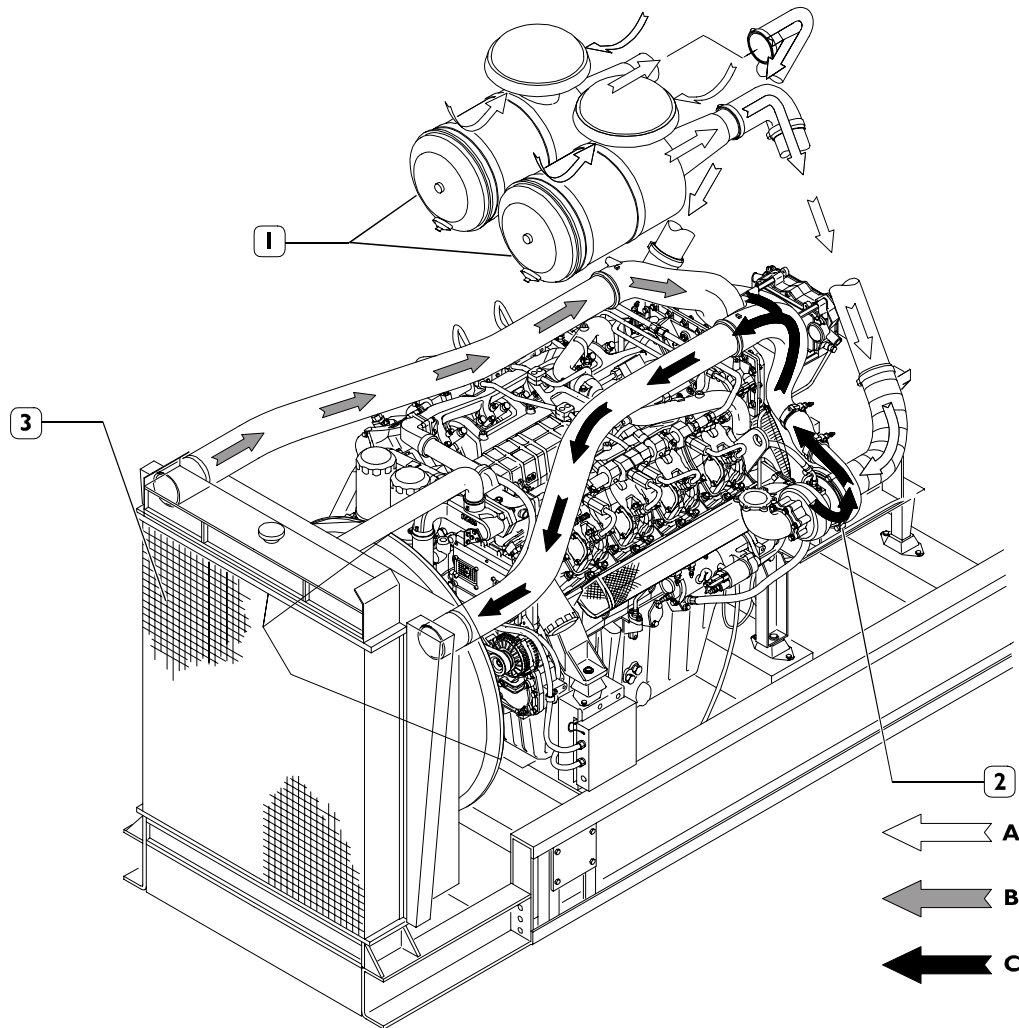
AIR/AIR INTERCOOLER SYSTEM (DRAGON, G-DRIVE AND GRIFFON APPLICATIONS)**Figure 9**

112484

1. Air filter - 2. Turbochargers - 3. Heat exchanger (air/air intercooler)

A

Air drawn in by the filters and sent to the turbochargers.

B

Air drawn in from the heat exchanger (air/air intercooler) to the main intake manifold and from there to the bank intake manifolds.

C

Hot supercharging air coming from the two turbines to the heat exchanger (air/air intercooler).

The system has been designed to lower the temperature of the supercharging air before it is sent to the cylinders.

The air is drawn in and filtered by means of two dry filters and introduced inside the turbochargers.

The air is compressed, with a consequent increase in temperature and, after having been collected in a single pipe, it is sent to the intercooler.

This heat exchanger, which the flow of air produced by the fan fastened axially and driven by the crankshaft comes into contact with, cools the compressed air and sends it, via the pipe, to the main manifold and from there to the two intake manifolds, located on each bank.

On versions for cold climates, there are two pre-heating heaters on the main manifold designed to assist engine starting at low temperatures (ambient temperature up to -25°C).

Heater voltage: 24V DC

Peak current: $240 \pm 50^{\circ}$

Stabilization current: $83 \pm 12\text{A}$.

Together with the above mentioned heaters, these versions also have a resistance for heating the engine lubrication oil and a fuel heater on the diesel pre-filter.

AIR / WATER INTERCOOLER SYSTEM (SPRINKLER APPLICATIONS)

Figure 10

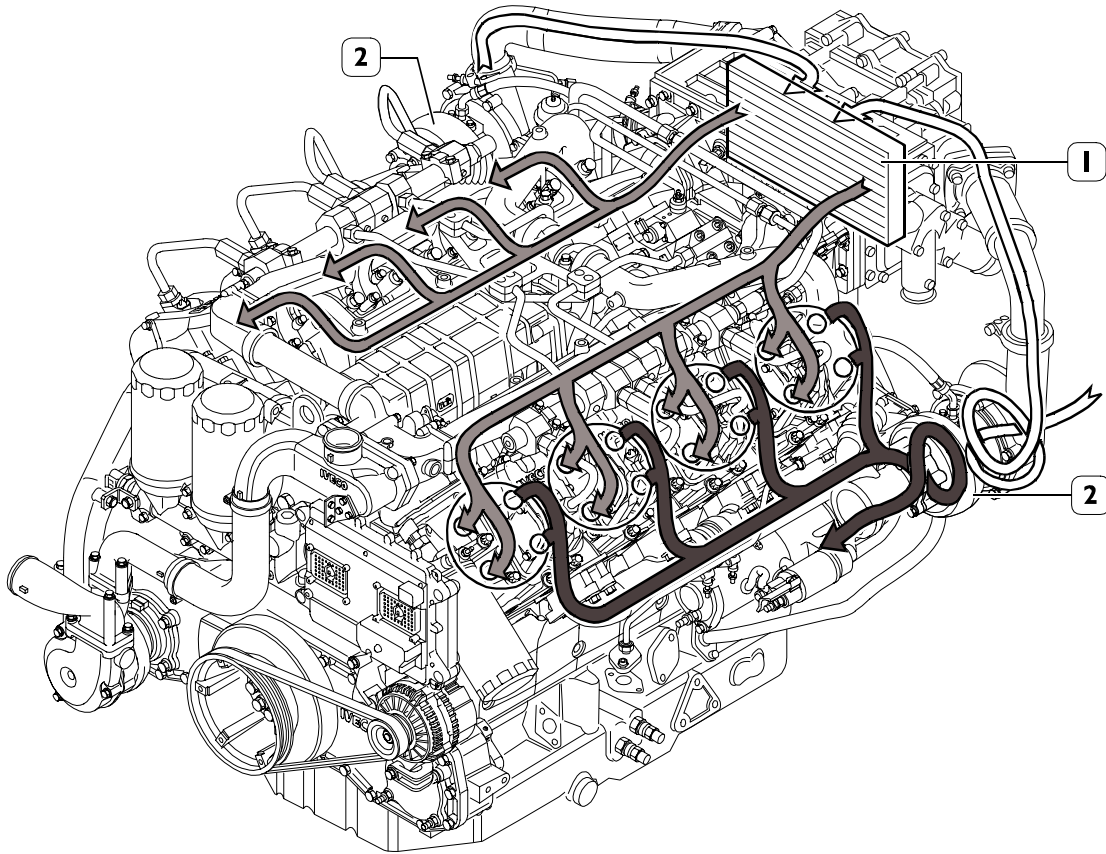

112488

- Intake air and hot compressed air
- Cold compressed air
- Exhaust

1. Heat exchanger (air/water intercooler) - 2. Turbochargers

SUPERCHARGING

The exhaust fumes are directed to the turbocharger (1) which rotates the section which draws in the air from the filters and compresses it (with a consequent increase in temperature).

The hot compressed air is directed to the inside of the heat exchanger (air/air intercooler) in which it is cooled and sent to the intake manifolds and to the inlet valves.

Figure 11

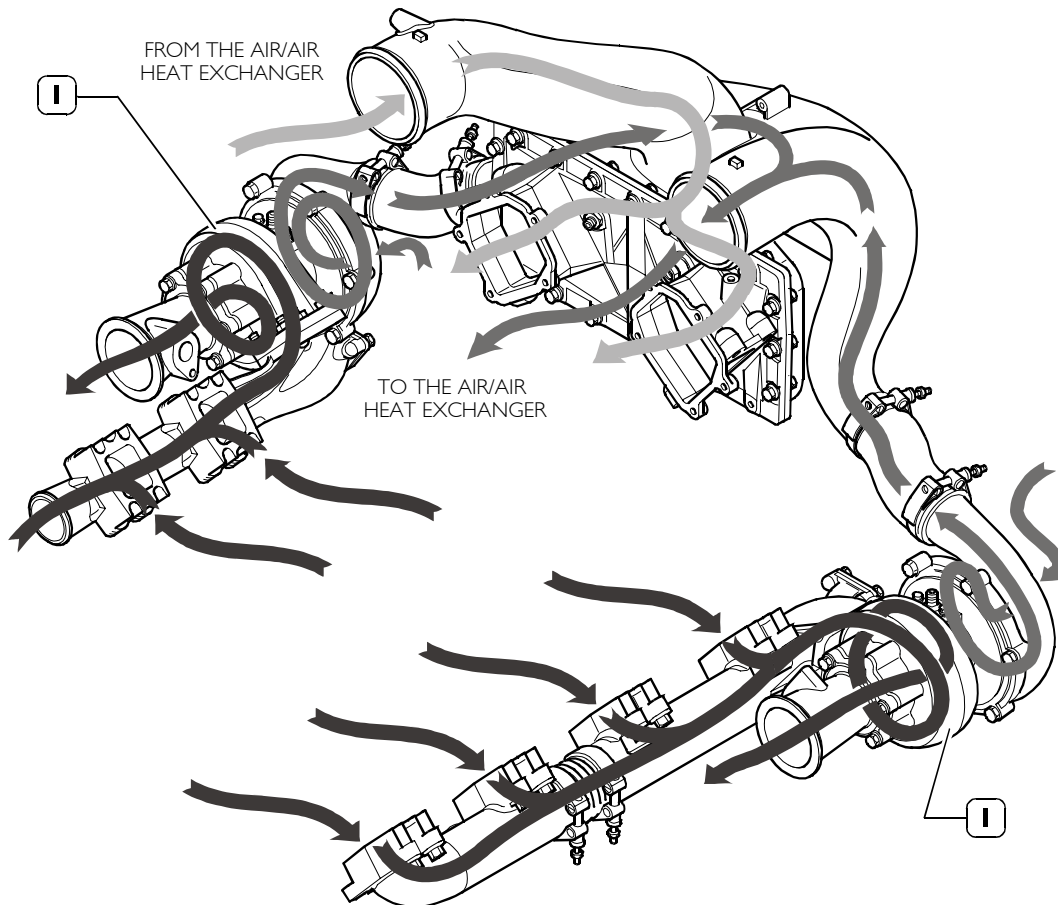

103512

Thank you so much for reading.
Please click the “Buy Now!”
button below to download the
complete manual.



After you pay.

You can download the most
perfect and complete manual in
the world immediately.

Our support email:

ebooklibonline@outlook.com