

PART NO. EM18P-1-1

HITACHI

Operator's Manual

EX8000-6

Hydraulic Excavator

Serial No 000104 and up

INDEX

MACHINE NUMBERS

SAFETY

SAFETY SIGNS

COMPONENTS NAME

HANDLING STAIRWAY/EMERGENCY ROPE

OPERATOR'S STATION

BREAK-IN

OPERATING THE ENGINE

DRIVING THE MACHINE

OPERATING THE MACHINE

MAINTENANCE

MAINTENANCE UNDER SPECIAL ENVIRONMENTAL CONDITIONS

STORAGE

TROUBLESHOOTING

SPECIFICATIONS

INDEX

MACHINE NUMBERS

MACHINE TYPE AND SERIAL NUMBER

TYPE: _____

MFG. NO.: _____

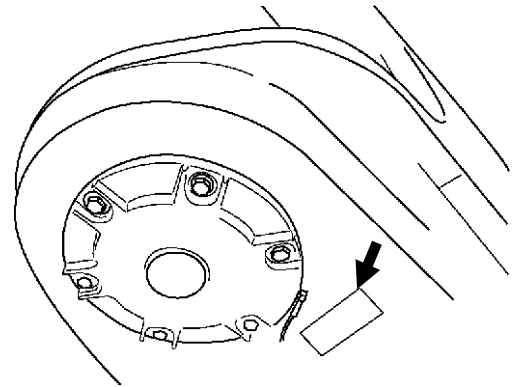

PRODUCT IDENTIFICATION NUMBER

PRODUCT IDENTIFICATION NUMBER: _____

NOTE:

_____ Marks to indicate the start and end of the PIN
HCM18P00P00000101

PRODUCT IDENTIFICATION NUMBER (PIN)

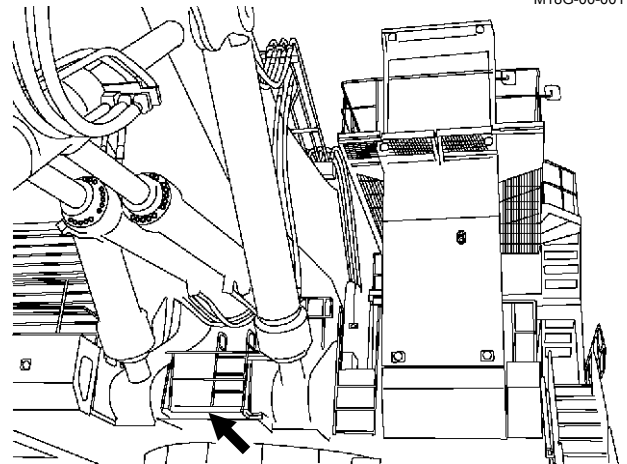

M18G-00-001

M18G-01-041

ENGINE TYPE AND SERIAL NUMBER

TYPE: _____

MFG. NO.(LEFT) : _____

MFG. NO.(RIGHT) : _____

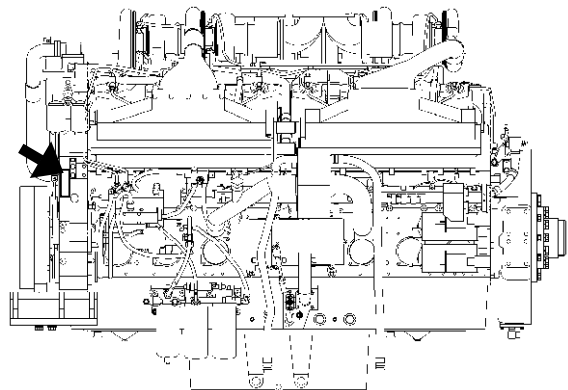

TRAVEL MOTOR TYPE AND SERIAL NUMBER

TYPE: _____

MFG. NO.(LEFT FRONT) : _____

MFG. NO.(LEFT REAR) : _____

MFG. NO.(RIGHT FRONT) : _____

MFG. NO.(RIGHT REAR) : _____

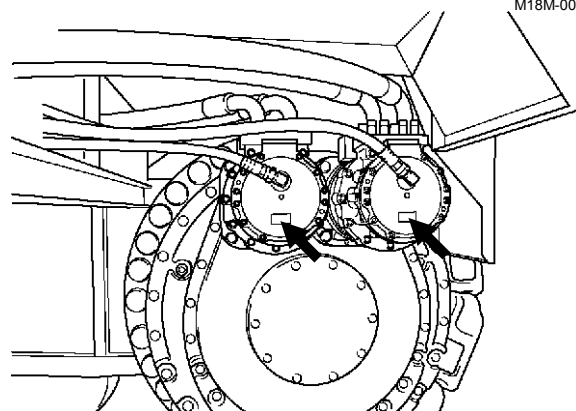

M18M-00-002

M18G-07-065

MACHINE NUMBERS

SWING MOTOR TYPE AND SERIAL NUMBER

TYPE: _____
MFG. NO.(FRONT LEFT) : _____
MFG. NO.(FRONT CENTER): _____
MFG. NO.(FRONT RIGHT): _____
MFG. NO.(REAR LEFT): _____
MFG. NO.(REAR CENTER) : _____
MFG. NO.(REAR RIGHT): _____

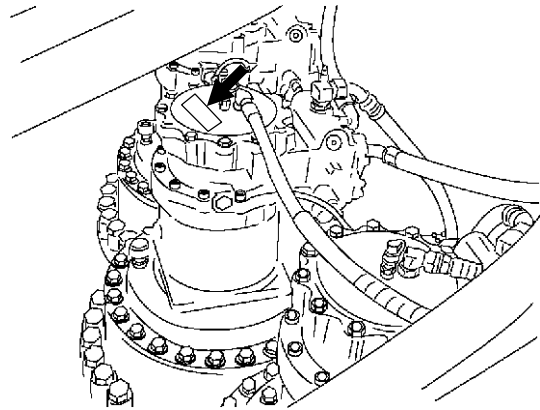

M18G-07-063

HYDRAULIC PUMP TYPE AND SERIAL NUMBER

TYPE: _____
MFG. NO.(LEFT 1, 2): _____
MFG. NO.(LEFT 3, 4): _____
MFG. NO.(LEFT 5, 6): _____
MFG. NO.(LEFT 7, 8): _____
MFG. NO.(RIGHT 9, 10): _____
MFG. NO.(RIGHT 11, 12): _____
MFG. NO.(RIGHT 13, 14): _____
MFG. NO.(RIGHT 15, 16): _____

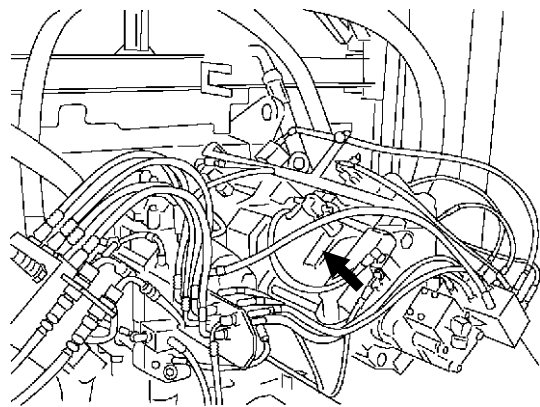

M18G-00-002

FRONT TYPE AND SERIAL NUMBER (LOADING SHOVEL)

TYPE: _____
MFG. NO.: _____

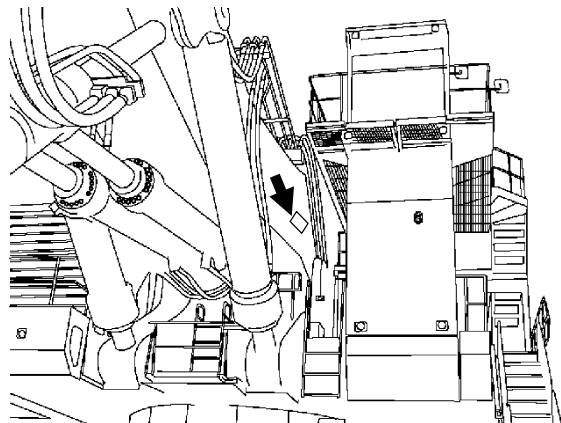

M18G-01-041

BUCKET TYPE AND SERIAL NUMBER (LOADING SHOVEL)

TYPE: _____
MFG. NO.: _____

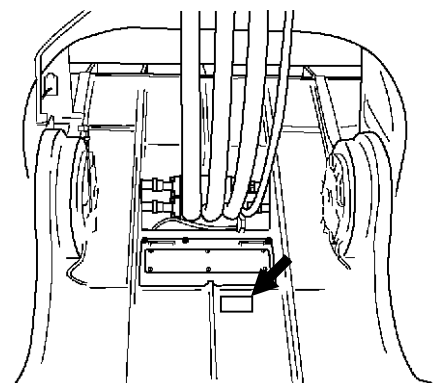

M18G-07-049

MACHINE NUMBERS

CONTROL VALVE TYPE AND SERIAL NUMBER

TYPE: _____

MFG. NO.(UPPER LEFT): _____

MFG. NO.(UPPER CENTER): _____

MFG. NO.(UPPER RIGHT): _____

MFG. NO.(LOWER LEFT): _____

MFG. NO.(LOWER CENTER): _____

MFG. NO.(LOWER RIGHT): _____

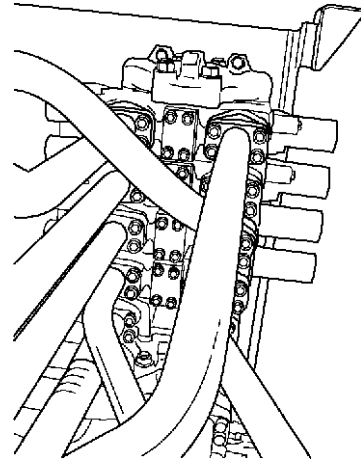

M18G-07-093

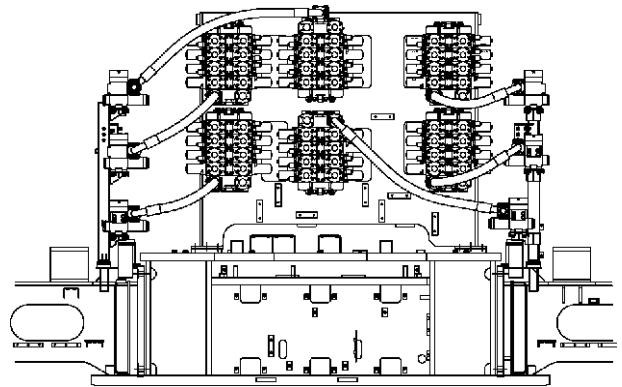

M18G-00-003

CONTENTS

MACHINE NUMBERS

SAFETY

Recognize Safety Information.....	S-1
Understand Signal Words.....	S-1
Follow Safety Instructions.....	S-2
Prepare for Emergencies.....	S-2
Wear Protective Clothing.....	S-3
Protect Against Noise.....	S-3
Inspect Machine.....	S-3
General Precautions for Cab.....	S-4
Use Handholds and Steps.....	S-5
Adjust the Operator's Seat.....	S-5
Ensure Safety Before Rising from or Leaving Operator's Seat.....	S-5
Fasten Your Seat Belt.....	S-6
Move and Operate Machine Safely.....	S-6
Handle Starting Aids Safely.....	S-6
Operate Only from Operator's Seat.....	S-7
Jump Starting.....	S-7
Keep Riders Off Machine.....	S-7
Precautions for Operations.....	S-8
Investigate Job Site Beforehand.....	S-9
Protect Against Falling Stones and Debris.....	S-10
Provide Signals for Jobs Involving Multiple Numbers of Machines.....	S-10
Confirm Direction of Machine To Be Driven.....	S-10
Drive Machine Safely.....	S-11
Avoid Injury from Rollaway Accidents.....	S-13
Avoid Injury from Back-Over and Swing Accidents.....	S-14
Keep Person Clear from Working Area.....	S-15
Never Position Bucket Over Anyone.....	S-15
Avoid Undercutting.....	S-15
Avoid Tipping.....	S-16
Never Undercut A High Bank.....	S-16
Dig With Caution.....	S-17
Operate With Caution.....	S-17
Avoid Power Lines.....	S-17
Precautions for lightning.....	S-18
Object Handling.....	S-18
Protect Against Flying Debris.....	S-18
Park Machine Safely.....	S-19
Handle Fluids Safely—Avoid Fires.....	S-19
Practice Safe Maintenance.....	S-20
Warn Others of Service Work.....	S-21
Support Machine Properly.....	S-21
Stay Clear of Moving Parts.....	S-21
Prevent Parts from Flying.....	S-22
Store Attachments Safely.....	S-22
Prevent Burns.....	S-23
Replace Rubber Hoses Periodically.....	S-23
Avoid High-Pressure Fluids.....	S-24
Prevent Fires.....	S-25
Evacuating In Case of Fire.....	S-26
Beware of Exhaust Fumes.....	S-26

Precautions for Welding and Grinding.....	S-27
Avoid Heating Near Pressurized Fluid Lines.....	S-27
Avoid Applying Heat To Lines Containing Flammable Fluids.....	S-27
Remove Paint Before Welding or Heating.....	S-28
Beware of Asbestos Dust.....	S-28
Prevent Battery Explosions.....	S-29
Service Air Conditioning System Safely.....	S-29
Handle Chemical Products Safely.....	S-30
Dispose of Waste Properly.....	S-30

SAFETY SIGNS.....	S-31
--------------------------	-------------

COMPONENTS NAME.....	1-1
-----------------------------	------------

HANDLING STAIRWAY / EMERGENCY ROPE

Using Stairway.....	1-2
Operating Stairway.....	1-2
Emergency Escape.....	1-5
Emergency Exit.....	1-6
Evacuating In Case of Fire.....	1-7

OPERATOR'S STATION

Cab Features.....	1-9
Monitor Display.....	1-10
Starting Check Screen.....	1-10
Meter Check Screen.....	1-11
Tachometer.....	1-12
Coolant Temperature Gauge.....	1-12
Hydraulic Oil Temperature Gauge.....	1-12
Fuel Gauge.....	1-12
Engine Oil Pressure Gauge.....	1-13
Engine Oil Temperature Gauge.....	1-13
Hour Meter.....	1-13
Warning Indicators.....	1-13
Alternator Indicator.....	1-13
Pump Transmission Oil Level Indicator.....	1-14
Engine Stop Indicator.....	1-14
Engine Oil Pressure Indicator.....	1-14
Coolant Overheat Indicator.....	1-14
Coolant Level Indicator.....	1-15
Engine Over Run Indicator.....	1-15
Fuel Temperature Indicator.....	1-15
Hydraulic Oil Level Indicator.....	1-15
Stop Valve Indicator.....	1-16
Auto-Lubrication Indicator.....	1-16
Fast-Filling Indicator.....	1-17
Emergency Engine Stop Indicator.....	1-17
Tension Indicator.....	1-17
Electric Lever Indicator.....	1-17
Caution Indicators.....	1-18
Exhaust Temperature Indicator.....	1-18
Engine Warning Indicator.....	1-18
Hydraulic Oil Overheat Indicator.....	1-18
Pump Contamination Indicator.....	1-18
Stairway Position Indicator.....	1-19

CONTENTS

Air Cleaner Restriction Indicator	1-19
Electrical Equipment Box Indicator	1-19
Status Indicators	1-19
Auto-Idle Indicator	1-19
Travel Mode Indicator	1-20
Prelub Indicator	1-20
Left Console	1-21
Warning Lamp	1-21
Caution Lamp	1-21
Key Pad	1-21
Monitor Contrast Switch	1-21
Wiper Switch	1-22
Washer Switch	1-22
Wiper Delay Selector Switch	1-22
Air Conditioners	1-23
Designations and Functions of Controls	1-24
Cooling	1-26
Heating	1-26
Dehumidifying and Heating (To Prevent the Windshield from Clouding	1-26
Defrosting	1-27
Blower Operation Without Cooling or Heating	1-27
Ventilation the Cab	1-27
FM/AM Radio Operation	1-28
Digital Clock Setting Procedure	1-29
Right Console	1-30
Key Switch	1-30
Emergency Engine Stop Switch	1-30
Engine Start Switch	1-31
Engine Stop Switch	1-31
Engine Speed Control Dial	1-32
Work Light Switch	1-33
Dome Light Switch	1-34
Maintenance Light Switch	1-35
Entrance Light Switch	1-36
Travel Mode Switch	1-37
Auto-Idle Switch	1-37
Buzzer Stop Switch	1-38
Fast-Filling System	1-39
Rear Console	1-40
Horn Switch	1-41
Adjusting the Seat	1-42
Seat Belt	1-45
Cab Door Release Button	1-46
Opening Cab Left Window	1-46

BREAK-IN

Observe Machine Closely	2-1
Every 10 Hours or Each Shift	2-1
After the First 50 Hours	2-2

OPERATING THE ENGINE

Inspect Machine Daily Before Starting	3-1
Before Turning Power On	3-3
Turning Power On	3-4

Starting the Engine	3-9
Starting In Cold Weather	3-10
Check Instruments After Starting	3-11
Using Booster Batteries	3-12
Stopping the Engine	3-14
Emergency Engine Stop Switch	3-15
Engine Stop Switches	3-16

DRIVING THE MACHINE

Drive the Machine Carefully	4-1
Steering the Machine Using Pedals	4-2
Steering the Machine Using Levers	4-3
Travel Mode Switch	4-4
Travel Alarm	4-5
Operating on Soft Ground	4-6
Raise One Track Using Boom and Arm	4-6
Towing Machine A Short Distance	4-7
Operating Ground Condition	4-8
Parking the Machine on Slopes	4-9
Parking the Machine	4-9

OPERATING THE MACHINE

Control Lever (ISO Pattern Loading Shovel)	5-1
Control Lever (Hitachi Pattern Loading Shovel)	5-2
Bucket Open-Close Pedals (Loading Shovel)	5-3
Pilot Control Shut-Off Lever	5-4
Engine Speed Control	5-5
Auto-Idle	5-6
Warming-Up Operation	5-7
Warming-Up the Cylinders and Motors	5-8
Operate the Machine Safely	5-9
Loading Shovel Operation	5-10
Prohibited Operation	5-10
Object Handling --- If Equipped	5-12
Overnight Storage Instructions	5-13

MAINTENANCE

Correct Maintenance and Inspection Procedures	7-1
Check the Hour Meter Regularly	7-2
Use Correct Fuels and Lubricants	7-2
Prepare Machine for Maintenance	7-3
Access Doors	7-4
Inspection/Maintenance Lights	7-5
Use A Chain To Prevent Falling Accidents	7-6
Electric Pump	7-7
Construction Outline	7-9
Hydraulic System	7-11
Loading Shovel	7-12
Periodic Replacement of Parts	7-14
Maintenance Interval Guide	7-30
A. Greasing	7-33
Loading Shovel Front Joint Pins	7-34
Swing Bearing	7-38
Swing Internal Gear	7-39
Center Joint	7-40
Operating the Lubricator	7-41

CONTENTS

B. Engine	7-43	Recirculation Air Filter	7-107
Engine Oil Level in Engine Oil Pan.....	7-44	Ventilation Air Filter	7-108
Check LED Monitor Signal		Check Refrigerant Quantity.....	7-109
(on Reserve Tank)	7-45	Check Compressor Belt Tension	7-110
Change Engine Oil in Engine Oil Pan.....	7-46	Clean Condenser Core	7-111
Replace Engine Oil Filters	7-46	Check Tightening Torque	7-112
C. Transmission.....	7-50	Seasonal Maintenance	7-113
Pump Transmission.....	7-50	I. Electrical system	7-114
Pump Transmission Gear	7-51	Batteries.....	7-114
Pump Transmission Oil Level.....	7-51	Replace Batteries.....	7-118
Change Oil.....	7-52	Replacing Fuses	7-119
Replace Filter	7-52	Power Source Terminal	7-123
Clean Breather	7-53	High Current Fuse.....	7-124
Swing Reduction Gear.....	7-54	Check Electrical Cables and	
Check Oil Level	7-54	Wire Harnesses for Short Circuits	7-125
Change Gear Oil.....	7-55	Check Emergency Engine Stop Switch	7-127
Clean Breather	7-56	J. Miscellaneous.....	7-128
Travel Reduction Gear	7-56	Check Bucket Teeth	7-129
Check Oil Level	7-56	Inspect Emergency Evacuation	
Change Gear Oil.....	7-57	Equipment and Hanger.....	7-132
D. Hydraulic system.....	7-58	Auto-Lubrication System	7-133
Inspection and Maintenance		Check and Replace Seat Belt.....	7-137
of Hydraulic Equipment	7-59	Check Windshield Washer Fluid Level.....	7-137
Check Hydraulic Oil Level	7-61	Clean Air Horn Compressor Filter.....	7-138
Drain Hydraulic Oil Tank Sump	7-63	Check Track Sag	7-139
Replace Full-Flow Filter and Drain Filter	7-64	Check Accumulator.....	7-141
Replace Bypass Filter.....	7-66	Check Side Frame Area	7-141
Replace Pilot Oil Filter	7-68	Check Tightening Torque	
Change Hydraulic Oil.....	7-70	of Bolts and Nuts	7-142
Clean Suction Filter	7-73	MAINTENANCE UNDER SPECIAL	
Replace Suction Filter	7-74	ENVIRONMENTAL CONDITIONS	
Replace High-Pressure Filter	7-75	Maintenance Under Special	
Clean Oil Cooler Core	7-77	Environmental Conditions	9-1
Check Hoses and Lines	7-78	STORAGE	
Service Recommendations for		Storing the Machine	10-1
Hydraulic Fittings	7-81	Removing the Machine from Storage	10-2
E. Fuel system	7-83	Transporting the Machine	10-2
Drain Fuel Tank Sump	7-85	TROUBLESHOOTING	
Drain Fuel Filter Sediment.....	7-85	Cummins Fault Code Lamps	
Replace Fuel Element	7-86	and Diagnostic Switches	11-1
Replace Fuel Filter	7-87	Engine	11-2
Check Fuel Hoses	7-88	Electrical System.....	11-6
Clean Fuel Cooler Core.....	7-90	Mode Selection	11-9
Clean Fuel Tank Breather	7-90	Hydraulic System	11-9
F. Air cleaner	7-91	Auto-Idle	11-12
Clean Air Cleaner Outer Element.....	7-91	SPECIFICATIONS	
Replace Air Cleaner Outer		Specifications	12-1
and Inner Elements	7-91	Working Range (Loading Shovel).....	12-2
G. Cooling system	7-93	INDEX	14-1
Check Coolant Level	7-94		
Check DCA4 Concentration in Coolant.....	7-95		
Replace Coolant Filter	7-103		
Change Coolant.....	7-104		
Clean Radiator, After Cooler Interior	7-104		
Clean Radiator, After Cooler Core.....	7-106		
H. Air conditioner	7-107		

SAFETY

RECOGNIZE SAFETY INFORMATION

- These are the **SAFETY ALERT SYMBOLS**.
 - When you see these symbols on your machine or in this manual, be alert to the potential for personal injury.
 - Follow recommended precautions and safe operating practices.

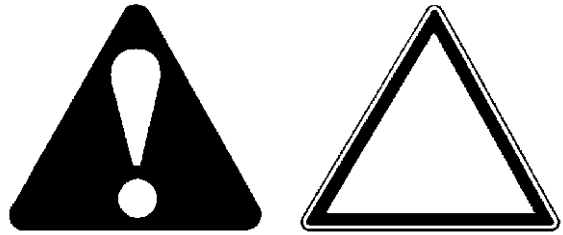

SA-688

UNDERSTAND SIGNAL WORDS

- On machine safety signs, signal words designating the degree or level of hazard - **DANGER**, **WARNING**, or **CAUTION** - are used with the safety alert symbol.
 - **DANGER** indicates an imminently hazardous situation which, if not avoided, will result in death or serious injury.
 - **WARNING** indicates a potentially hazardous situation which, if not avoided, could result in death or serious injury.
 - **CAUTION** indicates a potentially hazardous situation which, if not avoided, may result in minor or moderate injury.
 - **DANGER** or **WARNING** safety signs are located near specific hazards. General precautions are listed on **CAUTION** safety signs.
 - Some safety signs don't use any of the designated signal words above after the safety alert symbol are occasionally used on this machine.
- To avoid confusing machine protection with personal safety messages, a signal word **IMPORTANT** indicates a situation which, if not avoided, could result in damage to the machine.
-  **NOTE** indicates an additional explanation for an element of information.



SA-1223

SAFETY

FOLLOW SAFETY INSTRUCTIONS

- Carefully read and follow all safety signs on the machine and all safety messages in this manual.
- Safety signs should be installed, maintained and replaced when necessary.
 - If a safety sign or this manual is damaged or missing, order a replacement from your authorized dealer in the same way you order other replacement parts (be sure to state machine model and serial number when ordering).
- Learn how to operate the machine and its controls correctly and safely.
- Allow only trained, qualified, authorized personnel to operate the machine.
- Keep your machine in proper working condition.
 - Unauthorized modifications of the machine may impair its function and/or safety and affect machine life.
 - Do not modify any machine parts without authorization. Failure to do so may deteriorate the part safety, function, and/or service life. In addition, personal accident, machine trouble, and/or damage to material caused by unauthorized modifications will void Hitachi Warranty Policy.
 - Do not use attachments and/or optional parts or equipment not authorized by Hitachi. Failure to do so may deteriorate the safety, function, and/or service life of the machine. In addition, personal accident, machine trouble, and/or damage to material caused by using unauthorized attachments and/or optional parts or equipment will void Hitachi Warranty Policy.
- The safety messages in this SAFETY chapter are intended to illustrate basic safety procedures of machines. However it is impossible for these safety messages to cover every hazardous situation you may encounter. If you have any questions, you should first consult your supervisor and/or your authorized dealer before operating or performing maintenance work on the machine.

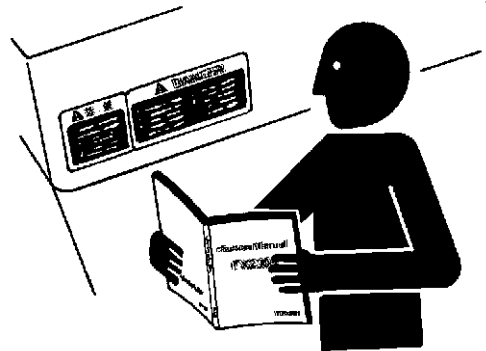

SA-003

003-E01B-0003

PREPARE FOR EMERGENCIES

- Be prepared if a fire starts or if an accident occurs.
 - Keep a first aid kit and fire extinguisher on hand.
 - Thoroughly read and understand the label attached on the fire extinguisher to use it properly.
 - To ensure that a fire-extinguisher can be always used when necessary, check and service the fire-extinguisher at the recommended intervals as specified in the fire-extinguisher manual.
 - Establish emergency procedure guidelines to cope with fires and accidents.
 - Keep emergency numbers for doctors, ambulance service, hospital, and fire department posted near your telephone.

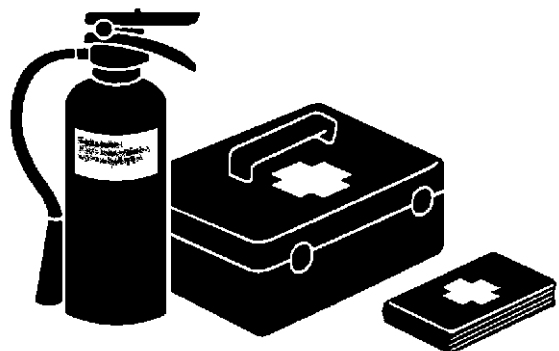

SA-437

004-E01A-0437

SAFETY

WEAR PROTECTIVE CLOTHING

- Wear close fitting clothing and safety equipment appropriate to the job.

You may need:

- A hard hat
- Safety shoes
- Safety glasses, goggles, or face shield
- Heavy gloves
- Hearing protection
- Reflective clothing
- Wet weather gear
- Respirator or filter mask.

Be sure to wear the correct equipment and clothing for the job. Do not take any chances.

- Avoid wearing loose clothing, jewelry, or other items that can catch on control levers or other parts of the machine.
- Operating equipment safely requires the full attention of the operator. Do not wear radio or music headphones while operating the machine.

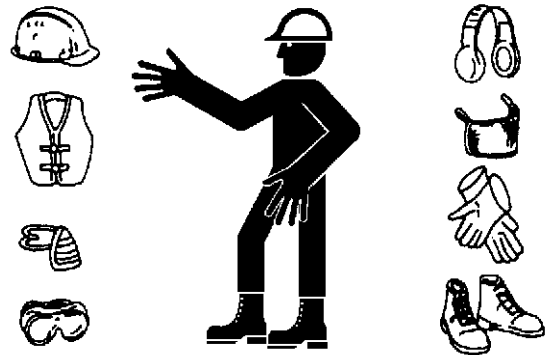

SA-438

005-E01A-0438

PROTECT AGAINST NOISE

- Prolonged exposure to loud noise can cause impairment or loss of hearing.
- Wear a suitable hearing protective device such as earmuffs or earplugs to protect against objectionable or uncomfortably loud noises.



006-E01A-0434

SA-434

INSPECT MACHINE

- Inspect your machine carefully each day or shift by walking around it before you start it to avoid personal injury.
- In the walk-around inspection, be sure to cover all points described in the “PRE-START INSPECTION” chapter in the operator’s manual.



007-E01A-0435

SA-435

SAFETY

GENERAL PRECAUTIONS FOR CAB

- Before entering the cab, thoroughly remove all dirt and/or oil from the soles of your work boots. If any controls such as a pedal is operated while with dirt and/or oil on the soles of the operator's work boots the operator's foot may slip off the pedal, possibly resulting in a personal accident.
- Do not leave parts and/or tools lying around the operator's seat. Store them in their specified locations.
- Avoid storing transparent bottles in the cab. Do not attach any transparent type window decorations on the windowpanes as they may focus sunlight, possibly starting a fire.
- Refrain from listening to the radio, or using music headphones or mobile telephones in the cab while operating the machine.
- Keep all flammable objects and/or explosives away from the machine.
- After using the ashtray, always cover it to extinguish the match and/or tobacco.
- Do not leave cigarette lighters in the cab. When the temperature in the cab increases, the lighter may explode.

524-E01A-0000

SAFETY

USE HANDHOLDS AND STEPS

- Falling is one of the major causes of personal injury.
 - When you get on and off the machine, always face the machine and maintain a three-point contact with the steps and handrails.
 - Do not use any controls as hand-holds.
 - Never jump on or off the machine. Never mount or dismount a moving machine.
 - Be careful of slippery conditions on platforms, steps, and handrails when leaving the machine.

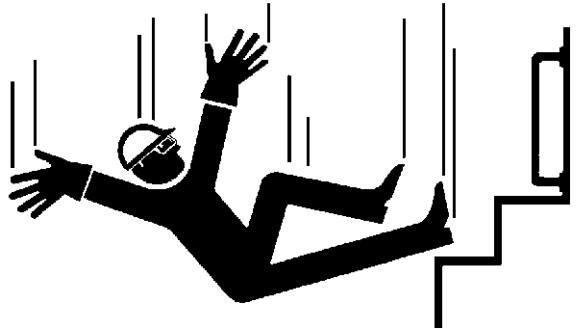

SA-439

008-E01A-0439

ADJUST THE OPERATOR'S SEAT

- A poorly adjusted seat for either the operator or for the work at hand may quickly fatigue the operator leading to misoperations.
 - The seat should be adjusted whenever changing the operator for the machine.
 - The operator should be able to fully depress the pedals and to correctly operate the control levers with his back against the seat back.
 - If not, move the seat forward or backward, and check again.
 - Adjust the rear view mirror position so that the best rear visibility is obtained from the operator's seat. If the mirror is broken, immediately replace it with a new one.



SA-378

009-E01A-0462

ENSURE SAFETY BEFORE RISING FROM OR LEAVING OPERATOR'S SEAT

- Before rising from the operator's seat to open/close either side window or to adjust the seat position, be sure to first lower the front attachment to the ground and then move the pilot control shut-off lever to the LOCK position. Failure to do so may allow the machine to unexpectedly move when a body part unintentionally comes in contact with a control lever, possibly resulting in serious personal injury or death.
 - Before leaving the machine, be sure to first lower the front attachment to the ground and then move the pilot control shut-off lever to the LOCK position. Press and hold the engine stop switch until stopping the engines completely. Remove the key from the key switch.
 - Before leaving the machine, close all windows, doors, and access covers and lock them up.

SAFETY

FASTEN YOUR SEAT BELT

- If the machine should overturn, the operator may become injured and/or thrown from the cab. Additionally the operator may be crushed by the overturning machine, resulting in serious injury or death.
- Prior to operating the machine, thoroughly examine webbing, buckle and attaching hardware. If any item is damaged or worn, replace the seat belt or component before operating the machine.
- Be sure to remain seated with the seat belt securely fastened at all times when the machine is in operation to minimize the chance of injury from an accident.
- We recommend that the seat belt be replaced every three years regardless of its apparent condition.



SA-237

010-E01A-0237

MOVE AND OPERATE MACHINE SAFELY

- Bystanders can be run over.
- Take extra care not to run over bystanders. Confirm the location of bystanders before moving, swinging, or operating the machine.
- Always keep the travel alarm and horn in working condition (if equipped). It warns people when the machine starts to move.
- Use a signal person when moving, swinging, or operating the machine in congested areas. Coordinate hand signals before starting the machine.
- Use appropriate illumination. Check that all lights are operable before operating the machine. If any faulty illumination is present, immediately repair it.

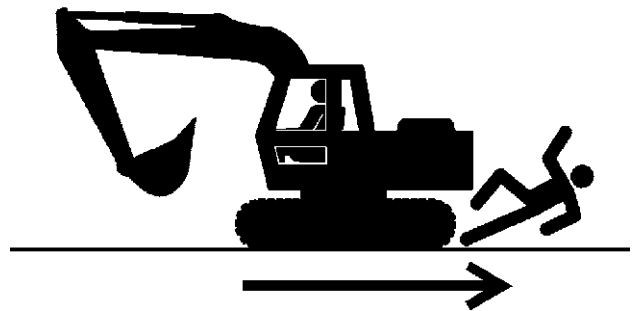

SA-426

011-E01A-0398

HANDLE STARTING AIDS SAFELY

Starting fluid:

- Starting fluid is highly flammable.
 - Keep all sparks and flame away when using it.
 - Keep starting fluid well away from batteries and cables.
 - Remove container from machine if engine does not need starting fluid.
 - To prevent accidental discharge when storing a pressurized container, keep the cap on the container, and store it in a cool, well-protected location.
 - Do not incinerate or puncture a starting fluid container.



SA-293

036-E01A-0293-3

SAFETY

OPERATE ONLY FROM OPERATOR'S SEAT

- Inappropriate engine starting procedures may cause the machine to runaway, possibly resulting in serious injury or death.
- Start the engine only from the operator's seat.
- NEVER start the engine while standing on the track or on ground.
- Do not start engine by shorting across starter terminals.
- Before starting the engine, confirm that all control levers are in neutral.
- Before starting the engine, confirm the safety around the machine and sound the horn to alert bystanders.



SA-444

012-E01B-0444

JUMP STARTING

- Battery gas can explode, resulting in serious injury.
- If the engine must be jump started, be sure to follow the instructions shown in the "OPERATING THE ENGINE" chapter in the operator's manual.
- The operator must be in the operator's seat so that the machine will be under control when the engine starts. Jump starting is a two-person operation.
- Never use a frozen battery.
- Failure to follow correct jump starting procedures could result in a battery explosion or a runaway machine.

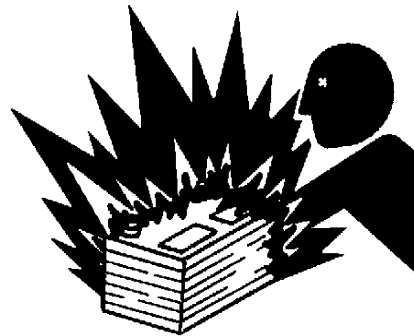

SA-032

S013-E01A-0032

KEEP RIDERS OFF MACHINE

- Riders on machine are subject to injury such as being struck by foreign objects and being thrown off the machine.
- Only allow the operator on the machine. Keep riders off.
- Riders also obstruct the operator's view, resulting in the machine being operated in an unsafe manner.

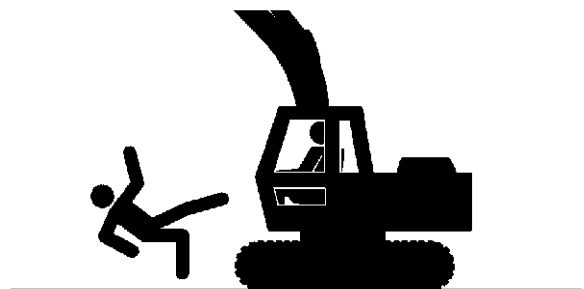

SA-379

014-E01B-0379

SAFETY

PRECAUTIONS FOR OPERATIONS

- Investigate the work site before starting operations.
- Be sure to wear close fitting clothing and safety equipment appropriate for the job, such as a hard hat, etc. when operating the machine.
- Clear all persons and obstacles from area of operation and machine movement.
Always beware of the surroundings while operating. When working in a small area surrounded by obstacles, take care not to hit the upperstructure against obstacles.
- When loading onto trucks, bring the bucket over the truck beds from the rear side. Take care not to swing the bucket over the cab or over any person.

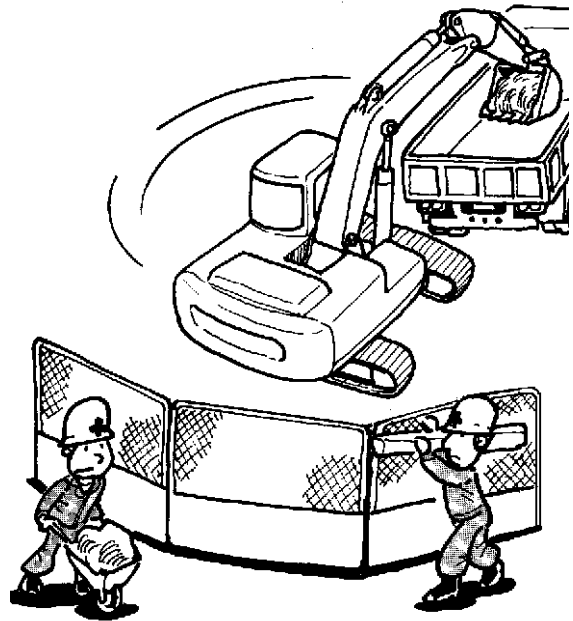

M104-05-015

SAFETY

INVESTIGATE JOB SITE BEFOREHAND

- When working at the edge of an excavation or on a road shoulder, the machine could tip over, possibly resulting in serious injury or death.
 - Investigate the configuration and ground conditions of the job site beforehand to prevent the machine from falling and to prevent the ground, stockpiles, or banks from collapsing.
 - Make a work plan. Use machines appropriate to the work and job site.
 - Reinforce ground, edges, and road shoulders as necessary. Keep the machine well back from the edges of excavations and road shoulders.
 - When working on an incline or on a road shoulder, employ a signal person as required.
 - Confirm that your machine is equipped a FOPS cab before working in areas where the possibility of falling stones or debris exist.
 - When the footing is weak, reinforce the ground before starting work.
 - When working on frozen ground, be extremely alert. As ambient temperatures rise, footing becomes loose and slippery.
 - Beware the possibility of fire when operating the machine near flammable objects such as dry grass.
- Make sure the worksite has sufficient strength to firmly support the machine.

When working close to an excavation or at road shoulders, operate the machine with the tracks positioned perpendicular to the cliff face with travel motors at the rear, so that the machine can more easily evacuate if the cliff face collapses.
- If working on the bottom of a cliff or a high bank is required, be sure to investigate the area first and confirm that no danger of the cliff or bank collapsing exists. If any possibility of cliff or bank collapsing exists, do not work on the area.
- Soft ground may collapse when operating the machine on it, possibly causing the machine to tip over. When working on a soft ground is required, be sure to reinforce the ground first using large pieces of steel plates strong and firm enough to easily support the machine.
- Note that there is always a possibility of machine tipping over when working on rough terrain or on slopes. Prevent machine tipping over from occurring. When operating on rough terrain or on slopes:
 - Reduce the engine speed.
 - Select slow travel speed mode.
 - Operate the machine slowly and be cautious with machine movements.

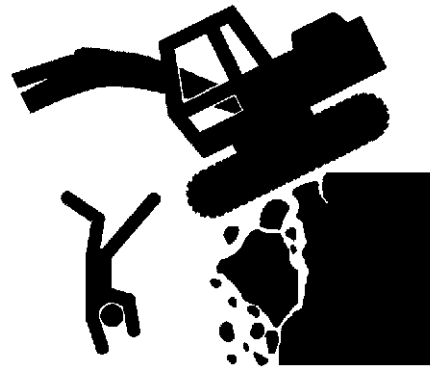

SA-0380

SAFETY

PROTECT AGAINST FALLING STONES AND DEBRIS

- Confirm that your machine is FOPS cab equipped before working in areas where the possibility of falling stones or debris exist.

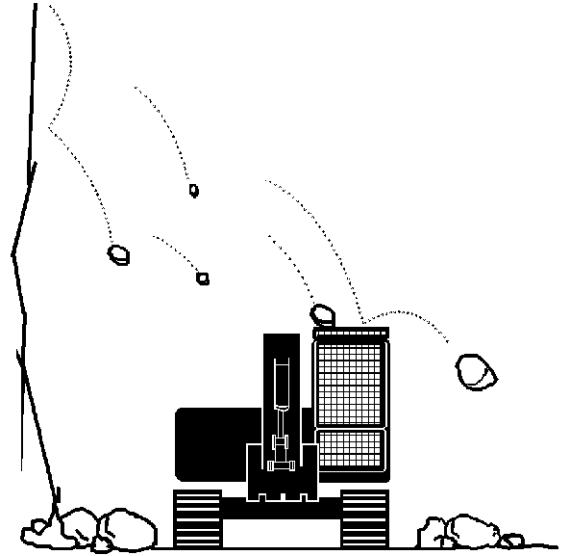

SA-490

PROVIDE SIGNALS FOR JOBS INVOLVING MULTIPLE NUMBERS OF MACHINES

- For jobs involving multiple numbers of machines, provide signals commonly known by all personnel involved. Also, appoint a signal person to coordinate the job site. Make sure that all personnel obey the signal person's directions.

018-E01A-0481



SA-481

CONFIRM DIRECTION OF MACHINE TO BE DRIVEN

- Incorrect travel pedal/lever operation may result in serious injury death.
- Before driving the machine, confirm the position of the undercarriage in relation to the operator's position. If the travel motors are located in front of the cab, the machine will move in reverse when travel pedals/levers are operated to the front.

017-E01A-0491

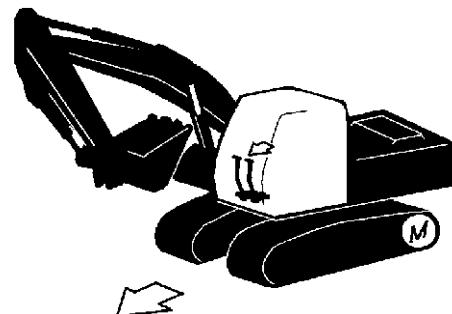

SA-491

SAFETY

DRIVE MACHINE SAFELY

- Before driving the machine, always confirm that the travel levers/pedals direction corresponds to the direction you wish to drive.

- Be sure to detour around any obstructions.
- Avoid traveling over obstructions. Soil, fragments of rocks, and/or metal pieces may scatter around the machine. Do not allow personnel to stay around the machine while traveling.

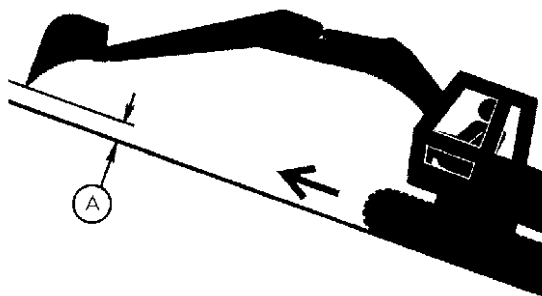

SA-387

- Driving on a slope may cause the machine to slip or overturn, possibly resulting in serious injury or death.

- Never attempt to ascend or descend 30 degrees or steeper slopes.
- Be sure to fasten the seat belt.
- When driving up or down a slope, keep the bucket facing the direction of travel, approximately 0.5 to 1.0 m (A) above the ground.
- If the machine starts to skid or becomes unstable, immediately lower the bucket to the ground and stop.

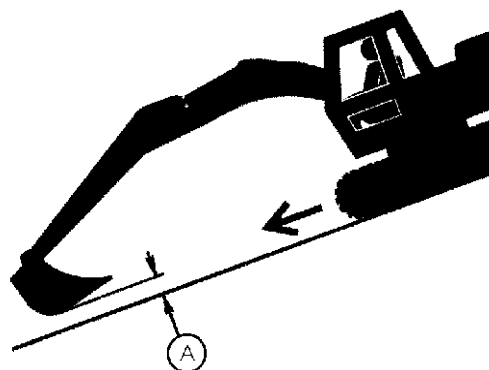

SA-388

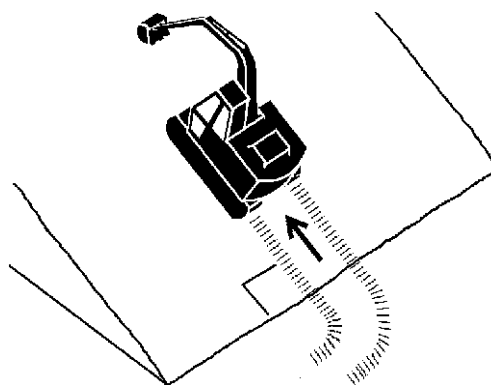

SA-441

- Driving across the face of a slope or steering on a slope may cause the machine to skid or turnover. If the direction must be changed, move the machine to level ground, then, change the direction to ensure safe operation.
- Avoid swinging the upperstructure on slopes. Never attempt to swing the upperstructure downhill. The machine may tip over. If swinging uphill is unavoidable, carefully operate the upperstructure and boom at slow speed.

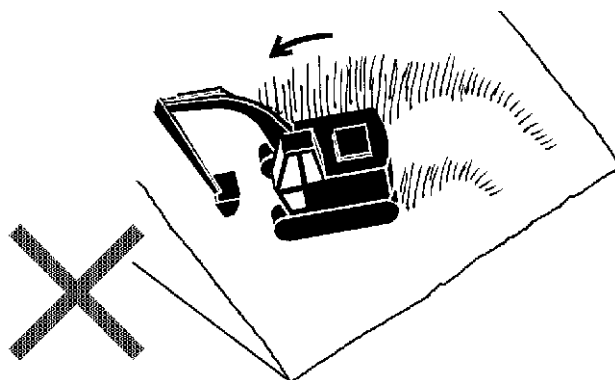

SA-442

SAFETY

- Be sure to fully pull up the stairway before traveling.
- If the engine stalls on a slope, immediately lower the bucket to the ground. Return the control levers to neutral. Then, restart the engines.
- Be sure to thoroughly warm up the machine before ascending steep slopes. If hydraulic oil has not warmed up sufficiently, sufficient performance may not be obtained.
- Before descending a slope, turn the travel mode switch to the SLOW position on level ground. Do not operate the travel mode switch while descending a slope. The machine may slip, possibly causing safety accident.
- When descending a steep slope, avoid quick start or stop traveling in the FAST mode. Failure to do so may result in damage to the travel motor.
- Use a signal person when moving, swinging or operating the machine in congested areas. Coordinate hand signals before starting the machine.
- Before moving machine, determine which way to move travel pedals/levers for the direction you want to go. When the travel motors are in the rear, pushing down on the front of the travel pedals or pushing the levers forward moves the machine forward, towards the idlers.
- Select a travel route that is as flat as possible. Steer the machine as straight as possible, making small gradual changes in direction.
- When traveling on a level surface, position the front with boom (1) fully raised, and arm (2) fully retracted, as illustrated, in order to apply the road as evenly as possible to all of the lower rollers.
- Before traveling on them, check the strengths of bridges and road shoulders, and reinforce if necessary.
- Do not make contact with electric wires or bridges.
- When crossing a river, measure the depth of the river using the bucket, and cross slowly. Do not cross the river when the depth of the river is deeper than the upper edge of the upper roller.
- When traveling on rough terrain, reduce engine speed. Select slow travel speed. Slower speed will reduce possible damage to the machine.
- Avoid operations that may damage the track and undercarriage components.
- During freezing weather, always clean snow and ice from track shoes before loading and unloading machine, to prevent the machine from slipping.

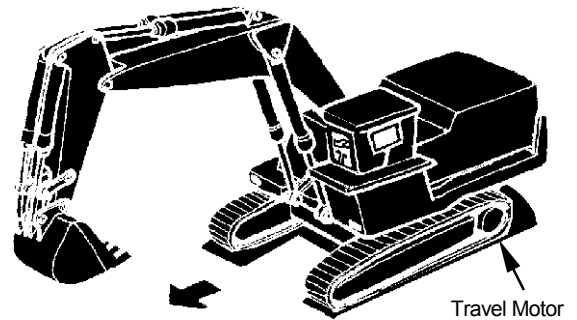

M145-05-003

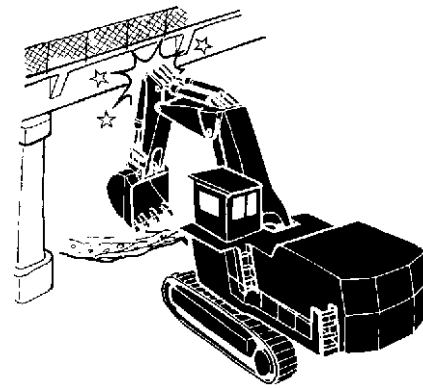

M145-05-004



M145-05-027

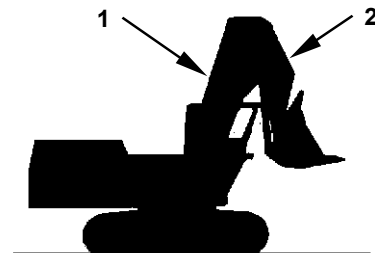

M145-05-022

SAFETY

AVOID INJURY FROM ROLLAWAY ACCIDENTS

- Death or serious injury may result if you attempt to mount or stop a moving machine.

To avoid rollaways:

- Select level ground when possible to park machine.
- Do not park the machine on a grade.
- Lower the bucket and/or other work tools to the ground.
- Turn the auto-idle switch and the H/P mode switch off.
- Run the engine at slow idle speed without load for 5 minutes to cool down the engine.
- Stop the engine and remove the key from the key switch.
- Pull the pilot control shut-off lever to LOCK position.
- Block both tracks and lower the bucket to the ground. Thrust the bucket teeth into the ground if you must park on a grade.
- Position the machine to prevent rolling.
- Park a reasonable distance from other machines.

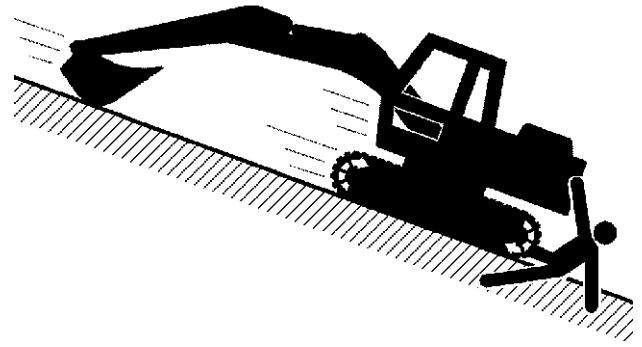

SA-391

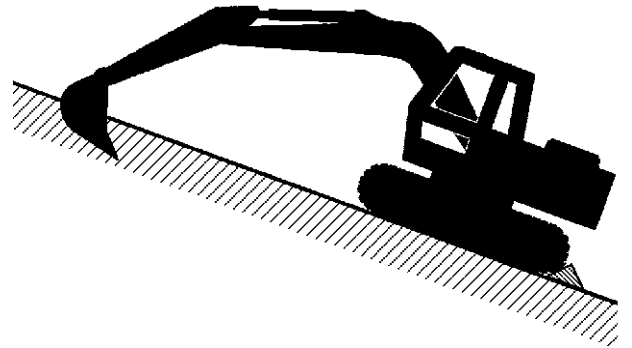

SA-392

020-E02A-0493

Thank you so much for reading.
Please click the “Buy Now!”
button below to download the
complete manual.



After you pay.

You can download the most
perfect and complete manual in
the world immediately.

Our support email:

ebooklibonline@outlook.com