

Operator's Manual

ZAXIS

210-5G • 210LC-5G

250LC-5G

350LC-5G

Hydraulic Excavator

Serial No.

ZX210-5G, 210LC-5G 300001 and up

ZX250LC-5G 030001 and up

ZX350LC-5G 040001 and up

INDEX

MACHINE NUMBERS

SAFETY

SAFETY SIGNS

COMPONENTS NAME

GETTING ON/OFF THE MACHINE

OPERATOR'S STATION

BREAK-IN

OPERATING THE ENGINE

DRIVING THE MACHINE

OPERATING THE MACHINE

TRANSPORTING

MAINTENANCE

MAINTENANCE UNDER SPECIAL ENVIRONMENTAL CONDITIONS

STORAGE

TROUBLESHOOTING

SPECIFICATIONS

INDEX

CONTENTS

MACHINE NUMBERS	1
SAFETY	
Recognize Safety Information	S-1
Understand Signal Words.....	S-1
Follow Safety Instructions.....	S-2
Prepare for Emergencies.....	S-3
Wear Protective Clothing.....	S-3
Protect Against Noise	S-4
Inspect Machine	S-4
General Precautions for Cab.....	S-5
Use Handholds and Steps	S-6
Adjust the Operator's Seat.....	S-6
Ensure Safety Before Rising from or Leaving Operator's Seat.....	S-7
Fasten Your Seat Belt.....	S-7
Move and Operate Machine Safely.....	S-8
Operate Only from Operator's Seat	S-8
Jump Starting.....	S-9
Keep Riders off Machine	S-9
Precautions for Operations	S-10
Investigate Job Site Beforehand	S-11
Install OPG Guard.....	S-12
Provide Signals for Jobs Involving Multiple Machines....	S-13
Confirm Direction of Machine to Be Driven.....	S-13
Drive Machine Safely.....	S-14
Avoid Injury from Rollaway Accidents.....	S-16
Avoid Injury from Back-Over and Swing Accidents	S-17
Keep Person Clear from Working Area.....	S-18
Never Position Bucket Over Anyone	S-18
Avoid Undercutting.....	S-19
Avoid Tipping.....	S-19
Never Undercut a High Bank.....	S-20
Dig with Caution.....	S-20
Operate with Caution	S-20
Avoid Power Lines.....	S-21
Precautions for Lightning.....	S-21
Object Handling	S-22
Protect Against Flying Debris	S-22
Park Machine Safely.....	S-23
Handle Fluids Safely–Avoid Fires.....	S-23
Transport Safely	S-24
Practice Safe Maintenance.....	S-25
Warn Others of Service Work	S-26
Support Machine Properly.....	S-26
Stay Clear of Moving Parts	S-27
Prevent Parts from Flying	S-27
Store Attachments Safely	S-28
Prevent Burns.....	S-28
Replace Rubber Hoses Periodically.....	S-29
Avoid High-Pressure Fluids	S-29
Prevent Fires.....	S-30
Evacuating in Case of Fire.....	S-32
Beware of Exhaust Fumes.....	S-32
Precautions for Welding and Grinding	S-33
Avoid Heating Near Pressurized Fluid Lines	S-34
Avoid Applying Heat to Lines Containing Flammable Fluids.....	S-34
Precautions for Handling Accumulator and Gas Damper	S-34
Remove Paint Before Welding or Heating	S-35
Beware of Asbestos and Silicon Dust and Other Contamination.....	S-35
Prevent Battery Explosions	S-36
Service Air Conditioning System Safely	S-36
Handle Chemical Products Safely.....	S-37
Dispose of Waste Properly.....	S-37
Never Ride Attachment.....	S-37
Notes on Protection of Operator's Station When the Machine Rolls Over.....	S-38
SAFETY SIGNS	S-39
COMPONENTS NAME	1-1
Components Name	1-1
GETTING ON/OFF THE MACHINE	1-2
OPERATOR'S STATION	
Cab Features (Std. Model)	1-3
Multi Function Monitor	1-4
Default Setting.....	1-5
Basic Screen.....	1-6
How to Use Screens.....	1-7
Displaying Basic Screen	1-7
Hour Meter	1-10
Clock.....	1-10
Fuel Gauge	1-10
Coolant Temperature Gauge	1-10
Operating Status Icon Display.....	1-10
Security Functions	1-11
Input Password	1-11
Extending Password Duration Time.....	1-12
Alarm Occurrence Screen.....	1-13
Remedy	1-15
Main Menu.....	1-18
Air Conditioner.....	1-19
Circulation Air Mode.....	1-19
Air Conditioner Compressor ON/OFF	1-19
Radio	1-20
Work Mode	1-21
Attachment Selection	1-21
Setting Menu	1-22
Date and Time.....	1-23
Time Adjustment	1-23
Date Adjustment.....	1-25
Display Mode Setting.....	1-27
Attachment Adjust.....	1-29
Flow Rate Adjustment.....	1-29
Priority (arm roll-out)	1-31
Attachment Name Input.....	1-33
Password Change.....	1-35
Sub Meter.....	1-39
Rear View Camera Monitor (Option).....	1-41

CONTENTS

Rear View Camera ON/OFF	1-41	Tips for Optimal Air Conditioner Usage	1-93
Brightness Adjustment.....	1-43	For Rapid Cooling	1-93
Language Settings.....	1-45	When Windows Become Clouded	1-93
Lists of Display Language.....	1-47	Off-Season Air Conditioner Maintenance.....	1-93
Unit Selection	1-48	AM/FM Radio Operation.....	1-94
Display Item Selection (Rear View Camera OFF)	1-50	Controls on the Radio.....	1-94
Main Menu Sequence Change	1-52	Tuning Procedure	1-94
Information Menu.....	1-54	Station Presetting Procedure.....	1-95
Operation	1-55	Station Auto-Presetting Procedure	1-96
Breaker Operation	1-55	TONE Control.....	1-97
Attachment Operation.....	1-57	Audio Input (Optional)	1-98
Travel Operation.....	1-59	Cab Door Release Lever	1-99
Actual Operation.....	1-61	Opening/Closing and Removing	
Maintenance	1-63	Cab Inside Window.....	1-100
Time Remains and Maintenance Interval.....	1-65	Opening Upper Front Window	1-101
Troubleshooting	1-67	Opening Upper Front Window	1-101
Monitoring.....	1-69	Removing and Storing Lower Front Window.....	1-102
Switch Panel.....	1-71	Removing and Storing Lower Front Window	1-102
Return to Previous Screen (Monitor)	1-72	Opening Side Windows.....	1-103
Return to Basic Screen (Monitor)	1-72	Opening/Closing Overhead Window.....	1-104
Selector Knob (Monitor)	1-72	Opening/Closing Overhead Window	
Temperature Control Switch/Mode Switch		(Clear Hatch: If Equipped).....	1-105
(Air Conditioner)	1-72	Emergency Exit	1-106
AUTO/OFF Switch/Fan Switch (Air Conditioner).....	1-72	Adjusting Operator's Seat	1-108
AM/FM Selector/Tuning Switch (Radio).....	1-73	Seat Height and Angle Adjustment	1-108
Power Switch/Volume Control Knob (Radio)	1-73	Console and Seat Fore-aft Adjustment.....	1-108
Engine Control Dial	1-73	Seat Fore-Aft Adjustment	1-108
Auto-Idle Switch.....	1-74	Suspension Adjustment.....	1-108
Travel Mode Switch	1-74	Backrest Adjustment	1-109
Mode Switch.....	1-75	Armrest Adjustment	1-109
Work Light Switch.....	1-75	Console Height Adjustment.....	1-110
Wiper/Washer Switch	1-76	Adjusting Procedures	1-110
Numeric Keypad.....	1-77	Installation and Adjustment of Mirrors	1-111
Switch Panel (for Optional Equipments).....	1-78	Seat Belt.....	1-112
Travel Alarm Deactivation Switch.....	1-79	Seat Belt.....	1-112
Rear Light Switch (Optional)	1-79		
Key Switch.....	1-80	BREAK-IN	
Power Boost Switch	1-80	Observe Engine Operation Closely.....	2-1
Horn Switch	1-80	Every 8 Hours or Daily.....	2-1
Cigar Lighter.....	1-81	After the First 50 Hours	2-1
Using Cigar Lighter.....	1-81	After the First 100 Hours.....	2-1
Using Cigar Lighter Port as External Power Source....	1-81		
Cab Light Switch.....	1-82	OPERATING THE ENGINE	
Installing Fire Extinguisher (Optional)	1-82	Inspect Machine Daily Before Starting	3-1
Pilot Control Shut-Off Lever	1-83	Before Starting Engine	3-2
Engine Stop Switch.....	1-84	Starting the Engine.....	3-3
Handle (Emergency engine stop).....	1-84	Check Instruments After Starting.....	3-7
Fuse Box.....	1-85	Using Booster Batteries	3-8
Auto Air Conditioner	1-86	Stopping the Engine	3-10
Features:.....	1-86		
Components Name	1-87	DRIVING THE MACHINE	
Controller Part Name and Function	1-88	Drive the Machine Carefully	4-1
Cab Heater Operation	1-90	Steering the Machine Using Pedals	4-2
Cooling Operation.....	1-91	Steering the Machine Using Levers	4-3
Defroster Operation.....	1-92	Travel Mode Switch	4-4
Cool Head/Warm Feet Operation.....	1-92	Travel Alarm.....	4-4
		Operating on Soft Ground	4-5

CONTENTS

Raise One Track Using Boom and Arm	4-5	Kind of Oils.....	7-15
Towing Machine a Short Distance.....	4-6	A. Greasing.....	7-18
Operating in Water or Mud.....	4-7	Front Joint Pins	7-18
Parking the Machine on Slopes.....	4-8	Swing Bearing	7-20
Parking the Machine	4-8	Swing Internal Gear.....	7-21
OPERATING THE MACHINE		B. Engine.....	7-22
Control Lever (ISO Pattern)	5-1	Engine Oil Level.....	7-22
Attachment Pedal (Hydraulic Breaker) (Optional)	5-2	Change Engine Oil, Replace Engine Oil Filter	7-23
Attachment Pedal (Hydraulic Crusher) (Optional).....	5-3	C. Transmission.....	7-25
Pilot Control Shut-Off Lever	5-4	Pump Transmission	7-25
Warming Up Operation.....	5-5	Swing Device.....	7-26
Engine Speed Control.....	5-6	Travel Reduction Gear	7-27
Auto-Idle.....	5-7	D. Hydraulic System.....	7-29
Auto-Idle ON/OFF	5-8	Inspection and Maintenance of Hydraulic	
Work Mode	5-9	Equipment.....	7-29
Power Boost Switch	5-12	Check Hydraulic Oil Level	7-33
Power Mode	5-13	Change Hydraulic Oil.....	7-34
Operating Backhoe.....	5-14	Suction Filter Cleaning.....	7-36
Shovel.....	5-15	Replacement of Full-Flow Filter	7-37
Grading Operation.....	5-16	Replace Pilot Oil Filter.....	7-40
Do Not Strike the Ground with Bucket Teeth	5-17	Replace Air Breather Element.....	7-41
Avoid Hammer Work.....	5-17	Check Hoses and Lines	7-42
Avoid Abusive Operation	5-18	E. Fuel System	7-46
Avoid Side Load the Bucket.....	5-18	Recommended Fuel.....	7-46
Do Not Use Wide Track Shoes on Rough Ground.	5-19	Drain Fuel Tank Sump.....	7-47
Hydraulic Breaker, Hydraulic Crusher and		Check Water Separator	7-48
Quick Coupler.....	5-20	Replace Fuel Cartridge Filter.....	7-50
Pipings for Breaker and Crusher (Optional)	5-21	Clean Feed Pump Strainer	7-51
Precautions for Breaker Operation.....	5-22	Check Fuel Hoses	7-52
Change Hydraulic Oil and Replace Full-Flow		F. Air Cleaner.....	7-53
Filter Element	5-26	Clean and Replace Air Cleaner Element	7-53
Precautions for Crusher Operation	5-27	G. Cooling System	7-55
Attachment.....	5-30	Check Coolant Level	7-56
Allowable Weight Limits of Installed Attachment	5-30	Check and Adjust Fan Belt Tension.....	7-57
Attachment Connection Parts.....	5-34	Change Coolant.....	7-58
Precaution for Arm Roll-In/Bucket Roll-In Combined		Clean Radiator/Oil Cooler/Inter Cooler Core.....	7-59
Operation.....	5-36	Clean Oil Cooler, Radiator and Inter Cooler	
Shackle Hole Usage	5-36	Front Screen	7-60
How to Lower Boom in Case of Emergency and When		Clean Air Conditioner Condenser	7-60
Engine Stops.....	5-37	H. Electrical System.....	7-61
Precautions for After Operations.....	5-38	Battery.....	7-62
TRANSPORTING		Replacing Fuses.....	7-67
Transporting by Road	6-1	I. Miscellaneous.....	7-69
Loading/Unloading on a Trailer	6-2	Check and Replace Bucket Teeth	7-69
Fastening Machine for Transporting	6-5	Change Bucket.....	7-72
Unloading	6-5	Convert Bucket Connection Into Face Shovel	7-73
Lifting Machine	6-7	Adjust Bucket Linkage	7-74
MAINTENANCE		Remove Travel Levers	7-75
Correct Maintenance and Inspection Procedures.....	7-1	Check and Replace Seat Belt.....	7-75
Check the Hour Meter Regularly.....	7-3	Check Windshield Fluid Level.....	7-76
Maintenance Guide Table	7-4	Check Track Sag.....	7-77
Preparations for Inspection and Maintenance	7-6	Clean and Replace Air Conditioner Filter	7-80
Hood and Access Covers.....	7-7	Check Air Conditioner	7-82
Maintenance Guide	7-9	Clean Cab Floor.....	7-84
Periodic Replacement of Parts.....	7-14	Check Injection Nozzle	7-85
		Retighten Cylinder Head Bolt.....	7-85

CONTENTS

Inspect and Adjust Valve Clearance	7-85
Check Injection Timing	7-85
Measure Engine Compression Pressure.....	7-85
Check Starter and Alternator	7-85
Replace Water Pump Grease	7-85
Check Gas Damper	7-86
Tightening and Retightening Torque of Nuts and Bolts.....	7-86

MAINTENANCE UNDER SPECIAL ENVIRONMENTAL CONDITIONS

Maintenance Under Special Environmental Conditions	9-1
---	-----

STORAGE

Storing the Machine.....	10-1
--------------------------	------

TROUBLESHOOTING

Troubleshooting	11-1
-----------------------	------

SPECIFICATIONS

Specifications.....	12-1
ZX210-5G, 210LC-5G.....	12-1
Working Ranges (Grouser shoe).....	12-2
ZX210-5G, 210LC-5G.....	12-2
Shoe Types and Applications	12-3
ZX210-5G	12-3
ZX210LC-5G	12-3
Bucket Types and Applications	12-4
ZX210-5G, 210LC-5G.....	12-4
Specifications.....	12-5
ZX250LC-5G	12-5
Working Ranges (Grouser shoe).....	12-6
ZX250LC-5G	12-6
Shoe Types and Applications	12-7
ZX250LC-5G	12-7
Bucket Types and Applications	12-8
ZX250LC-5G	12-8
Specifications.....	12-9
ZX350LC-5G	12-9
Working Ranges (Grouser shoe).....	12-10
ZX350LC-5G	12-10
Shoe Types and Applications	12-11
ZX350LC-5G	12-11
Bucket Types and Applications	12-12
ZX350LC-5G	12-12

INDEX.....	14-1
-------------------	-------------

MACHINE NUMBERS

The manufacturing Nos. explained in this group is the individual number (serial No.) given to each machine and hydraulic components. These numbers are requested when inquiring any information on the machine and/or components. Fill these serial Nos. in the blank spaces in this group to immediately make them available upon request.

Machine

TYPE : _____

PRODUCT IDENTIFICATION NUMBER : _____

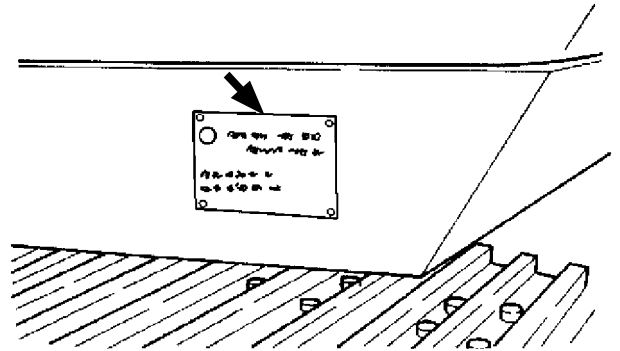

M157-00-001

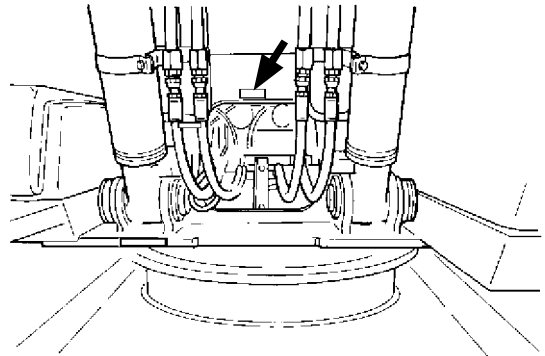

M157-12-008

Product Identification Number

NOTE:

1F9DCDXDC33001 Marks to indicate the start and end of the PIN

 PRODUCT IDENTIFICATION NUMBER (PIN)

Engine

TYPE : _____

MFG. NO. : _____

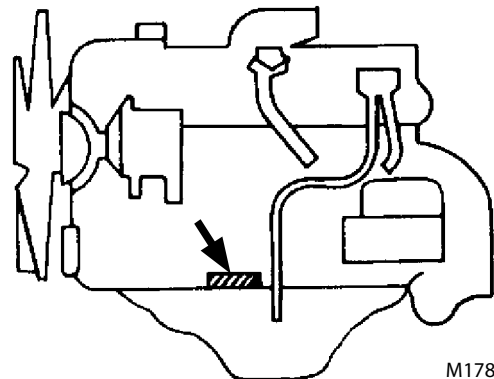

M178-00-001

ZX210-5G, 210LC-5G, 250LC-5G

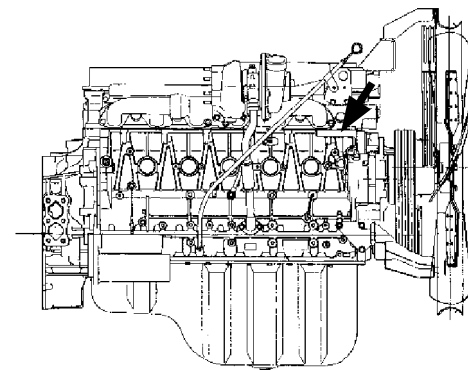

ZX350LC-5G

M1HH-07-001

MACHINE NUMBERS

Travel Motor

TYPE : _____

MFG. NO. : _____

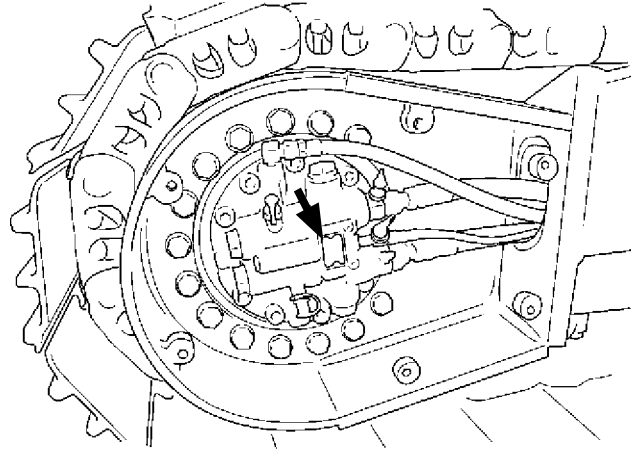

M178-07-047

Swing Motor

TYPE : _____

MFG. NO. : _____

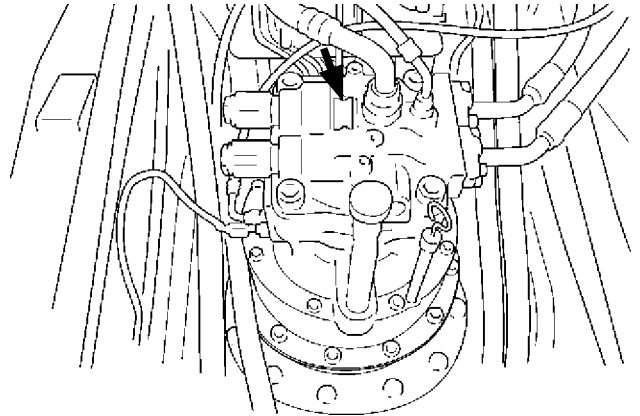

M178-07-086

Hydraulic Pump

TYPE : _____

MFG. NO. : _____

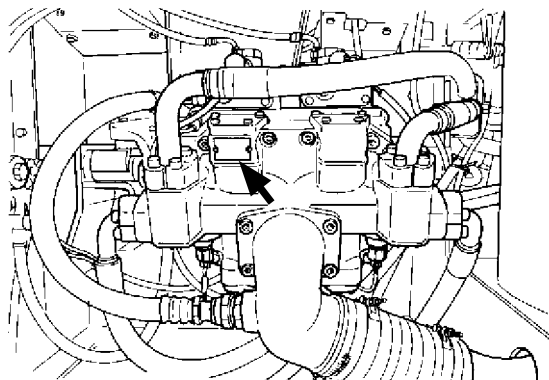

M157-00-004

SAFETY

Recognize Safety Information

- These are the **SAFETY ALERT SYMBOLS**.
 - When you see these symbols on your machine or in this manual, be alert to the potential for personal injury.
 - Follow recommended precautions and safe operating practices.

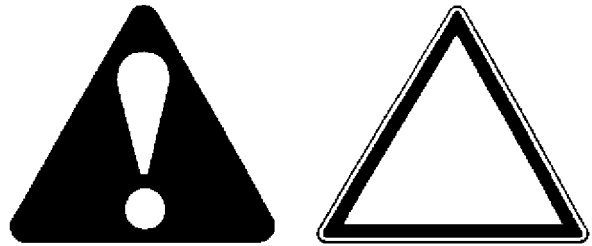

SA-688

Understand Signal Words

- On machine safety signs, signal words designating the degree or level of hazard - **DANGER**, **WARNING**, or **CAUTION** - are used with the safety alert symbol.
 - **DANGER** indicates an imminently hazardous situation which, if not avoided, will result in death or serious injury.
 - **WARNING** indicates a potentially hazardous situation which, if not avoided, could result in death or serious injury.
 - **CAUTION** indicates a potentially hazardous situation which, if not avoided, may result in minor or moderate injury.
 - **DANGER or WARNING safety signs** are located near specific hazards. General precautions are listed on **CAUTION safety signs**.
 - Some safety signs do not use any of the designated signal words above after the safety alert symbol are occasionally used on this machine.



IMPORTANT



- To avoid confusing machine protection with personal safety messages, a signal word **IMPORTANT** indicates a situation which, if not avoided, could result in damage to the machine.
-  **NOTE**: indicates an additional explanation for an element of information.

SA-1223

SAFETY

Follow Safety Instructions

- Carefully read and follow all safety signs on the machine and all safety messages in this manual.
- Safety signs should be installed, maintained and replaced when necessary.
 - If a safety sign or this manual is damaged or missing, order a replacement from your authorized dealer in the same way you order other replacement parts (be sure to state machine model and serial number when ordering).
- Learn how to operate the machine and its controls correctly and safely.
- Allow only trained, qualified, authorized personnel to operate the machine.
- Keep your machine in proper working condition.
 - Unauthorized modifications of the machine may impair its function and/or safety and affect machine life.
 - Do not modify any machine parts without authorization. Failure to do so may deteriorate the part safety, function, and/or service life. In addition, personal accident, machine trouble, and/or damage to material caused by unauthorized modifications will void Hitachi Warranty Policy.
 - Never attempt to modify or disassemble the inlet/exhaust parts and the muffler filter. Avoid giving shocks on the muffler filter by striking elements with other objects or dropping the elements. Failure to do so may affect the exhaust gas purifying device, possibly damaging it or lowering its performance.
 - Do not use attachments and/or optional parts or equipment not authorized by Hitachi. Failure to do so may deteriorate the safety, function, and/or service life of the machine. In addition, personal accident, machine trouble, and/or damage to material caused by using unauthorized attachments and/or optional parts or equipment will void Hitachi Warranty Policy.
- The safety messages in this SAFETY chapter are intended to illustrate basic safety procedures of machines. However it is impossible for these safety messages to cover every hazardous situation you may encounter. If you have any questions, you should first consult your supervisor and/or your authorized dealer before operating or performing maintenance work on the machine.

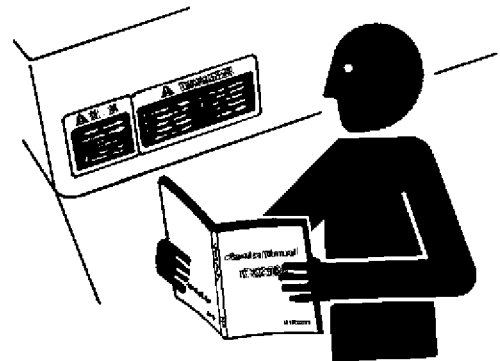

SA-003

SAFETY

Prepare for Emergencies

- Be prepared if a fire starts or if an accident occurs.
 - Keep a first aid kit and fire extinguisher on hand.
 - Thoroughly read and understand the label attached on the fire extinguisher to use it properly.
 - To ensure that a fire extinguisher can be always used when necessary, check and service the fire extinguisher at the recommended intervals as specified in the fire extinguisher manual.
 - Establish emergency procedure guidelines to cope with fires and accidents.
 - Keep emergency numbers for doctors, ambulance service, hospital, and fire department posted near your telephone.

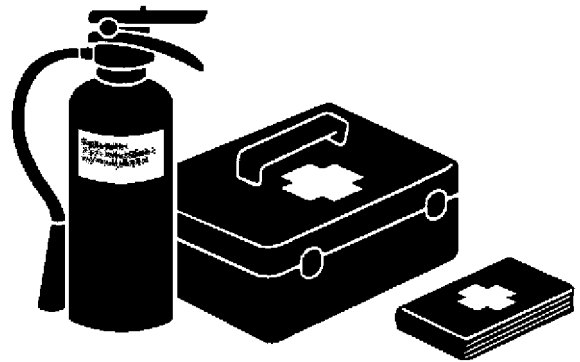

SA-437

Wear Protective Clothing

- Wear close fitting clothing and safety equipment appropriate to the job.

You may need:

- A hard hat
- Safety shoes
- Safety glasses, goggles, or face shield
- Heavy gloves
- Hearing protection
- Reflective clothing
- Wet weather gear
- Respirator or filter mask.

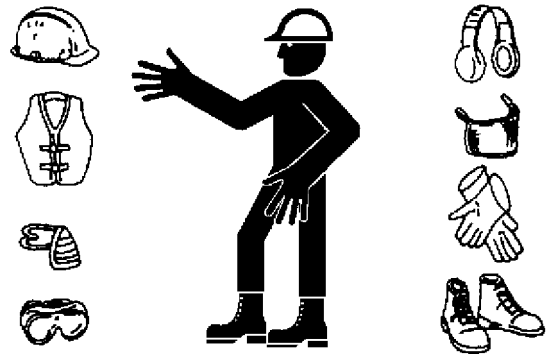

SA-438

Be sure to wear the correct equipment and clothing for the job. Do not take any chances.

- Avoid wearing loose clothing, jewelry, or other items that can catch on control levers or other parts of the machine.
- Operating equipment safely requires the full attention of the operator. Do not wear radio or music headphones while operating the machine.

SAFETY

Protect Against Noise

- Prolonged exposure to loud noise can cause impairment or loss of hearing.
- Wear a suitable hearing protective device such as earmuffs or earplugs to protect against objectionable or uncomfortably loud noises.



SA-434

Inspect Machine

- Inspect your machine carefully each day or shift by walking around it before you start it to avoid personal injury.
- In the walk-around inspection be sure to cover all points described in the "Inspect Machine Daily Before Starting" section in the operator's manual.



SA-435

SAFETY

General Precautions for Cab

- Before entering the cab, thoroughly remove all dirt and/or oil such as mud, grease, soil or stones that may mess up the cab from the soles of your work boots. If any controls such as a pedal is operated while with dirt and/or oil on the soles of the operator's work boots, the operator's foot may slip off the pedal, possibly resulting in a personal accident.
- Do not mess up around the operator's seat with parts, tools, soil, stones, obstacles that may fold up or turn over, cans or lunch box. The levers or pedals become inoperable if obstacle jams in operation stroke of the travel levers/pedals, pilot control shut-off lever or control levers, which may result in serious injury or death.
- Avoid storing transparent bottles in the cab. Do not attach any transparent type window decorations on the windowpanes as they may focus sunlight, possibly starting a fire.
- Refrain from listening to the radio, or using music headphones or mobile telephones in the cab while operating the machine.
- Keep all flammable objects and/or explosives away from the machine.
- After using the ashtray, always cover it to extinguish the match and/or tobacco.
- Do not leave cigarette lighters in the cab. When the temperature in the cab increases, the lighter may explode.
- Use proper floor mat dedicated to the machine. If another floor mat is used, it may be displaced and contact with the travel pedals during operation, resulting in serious injury or death.

SAFETY

Use Handholds and Steps

- Falling is one of the major causes of personal injury.
 - When you get on and off the machine, always face the machine and maintain a three-point contact with the steps and handrails.
 - Do not use any controls as hand-holds.
 - Never jump on or off the machine. Never mount or dismount a moving machine.
 - Be careful of slippery conditions on platforms, steps, and handrails when leaving the machine.
 - Never get on and off the machine with tools in your hands.

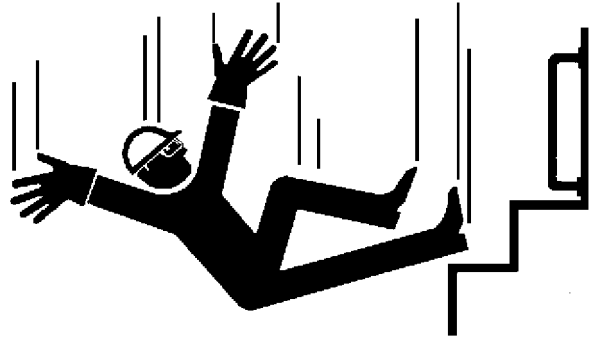

SA-439

Adjust the Operator's Seat

- A poorly adjusted seat for either the operator or for the work at hand may quickly fatigue the operator leading to misoperations.
 - The seat should be adjusted whenever changing the operator for the machine.
 - The operator should be able to fully depress the pedals and to correctly operate the control levers with his back against the seat back.
 - If not, move the seat forward or backward, and check again.
 - Adjust the rear view mirror position so that the best rear visibility is obtained from the operator's seat. If the mirror is broken, immediately replace it with a new one.



SA-378

SAFETY

Ensure Safety Before Rising from or Leaving Operator's Seat

- Before rising from the operator's seat to open/close either side window or to adjust the seat position, be sure to first lower the front attachment to the ground and then move the pilot control shut-off lever to the LOCK position. Failure to do so may allow the machine to unexpectedly move when a body part unintentionally comes in contact with a control lever and/or pedal, possibly resulting in serious personal injury or death.
- Before leaving the machine, be sure to first lower the front attachment to the ground and then move the pilot control shut-off lever to the LOCK position. Turn the key switch OFF to stop the engine.
- Before leaving the machine, close all windows, doors, and access covers and lock them up.

Fasten Your Seat Belt

- If the machine should overturn, the operator may become injured and/or thrown from the cab. Additionally the operator may be crushed by the overturning machine, resulting in serious injury or death.
 - Prior to operating the machine, thoroughly examine webbing, buckle and attaching hardware. If any item is damaged or worn, replace the seat belt or component before operating the machine.
 - Be sure to remain seated with the seat belt securely fastened at all times when the machine is in operation to minimize the chance of injury from an accident.
 - We recommend that the seat belt be replaced every three years regardless of its apparent condition.

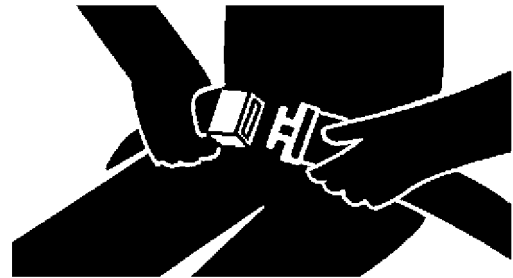

SA-237

SAFETY

Move and Operate Machine Safely

- Bystanders can be run over.
 - Take extra care not to run over bystanders. Confirm the location of bystanders before moving, swinging, or operating the machine.
 - Always keep the travel alarm and horn in working condition (if equipped). It warns people when the machine starts to move.
 - Use a signal person when moving, swinging, or operating the machine in congested areas. Coordinate hand signals before starting the machine.
 - Use appropriate illumination. Check that all lights are operable before operating the machine. If any faulty illumination is present, immediately repair it.
 - Ensure the cab door, windows, doors and covers are securely locked.
 - Check the mirrors and the monitor in the CAB for problems.
If there is, replace the problem part (s) or clean the mirror, camera and the monitor.
Refer to Rear View Monitor section on the cleaning of the camera and the monitor.

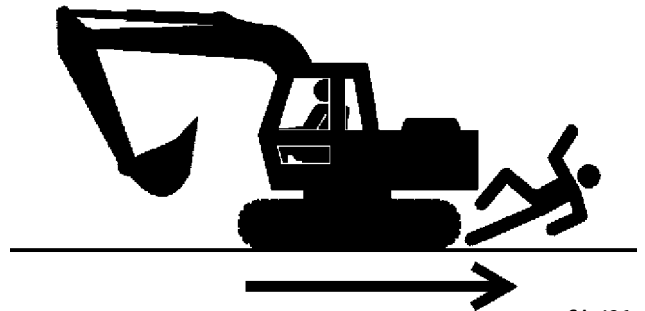

SA-426

Operate Only from Operator's Seat

- Inappropriate engine starting procedures may cause the machine to runaway, possibly resulting in serious injury or death.
 - Start the engine only when seated in the operator's seat.
 - NEVER start the engine while standing on the track or on ground.
 - Do not start engine by shorting across starter terminals.
 - Before starting the engine, confirm that all control levers are in neutral.
 - Before starting the engine, confirm the safety around the machine and sound the horn to alert bystanders.



SA-444

SAFETY

Jump Starting

- Battery gas can explode, resulting in serious injury.
 - If the engine must be jump started, be sure to follow the instructions shown in the “OPERATING THE ENGINE” chapter in the operator’s manual.
 - The operator must be in the operator’s seat so that the machine will be under control when the engine starts. Jump starting is a two-person operation.
 - Never use a frozen battery.
 - Failure to follow correct jump starting procedures could result in a battery explosion or a runaway machine.

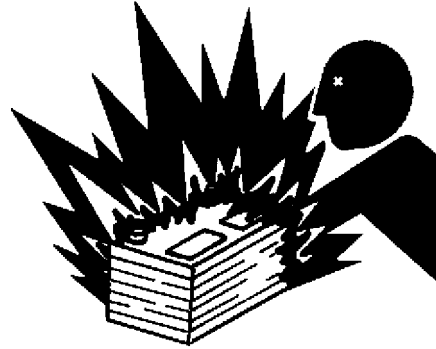

SA-032

Keep Riders off Machine

- Riders on machine are subject to injury such as being struck by foreign objects and being thrown off the machine.
 - Only the operator should be on the machine. Keep riders off.
 - Riders also obstruct the operator’s view, resulting in the machine being operated in an unsafe manner.



SA-379

SAFETY

Precautions for Operations

- Investigate the work site before starting operations.
 - Be sure to wear close fitting clothing and safety equipment appropriate for the job, such as a hard hat, etc. when operating the machine.
 - Clear all persons and obstacles from area of operation and machine movement.

Always beware of the surroundings while operating.

When working in a small area surrounded by obstacles, take care not to hit the upperstructure against obstacles.

- When loading onto trucks, bring the bucket over the truck beds from the rear side. Take care not to swing the bucket over the cab or over any person.

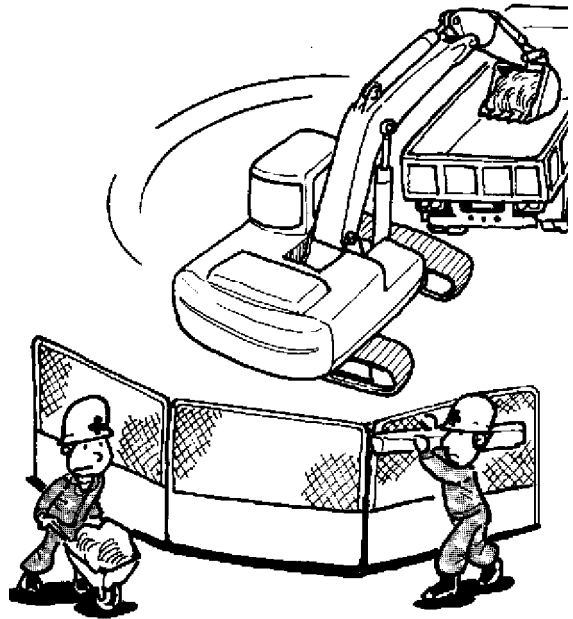

M178-05-007

SAFETY

Investigate Job Site Beforehand

- When working at the edge of an excavation or on a road shoulder, the machine could tip over, possibly resulting in serious injury or death.
 - Investigate the configuration and ground conditions of the job site beforehand to prevent the machine from falling and to prevent the ground, stockpiles or banks from collapsing.
 - Make a work plan. Use machines appropriate to the work and job site.
 - Reinforce ground, edges and road shoulders as necessary. Keep the machine well back from the edges of excavations and road shoulders.
 - When working on an incline or on a road shoulder, employ a signal person as required.
 - Confirm that your machine is equipped with a FOPS cab before working in areas where the possibility of falling stones or debris exist.
 - When the footing is weak, reinforce the ground before starting work.
 - When working on frozen ground, be extremely alert. As ambient temperatures rise, footing becomes loose and slippery.
 - Beware the possibility of fire when operating the machine near flammable objects such as dry grass.

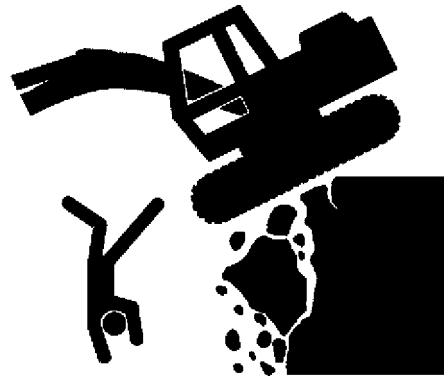

SA-380

SAFETY

- Make sure the worksite has sufficient strength to firmly support the machine.
When working close to an excavation or at road shoulders, operate the machine with the tracks positioned perpendicular to the cliff face with travel motors at the rear, so that the machine can more easily evacuate if the cliff face collapses.
- If working on the bottom of a cliff or a high bank is required, be sure to investigate the area first and confirm that no danger of the cliff or bank collapsing exists. If any possibility of cliff or bank collapsing exists, do not work on the area.
- Soft ground may collapse when operating the machine on it, possibly causing the machine to tip over. When working on soft ground is required, be sure to reinforce the ground first using large pieces of steel plates strong and firm enough to easily support the machine.
- Note that there is always a possibility of machine tipping over when working on rough terrain or on slopes. Prevent machine tipping over from occurring. When operating on rough terrain or on slopes:
 - Reduce the engine speed.
 - Select slow travel speed mode.
 - Operate the machine slowly and be cautious with machine movements.

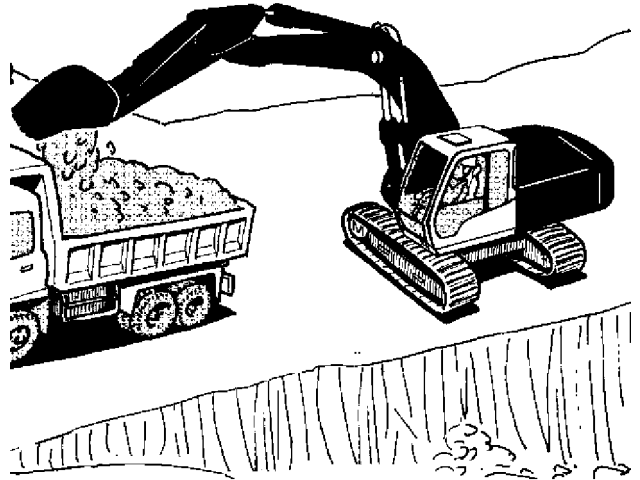

M104-05-016

Install OPG Guard

In case the machine is operated in areas where the possibilities of falling stones or debris exist, equip Hitachi OPG guard. Consult your authorized dealer for installing the OPG guard. The guard can be compliant with ROPS standards depending on the machine specifications.
In order not to impair operator protective structure:
Replace damaged ROPS or OPG guard. Never attempt to repair or modify the guard.

ROPS: Roll Over Protective Structure
OPG: Operator Protective Guard

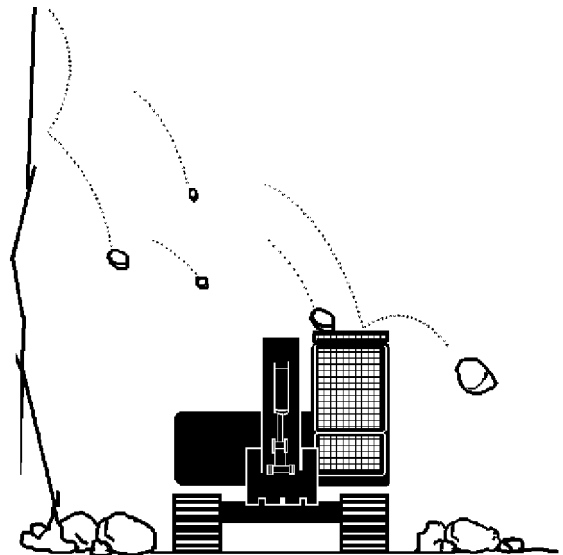

SA-490

SAFETY

Provide Signals for Jobs Involving Multiple Machines

- For jobs involving multiple machines, provide signals commonly known by all personnel involved. Also, appoint a signal person to coordinate the job site. Make sure that all personnel obey the signal person's directions.



SA-481

Confirm Direction of Machine to Be Driven

- Incorrect travel pedal/lever operation may result in serious injury or death.
 - Before driving the machine, confirm the position of the undercarriage in relation to the operator's position. If the travel motors are located in front of the cab, the machine will move in reverse when travel pedals/levers are operated to the front.

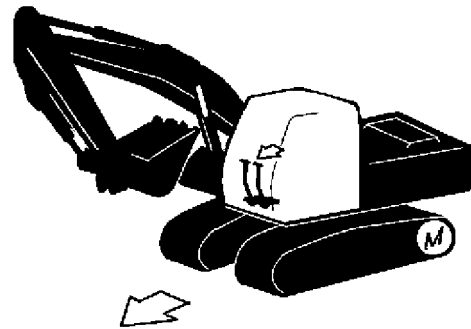

SA-491

Thank you so much for reading.
Please click the “Buy Now!”
button below to download the
complete manual.



After you pay.

You can download the most
perfect and complete manual in
the world immediately.

Our support email:

ebooklibonline@outlook.com