

RGP3152

[01G19]

KEY	PART NO.	PART NAME	QTY	Engine Serial No.	REMARKS
1	R71225	IMPELLER	1		
2	R71596	O-RING	1		
3	R98527	FILTER	1	348589-____	(WEEP HOLE)
4	RE69844	KIT	1		(SUB FOR RE12940, RE24772 OR RE55992)
5	R47153	O-RING	2		
6	R520580	GASKET	1		(SUB FOR R71315)
7	AR93518	SEAL	1	____-355878	(SUB RE39134)
7	RE39134	SEAL	1	355879-____	
8	JD10171	BALL BEARING	1	____-309262	(FRONT) (USE WITH R71224)
8	JD10363	BALL BEARING	1	309263-____	(FRONT) (USE WITH R83561)
9	SHAFT	1		(W/ R71224 - SUB RE69846)
9	SHAFT	1		(W/ R83561 - SUB RE69847)
10	JD10113	BALL BEARING	1	____-309262	(REAR) (USE WITH R71224)
10	JD10362	BALL BEARING	1	309263-____	(REAR) (USE WITH R83561)
11	R71361	GASKET	1		
12	KIT	1	____-309262	(USE WITH R71224) (SUB FOR RG19280) (SUB RE524397)
12	RE524397	KIT	1		(USE WITH R71224)
12	KIT	1	309263-____	(USE WITH R83561) (SUB RE524406)
12	RE524406	KIT	1		(USE WITH R83561)

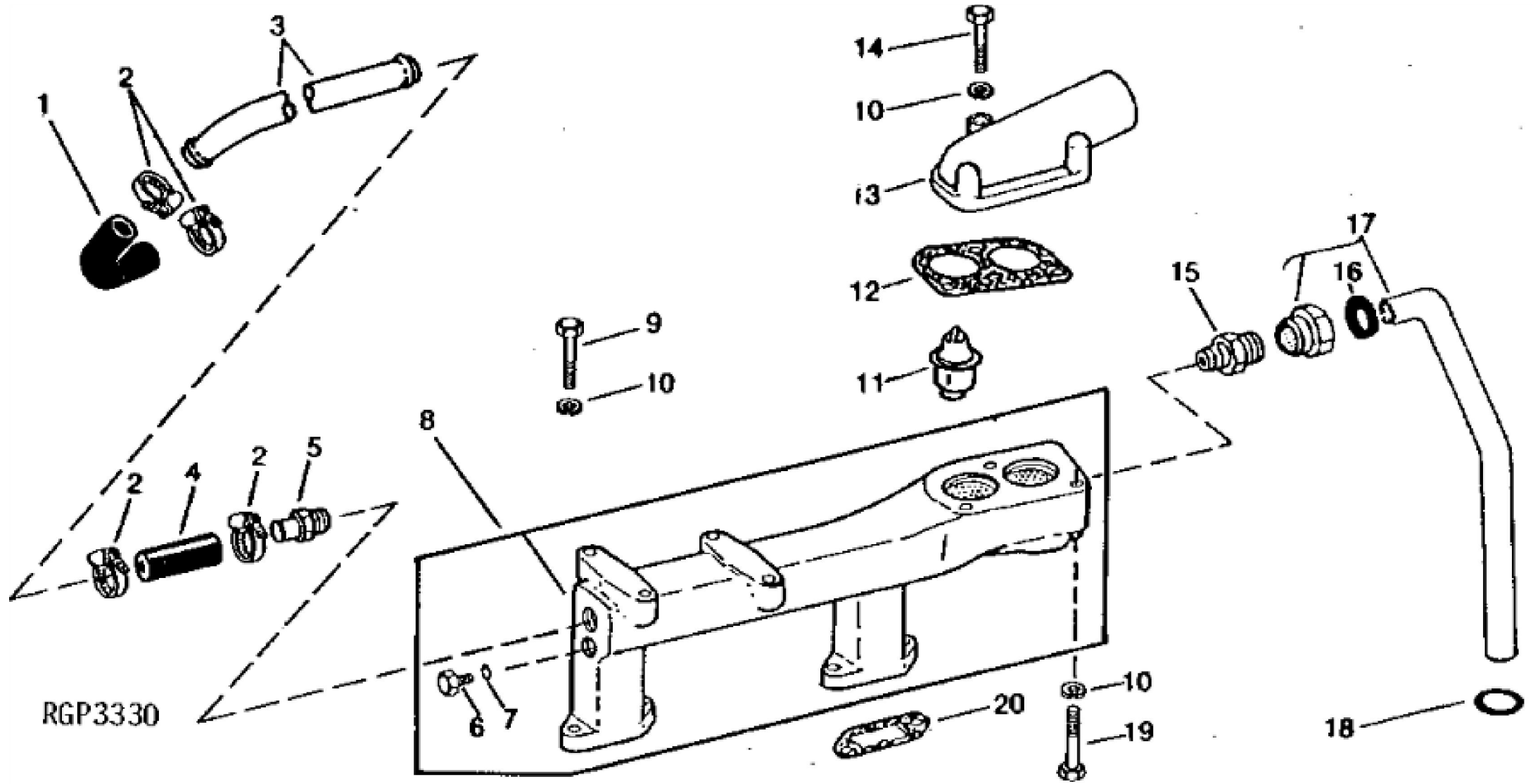

John Deere > Construction And Forestry > EXCAVATOR > 790D - EXCAVATOR > 790D Excavator and 793D Feller Buncher > 4 ENGINE 4 > THERMOSTATS, HOUSING AND WATER PIPING 0418 > 0418-2 - WATER OUTLET MANIFOLD AND THERMOSTATS (6466AT) [01G21]

KEY	PART NO.	PART NAME	QTY	REMARKS
1	R47430	HOSE	1	
2	TY22467	CLAMP	4	(SUB FOR AR21839)
3	R61128	LINE	1	
4	A5203R	HOSE	1	22 MM X 76 MM (7/8" X 3") (20R2)
5	R48362	ADAPTER FITTING	1	
6	R82719	FITTING PLUG	1	(SUB FOR R27094, APPL)
7	R26286	O-RING	1	
8	RE12848	MANIFOLD	1	(MARKED R78123 OR R50415) (SUB R78123, R26286 AND R82719)
8	R78123	MANIFOLD	1	(NOT AS SHOWN)
9	19H3219	CAP SCREW	4	3/8" X 1-3/8"
10	12H304	LOCK WASHER	7	3/8"
11	AR48675	THERMOSTAT	2	82°C (180°F) (770A,772A,770AH,772AH OR 793D)
11	AR48675	THERMOSTAT	1	82° (180°F) (790,792,790D,892D-LC)
11	R100671	PLUG	1	(EITHER OPENING) (USE WITH (1) AR48675) (790,792,790D,892D-LC)
12	R124607	GASKET	1	(SUB FOR R46479)
13	R58721	COVER	1	
14	19H1733	CAP SCREW	1	3/8" X 2-1/2"
15	R76560	COUPLING	1	
16	R76558	SLEEVE	1	
17	AR103815	OIL LINE	1	
18	R47153	O-RING	1	
19	19H2128	CAP SCREW	2	3/8" X 3"
20	R88397	GASKET	2	(SUB FOR R42693)

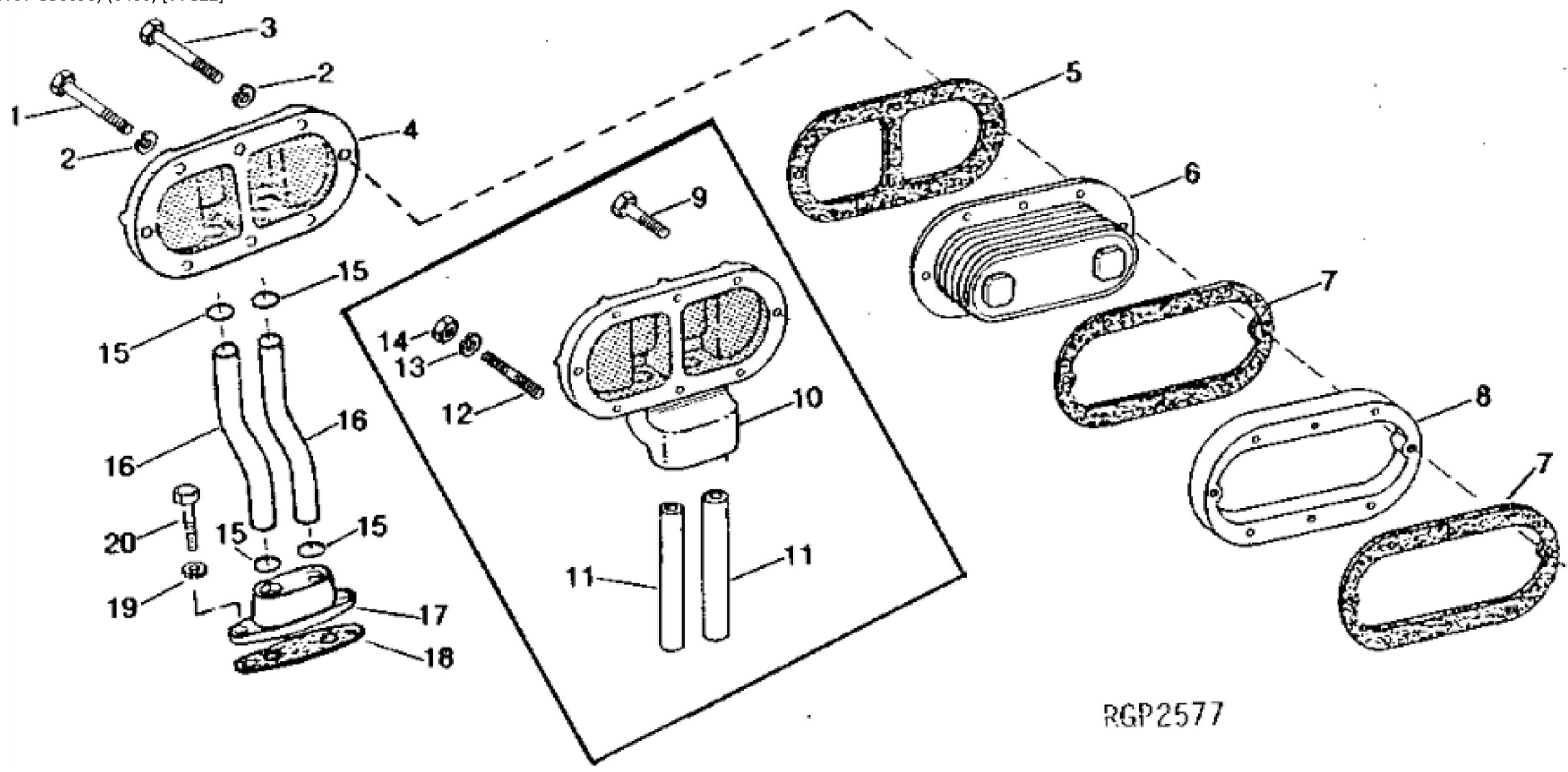

RGP2577

KEY	PART NO.	PART NAME	QTY	Engine Serial No.	REMARKS
1	19H1921	CAP SCREW	1	310363-____	5/16" X 3-1/4"
1	19H1897	CAP SCREW	1		5/16" X 3-3/4" (NOT USED IN U.S. AND CANADA)
2	12H303	LOCK WASHER	8		5/16"
3	19H1949	CAP SCREW	7	310363-____	5/16" X 2-1/2"
4	R51283	COVER	1	310363-____	
5	R50419	GASKET	1		
6	AT25038	OIL COOLER	1		
7	AR58952	GASKET	2		
8	R50418	SPACER	1		
9	19H1907	CAP SCREW	5	____-127033	5/16" X 2-3/4"
9	19H1907	CAP SCREW	7	127034-310362	5/16" X 2-3/4"
9	19H1921	CAP SCREW	1	____-310362	5/16" X 3-1/4"
9	19H2852	CAP SCREW	1		5/16" X 4" (USE WITH HEATER CLAMP)
10	R50421	COVER	1	____-310362	
11	R50422	OIL TUBE	2	____-310362	
12	R50375	STUD	2	____-127033	
13	12H303	LOCK WASHER	2	____-127033	5/16"
14	14H785	NUT	2	____-127033	5/16"
15	R47153	O-RING	4		(SUB FOR R50420, APPL)
16	R83545	TUBE	2	310363-____	
17	R50423	ADAPTER FITTING	1		
18	R50424	GASKET	1		
19	12H304	LOCK WASHER	2		3/8", (NO LONGER REQUIRED)
20	19H3483	CAP SCREW	2		3/8" X 1-1/8"

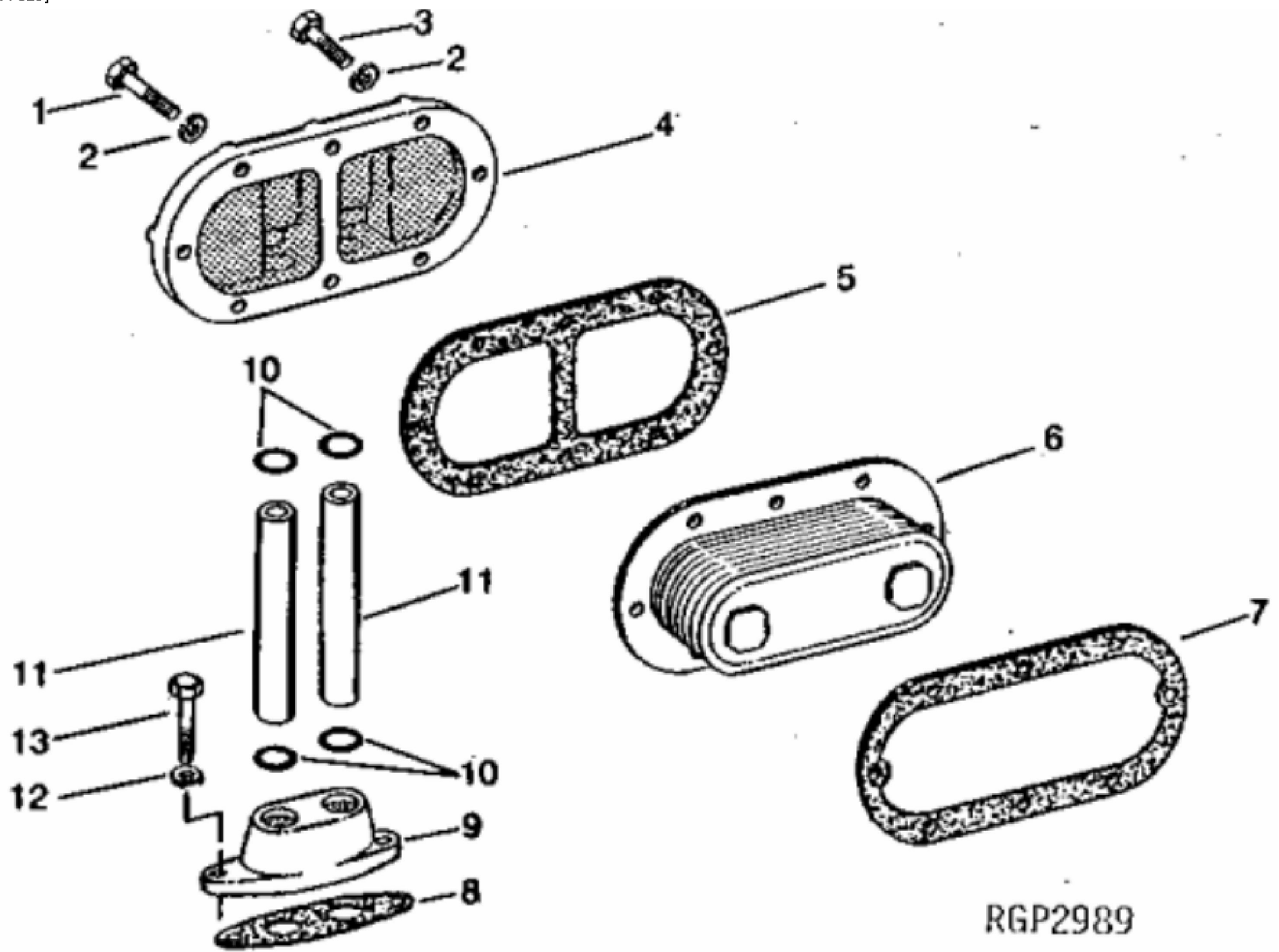

RGP2989

Thank you so much for reading.
Please click the “Buy Now!”
button below to download the
complete manual.



After you pay.

You can download the most
perfect and complete manual in
the world immediately.

Our support email:

ebooklibonline@outlook.com