

ETN96755C

KEY	PART NO.	PART NAME	QTY	REMARKS	
1	SJ15445	COVER	1	SUB FOR SJ316921	
2	SJ316924	SCREEN	1		
3	SU316920	GASKET	1		
4	SJ16954	STRAP	1		
5	SU316923	GASKET	1		
6	SJ316922	STRAP	1		
7	SJ16953	BRACKET	1		
8	14M7147	NUT	8	M8	
9	SU36125	BOLT	5		
10	SU30510	ISOLATOR	2		
11	SJ319927	FUEL TANK	1		
12	SU318990	LOCK WASHER	4		
13	SU328908	WASHER	1		
14	SJ316918	FUEL TANK	1		
15	19M7139	CAP SCREW	4	M8 X 20	
16	SU30511	ISOLATOR	2		
17	19M7386	CAP SCREW	1	M12 X 20	
18	SJ16931	BRACKET	1		

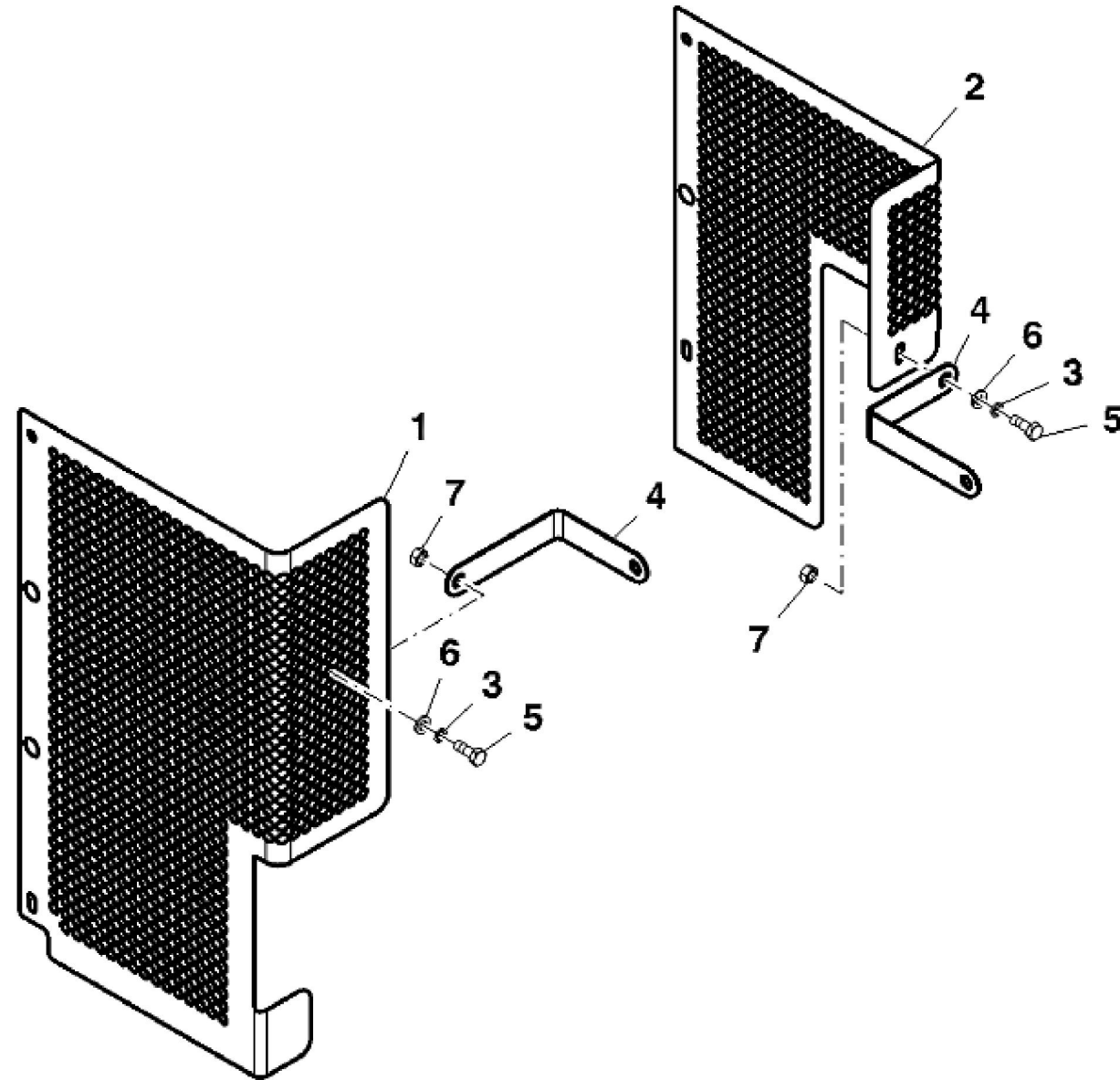

ETN17517A

KEY	PART NO.	PART NAME	QTY	REMARKS	
1	SU327152	SHIELD	1	LH	
2	SU327153	SHIELD	1	RH	
3	SU318989	LOCK WASHER	2		
4	SU324056	BRACKET	2		
5	19M7560	CAP SCREW	2	M6 X 16	
6	24M7054	WASHER	2	6.400 X 12 X 1.600 mm	
7	14M7567	NUT	2	M6	

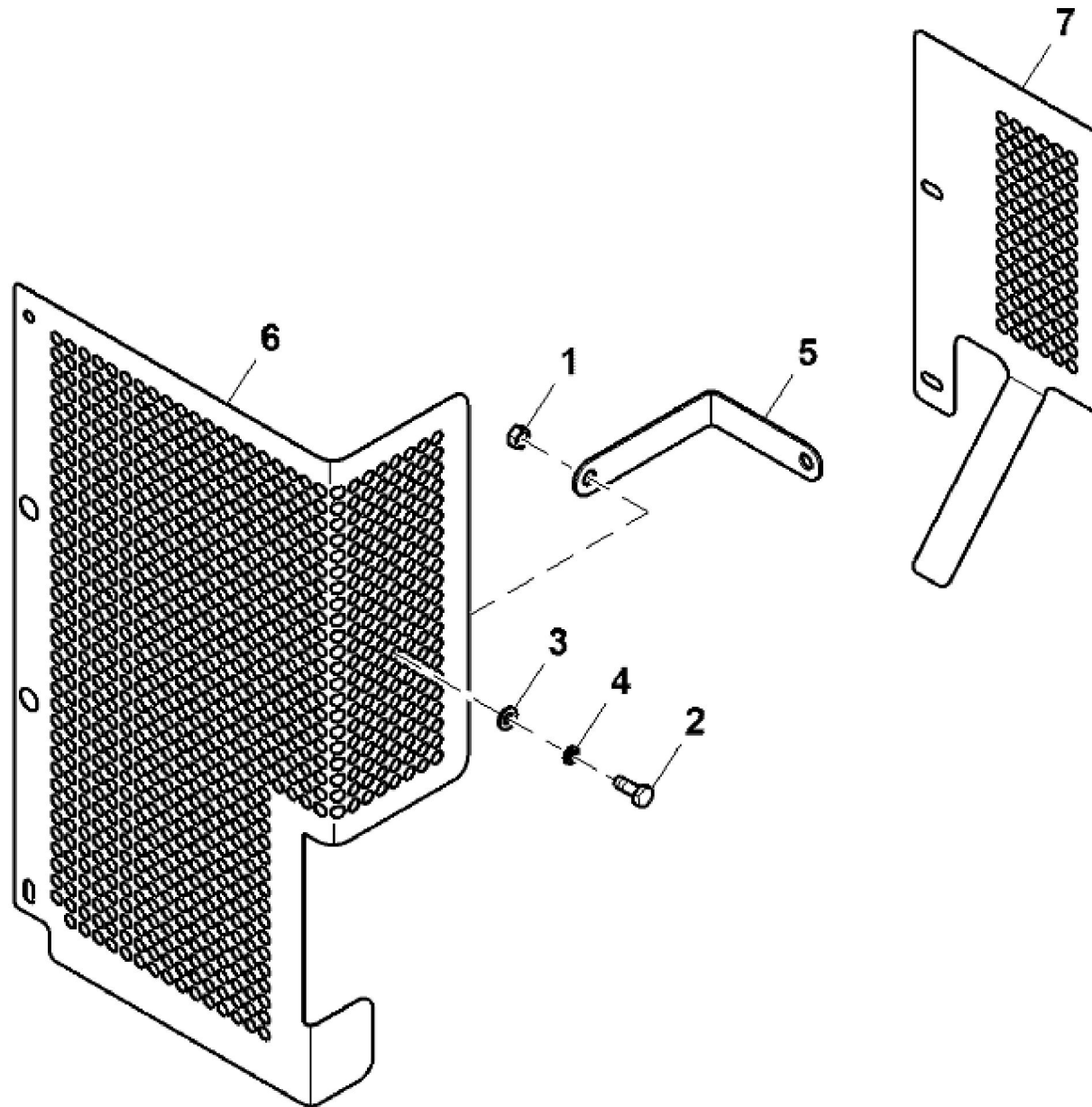

ETN17517D

KEY	PART NO.	PART NAME	QTY	REMARKS	
1	14M7567	NUT	1	M6	
2	19M7560	CAP SCREW	1	M6 X 16	
3	24M7054	WASHER	1	6.400 X 12 X 1.600 mm	
4	SU318989	LOCK WASHER	1		
5	SU324056	BRACKET	1		
6	SU327152	SHIELD	1	LH	
7	SU42967	SHIELD	1	RH	

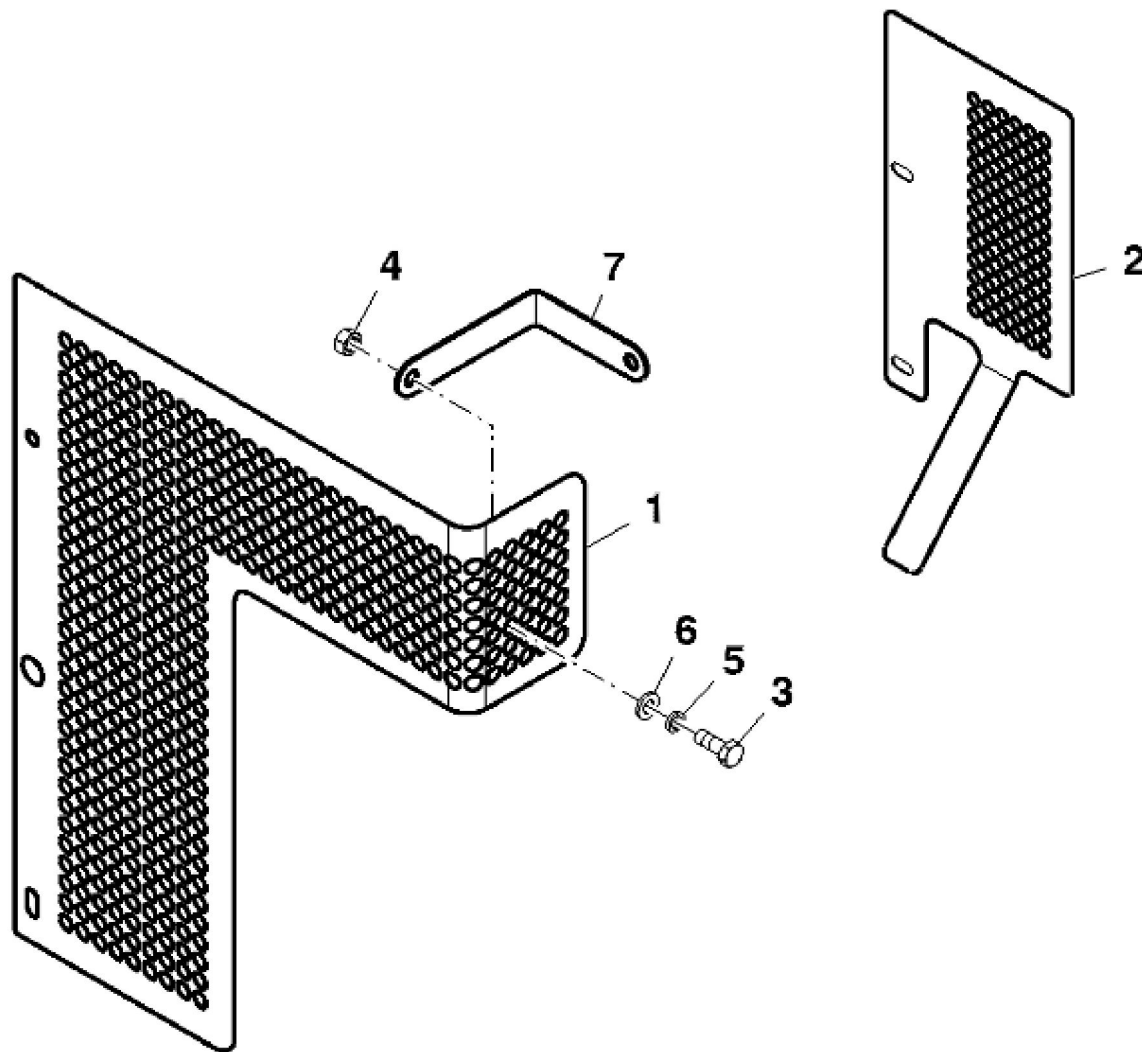

ETN17903B

Thank you so much for reading.  
Please click the “Buy Now!”  
button below to download the  
complete manual.



After you pay.

You can download the most  
perfect and complete manual in  
the world immediately.

Our support email:

[ebooklibonline@outlook.com](mailto:ebooklibonline@outlook.com)