

Section: ENGINE
CRANKCASE

Fig.	P/n	QTY	Name
Notes:			
[ANTARES 110]			
0	0.336.0050.6/10	1	gasket set
1	0.007.0779.6	1	crankcase 1216 <- PER ANTARES 110 - 1147 <- PER ANTARES 130
1	0.007.0779.6/10	1	crankcase -> 1217 X ANTARES 110 -> 1148 X ANTARES 130
2	2.3130.001.1	1	plug 1/8" gas
3	2.3130.002.1	2	plug 1/4" gas
4	2.3130.003.1	7	plug 3/8" gas
5	2.3131.006.0	1	plug m 22 x 1.5
6	2.1324.011.0	1	plug
7	0.065.1140.0	6	special bushing 59X55X20
8	0.065.1141.0	1	special bushing 59X55X30
9	0.066.1151.0	1	pin
10	2.3179.012.0	1	plug 60
11	0.065.1117.0	14	screw m 12 x 100
12	0.065.1114.0/10	5	support
13	0.065.1112.7/10	1	support
14	2.1699.165.0	1	bush 12.3x15x16
15	0.007.0848.3/20	1	support -> 1217 X ANTARES 110 -> 1148 X ANTARES 130
15	0.065.1116.3/10	1	- 1216 <- X ANTARES 110 - 1147 <- X ANTARES 130
16	2.1699.165.0	1	bush 12.3x15x16
17	2.3199.092.0	1	plug 8 x 12
18	0.066.1152.0/10	4	gasket
19	2.0432.003.7	18	stud bolt m 8 p.1.25 / p.1 x 20
20	2.1539.064.0	6	special oil seal 120.33x2.62 1521 <- X ANTARES 110 - 1520 <- X ANTARES 130
20	2.1539.130.0/10	6	special oil seal 117.07x3.53 -> 1522 X ANTARES 110-> 1521 X ANTARES 130
21	2.1532.072.0	1	oil seal 26.70x1.78
22	2.3199.405.2	1	plug m 28 p.1.5
23	2.1560.017.0	1	gasket 22.2 x 27
24	2.3120.002.4	1	plug m 22 x 1.5
25	0.007.0805.0/40	1	flange -> 1463 X ANTARES 110 -> 1440 X ANTARES 130
25	0.007.1655.0	1	flange 1462 <- X ANTARES 110 - 1439 <- X ANTARES 130
26	2.0112.511.2	8	screw m 14 p.2 x 30
27	2.1651.912.0	2	cylindrical plug 12x28

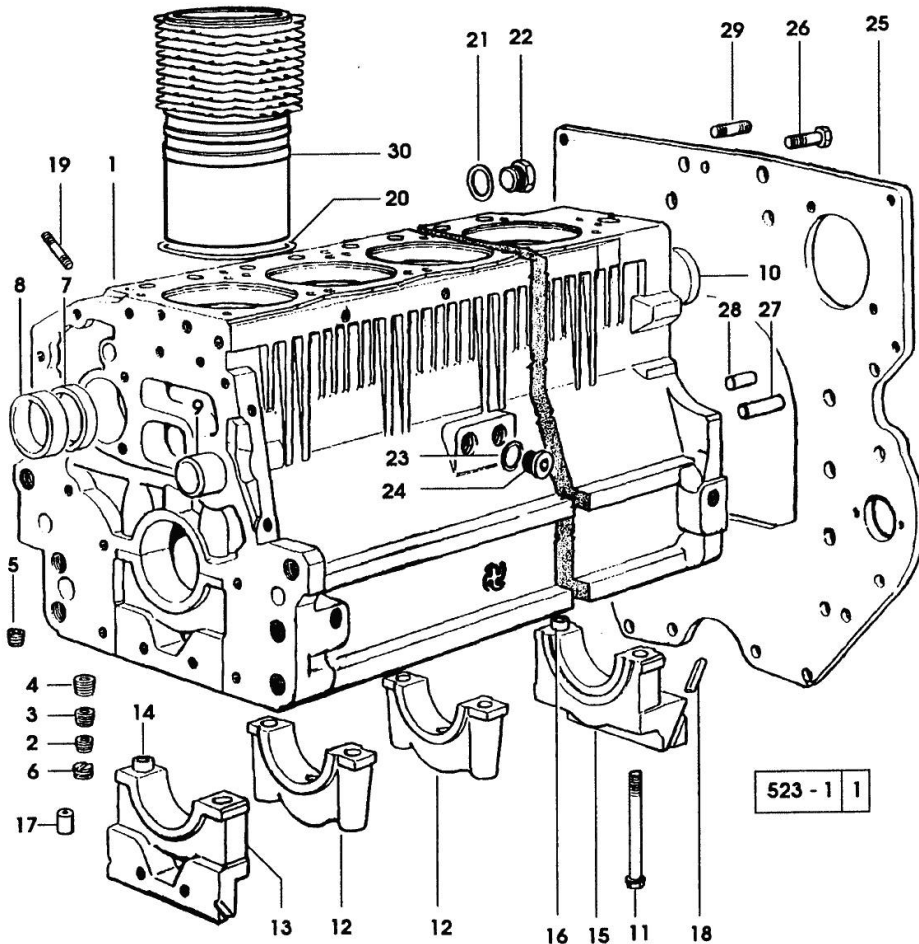

Section: ENGINE
CRANKCASE

Fig.	P/n	QTY	Name
28	2.1651.917.0	1	cylindrical plug 12x40
29	2.0432.255.7	2	stud bolt m 12 p.1.75-1.25x25
30	0.B13.0355.0	6	engine cylinder "B"

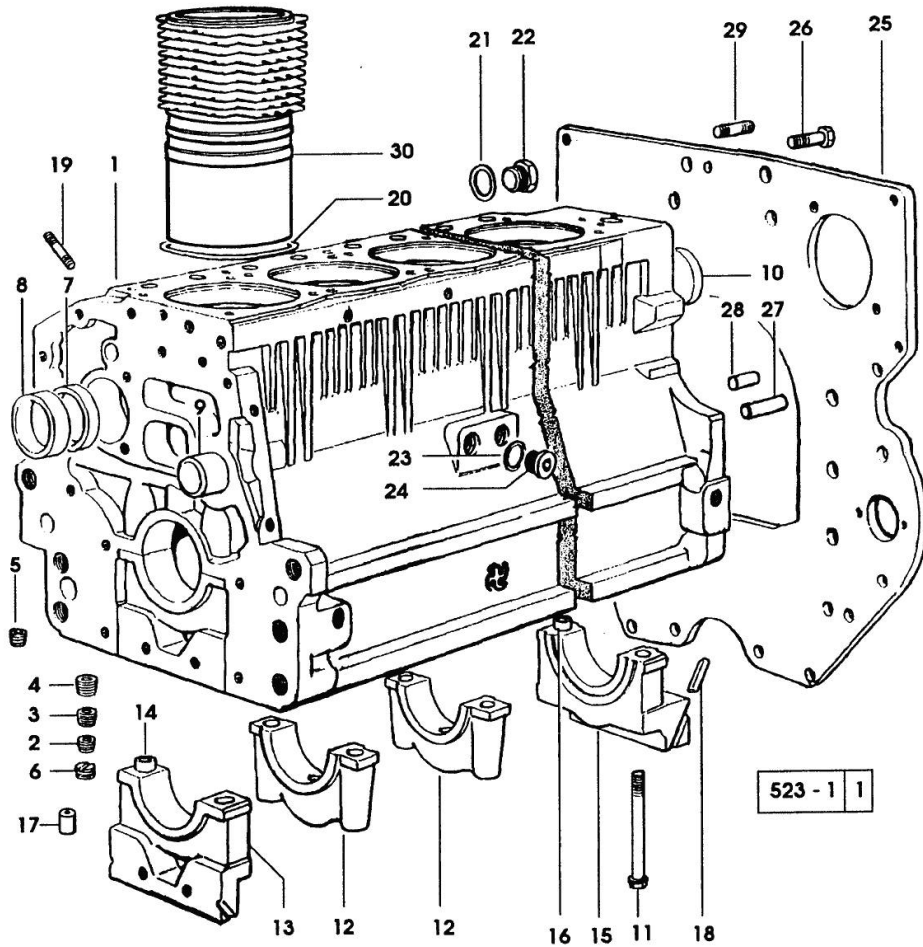

Section: ENGINE
TIMING CASE

Fig.	P/n	QTY	Name
------	-----	-----	------

Notes:
[ANTARES 110]

1	0.065.1132.0/20	1	guard
2	0.065.1150.0/30	1	gasket
3	0.065.1152.0	1	gasket
4	0.065.1151.0	1	cover
5	2.1470.004.2	4	lock washer 8
6	2.0112.205.2	2	screw m 8 p.1.25 x 16
7	2.0432.003.7	2	stud bolt m 8 p.1.25 / p.1 x 20
8	2.1011.405.2	2	nut m 8 p.1
9	2.0312.214.2	3	screw m 8 p.1.25 x 40
10	2.1480.014.1	15	washer 8
11	2.0432.003.7	2	stud bolt m 8 p.1.25 / p.1 x 20
13	2.0312.208.2	8	screw m 8 p.1.25 x 25
13	2.0312.219.2	4	screw m 8 p.1.25x65
14	2.1529.167.0	1	oil seal

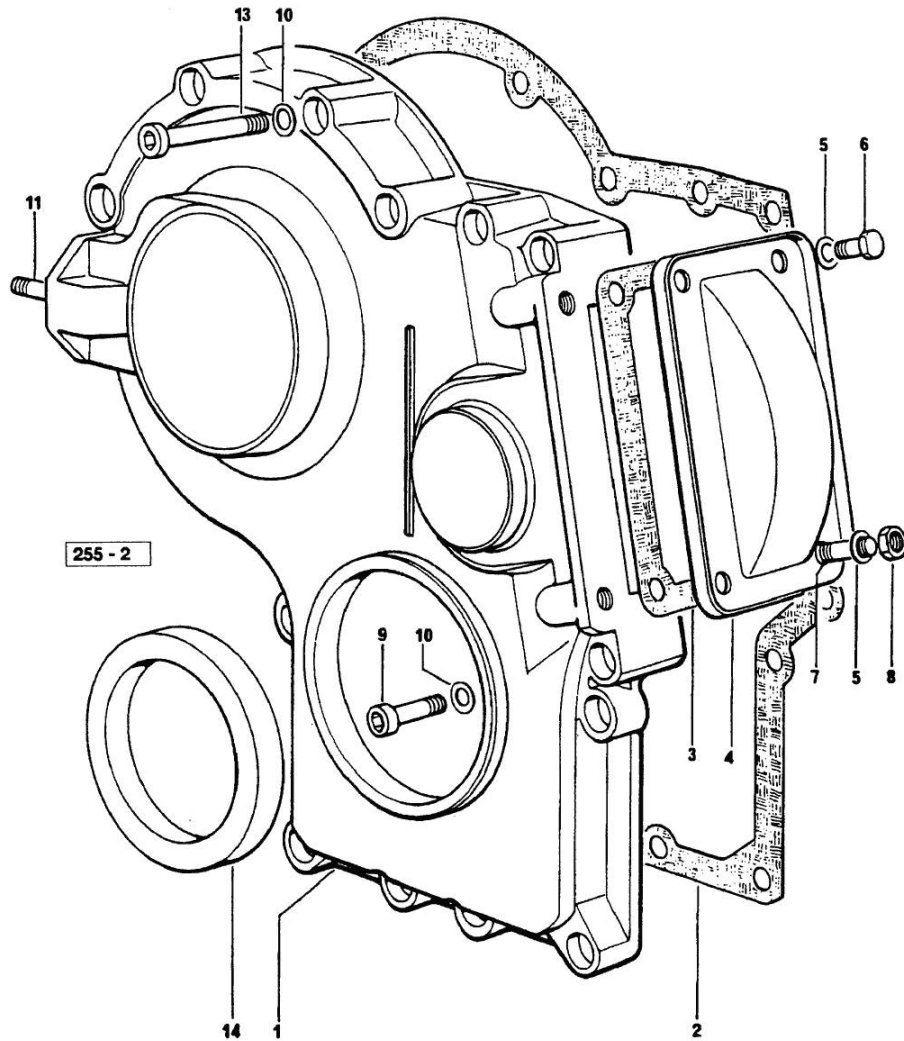

Section: ENGINE

CRANKSHAFT

Fig.	P/n	QTY	Name
------	-----	-----	------

Notes:
[ANTARES 110]

1	0.006.5605.3	1	crankshaft 1216 <-
1	0.006.5605.3/30	1	crankshaft -> 1217
1	0.007.0855.0/10	1	gear -> 1217
2	2.1651.915.0	1	pin 12x35
3	0.065.1215.0/10	7	main half bushing STANDARD
3	0.065.1215.7	7	main half bushing - mm 0.25
3	0.065.1215.8	7	main half bushing - mm 0.50
4	0.065.1216.0/10	7	main half bushing STANDARD
4	0.065.1216.7	7	main half bushing - mm 0.25
4	0.065.1216.8	7	main half bushing - mm 0.50
5	0.065.1218.0	4	shim STANDARD
5	0.065.1218.7	4	shim + mm 0.10
5	0.065.1218.8	4	shim + mm 0.15
6	2.1599.524.7	1	washer 21x60x12
7	2.1720.006.0	1	key 4x6.5
8	0.009.3704.3	1	antivibration pulley
9	0.065.1254.0/20	1	gasket
10	0.007.0851.0/10	1	cover -> 1217
10	0.065.1253.0/20	1	cover 1216 <-
11	2.1529.073.0	1	special oil seal 110x130x13
12	2.1474.009.2	9	spring washer 8
13	2.0112.207.2	9	screw m 8 p 1.25 x 20
14	0.008.4049.3	1	flywheel mm 373
14	0.065.1242.0	1	crown wheel Z = 123
15	0.288.3625.0	1	flange
16	2.0139.023.2	6	screw
17	0.008.2212.0/60	1	pulley
18	2.1589.136.0	2	shoulder ring 71x110x0.5
18	2.1589.137.0	2	shoulder ring 71x110x1
19	2.1470.006.2	6	lock washer 10
20	2.0112.322.2	6	screw m 10 p.1.5x65
21	0.078.1220.3/30	6	engine connecting rod
22	2.0399.213.0	2	screw m 12 p.1.25x61.5
23	2.1559.114.0/10	1	special bushing
24	0.065.1225.0	12	con.rod half bushing STANDARD - A = 28.75 -> 29.00
24	0.065.1225.7	12	con.rod half bushing - mm 0.25

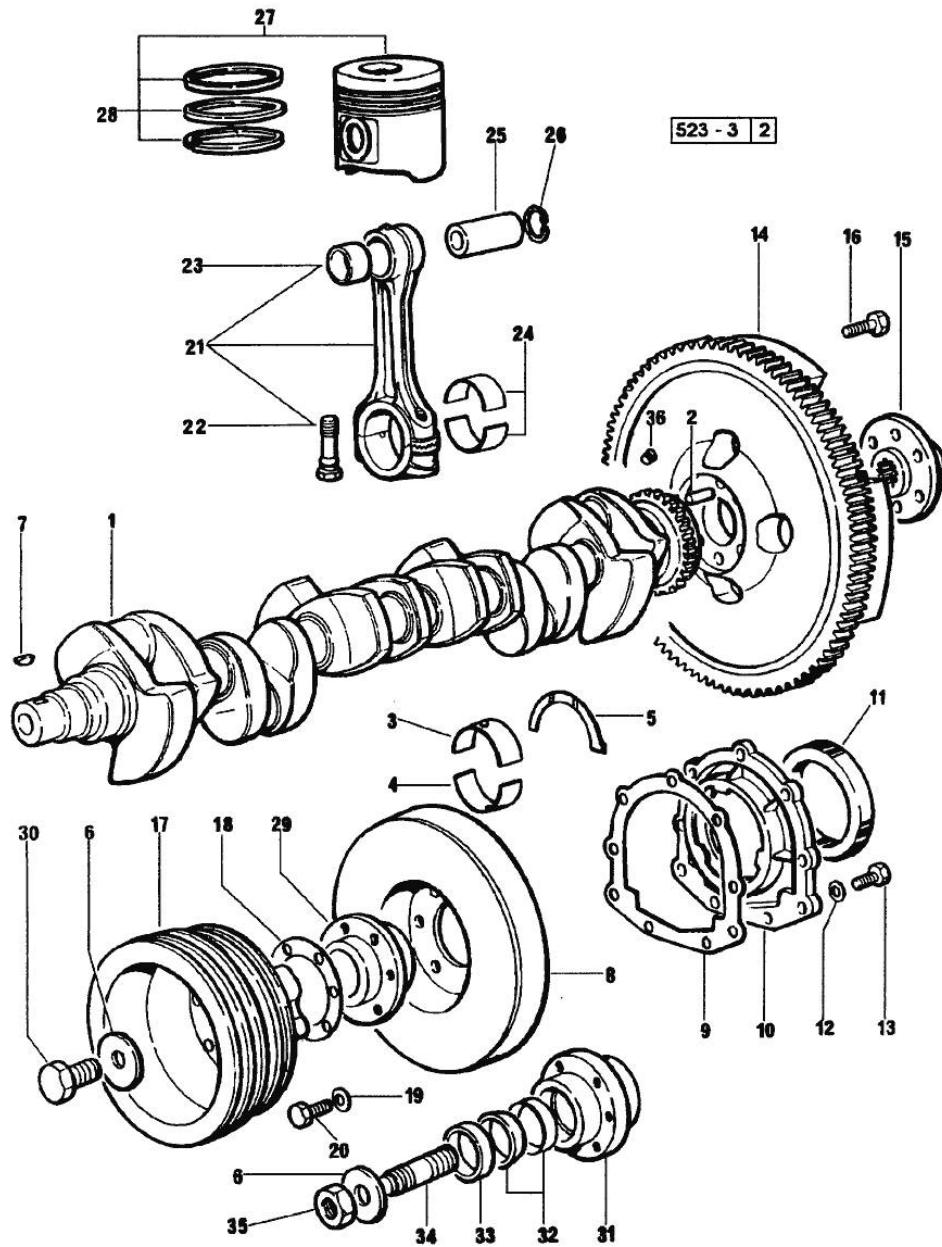

CRANKSHAFT

Fig.	P/n	QTY	Name
25	0.078.1236.0	6	piston pin Ø 18 / Ø 35 / L = mm 86
26	2.1411.014.1	12	circlip 35
27	0.086.0060.A	6	complete piston "A"
28	0.086.0052.6/10	6	piston ring set
29	0.007.0896.0/20	1	hub 1216 <-
29	0.007.1187.0	1	hub -> 1217
30	2.0399.144.7/10	1	screw m 20 p.1.5x51
31	0.011.2141.0/10	1	hub -> 1217 FOR FRONT PTO
31	0.011.3510.0/10	1	hub 1216 <- FOR FRONT PTO
32	0.035.1263.0	2	ring -> 1217
32	0.065.1256.0	2	ring 45x52 1216 <-
33	2.1579.865.0	1	spacer 45.2x51.8x10 1216 <-
33	2.1579.949.0	1	ring 50.2x56.8x8 -> 1217
34	2.0439.195.7	1	stud bolt m 20 p.1.5x80
35	2.1019.094.7	1	nut m 20 p.1.5
36	2.3130.001.1	6	plug 1/8" gas

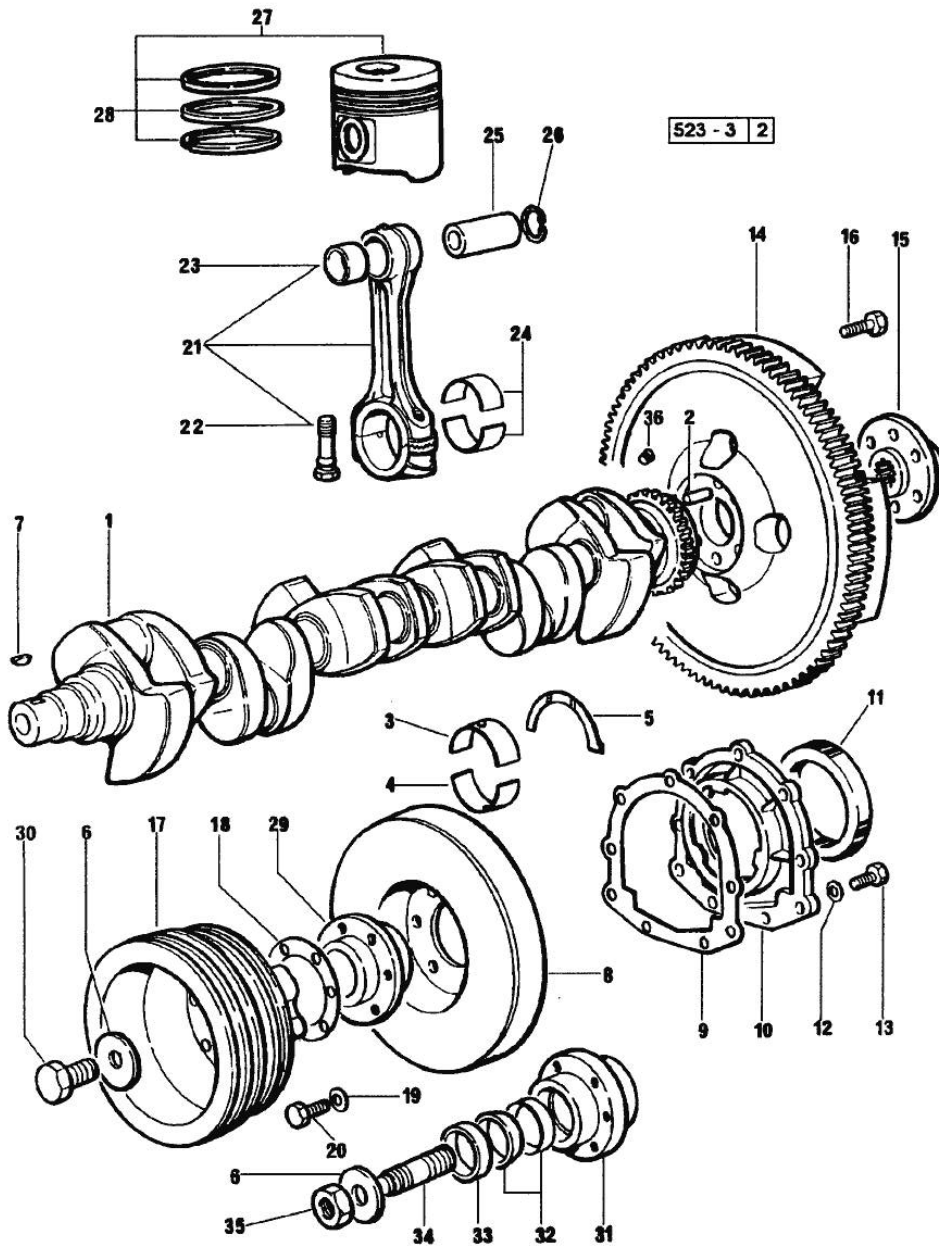

Section: ENGINE

CAMSHAFT

Fig.	P/n	QTY	Name
------	-----	-----	------

Notes:
[ANTARES 110]

1	0.065.1324.0/10	1	gear Z = 32
1	0.075.1310.3/30	1	camshaft
2	0.065.1353.0	1	small plate
3	2.0312.206.2	2	screw m 8 p 1.25 x 20
4	2.1480.014.1	2	washer 8
5	0.007.1188.0/30	1	gear Z = 29
			-> 1217 X ANTARES 110 -> 1148 X ANTARES 130
5	0.065.1323.0/30	1	gear Z = 29
			1216 <- X ANTARES 110 - 1147 <- X ANTARES 130
6	0.007.1177.3/20	1	gear z = 57
7	0.065.1351.0	2	shoulder ring
8	0.065.1352.0	1	shim
9	2.1410.016.1	1	circlip 40
10	0.013.5017.0	1	gear z=58
11	0.065.1350.0	1	small disc
12	2.0132.207.2	4	screw m 10 p.1 x 25
13	0.065.1330.0	12	tappets
14	2.1569.114.0/10	24	gasket 14x18.5x8
15	2.1599.437.0	12	shoulder ring
16	2.4019.300.1/10	12	spring 18.5x52x2
17	0.065.1332.0	12	sleeve
18	0.065.1331.2	12	rod

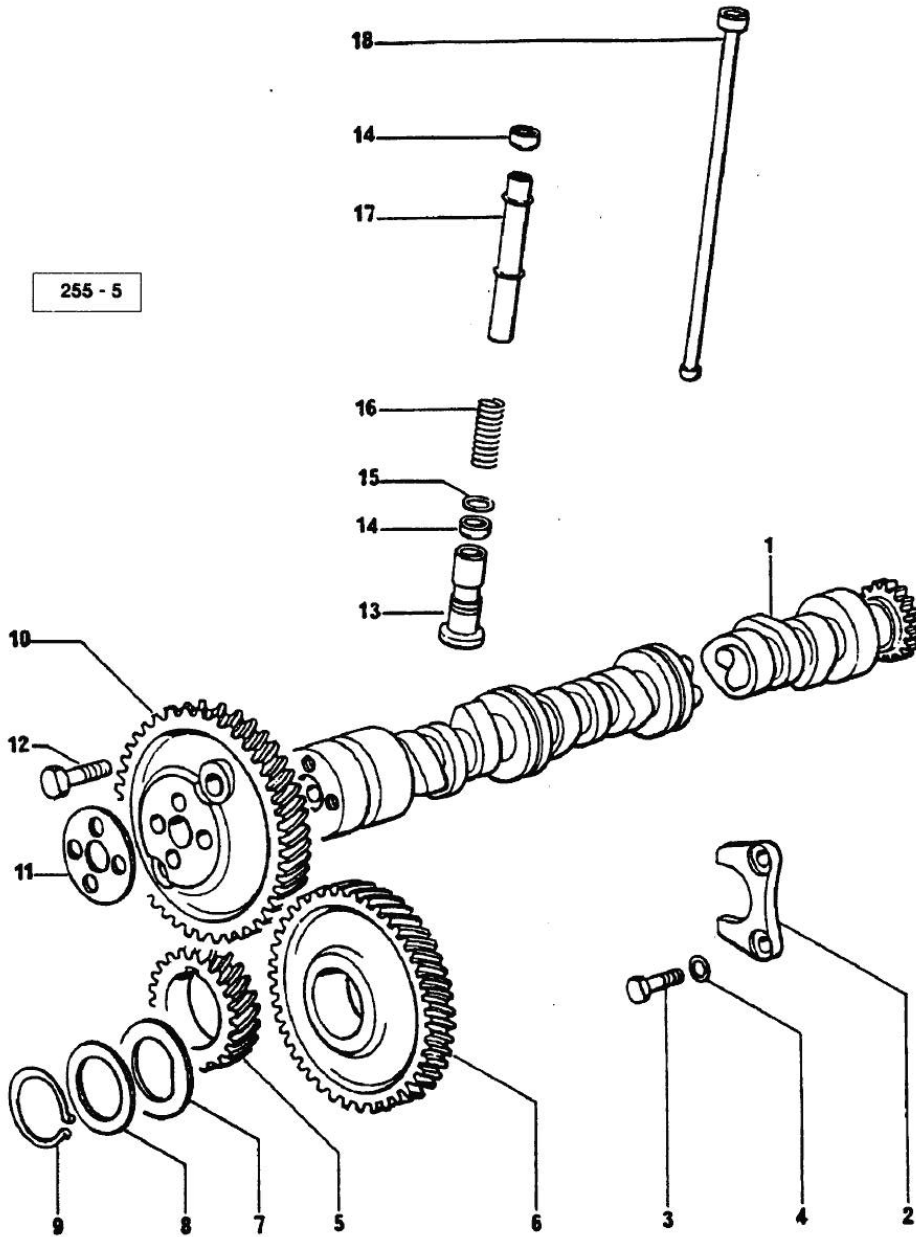

Section: ENGINE
CYLINDER HEAD

Fig.	P/n	QTY	Name
------	-----	-----	------

Notes:
[ANTARES 110]

0	0.336.0057.6	1	gasket set
1	0.066.1432.3	12	rocker arm
2	2.1559.021.0/40	12	bushing 15x19x22
3	2.1011.405.2	12	nut m 8 p.1
4	0.021.1434.0	12	screw
5	2.1011.421.2	12	nut m 10 p.1.25
6	2.0432.163.7	12	stud bolt m 10 p.1.5 / p.1.25 x 45
7	0.066.1430.0/10	6	support
8	0.066.1431.0	6	pin
9	0.078.1450.3	1	cover
10	2.1410.055.7	12	circlip 19
11	0.010.6016.0	6	inlet valve mm 43.63 / Ø mm 9
12	2.1599.432.0	12	shoulder ring
13	0.074.1423.0	12	conical valve cotter
14	0.066.1425.0	12	cup
15	2.4019.287.0	12	spring
16	0.007.1122.0/10	6	bush L = mm 6.4 (...) <-
16	0.065.1413.0/10	6	bush L = mm 97.1 (...) <-
17	2.0432.161.7	6	stud bolt m 10 p.1.5 / p.1.25 x 40
18	0.065.1443.0/20	24	screw
19	0.007.1110.3/60	6	engine head
20	0.007.1779.0/20	12	valve guide
21	0.066.1427.0	6	valve seat
22	0.078.1426.0	6	valve seat
23	0.085.1450.0/10	6	head gasket mm 0.50
23	0.085.1451.0/10	6	head gasket mm 0.7
23	0.085.1452.0/10	6	head gasket mm 1.0
23	0.085.1453.0/10	6	head gasket mm 0.8
24	0.078.1440.3	1	cover
24	2.3171.008.4	1	plug 20
25	0.009.3877.0/10	2	tappet gasket
26	2.0399.130.2	6	screw m 8 x 30
27	2.1532.035.0	6	oil seal 14x1.78
28	2.6859.091.0	2	clamp
29	0.075.1452.0/10	1	sleeve
30	0.066.1421.0	6	exhaust valve

Section: ENGINE
LUBRICATION 1216 <=>

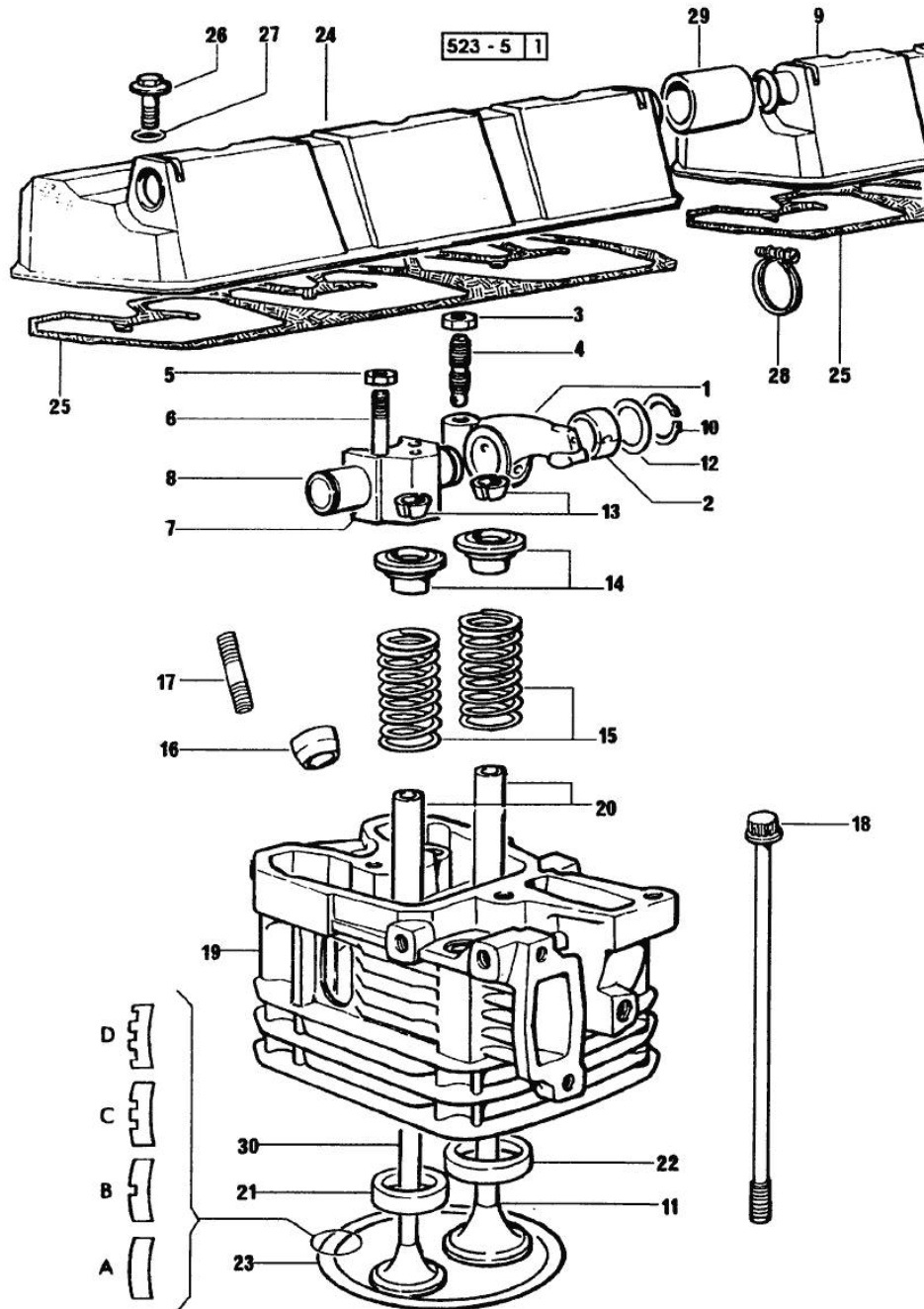
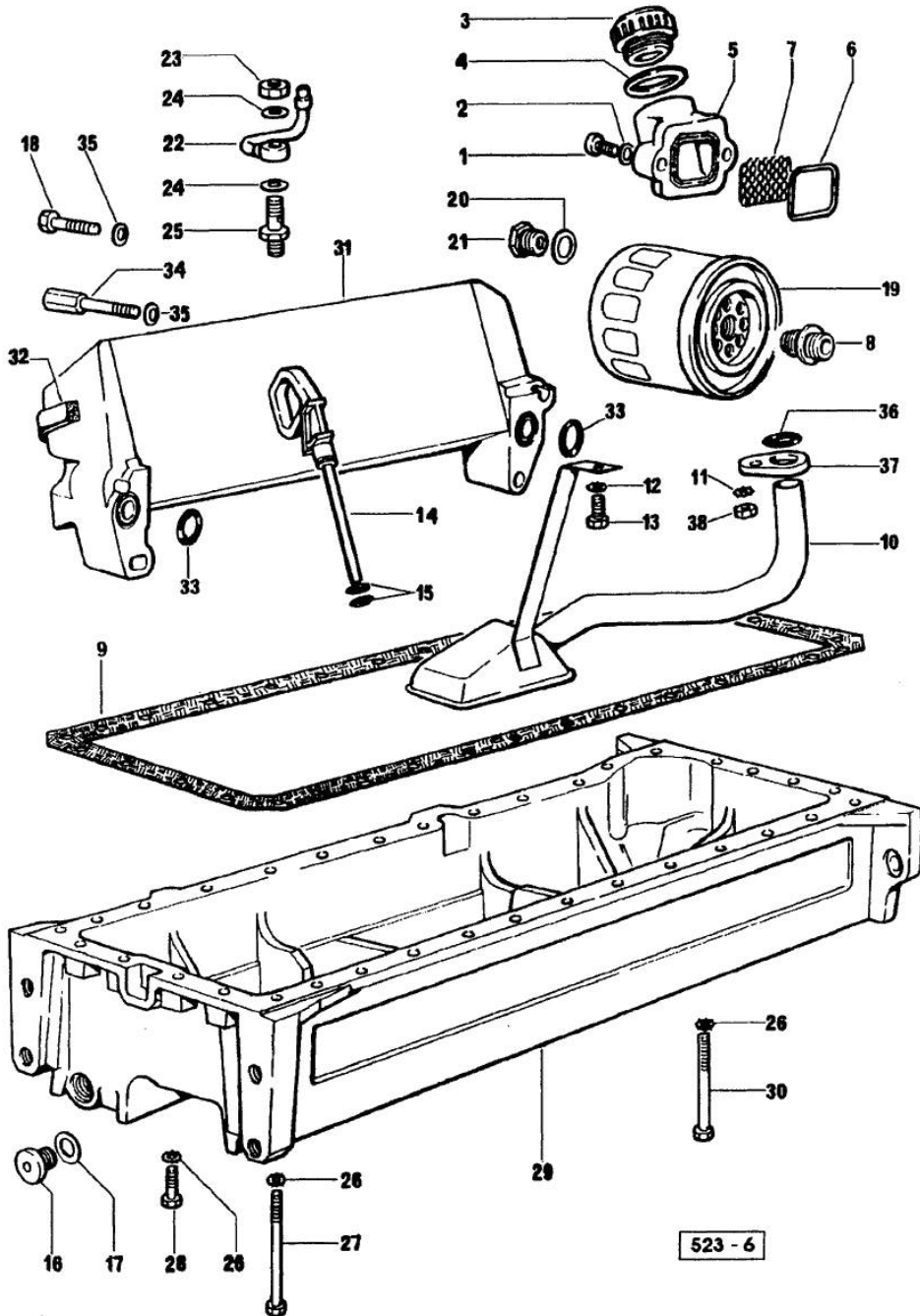

Fig.	P/n	QTY	Name
------	-----	-----	------

Notes:
 [ANTARES 110]

1	2.0312.206.2	2	screw m 8 p 1.25 x 20
2	2.1480.014.1	2	washer 8
3	0.041.1135.4	1	plug 1" gas
4	2.1569.072.0	1	gasket 32 x 39.5 x 2
5	0.065.1565.0/10	1	pipe union
6	2.1539.042.0	1	special oil seal 47.35x1.78
7	0.065.1567.0/10	1	filter
8	2.3339.307.0	2	pipe fitting m 22 p.1.5-3/4"
9	0.075.1512.0	1	gasket
10	0.007.0880.3	1	tube
11	2.1470.004.2	1	lock washer 8
12	2.1470.004.2	1	lock washer 8
13	2.0112.205.2	1	screw m 8 p.1.25 x 16
14	0.080.1513.2/10	1	dipstick
15	2.1539.065.0	2	special oil seal 8.73 x 1.78
16	2.3199.001.2	1	plug 1/2" gas
17	2.1560.054.0	1	gasket 21 x 26
18	2.0112.211.2	2	screw m 8 p.1.25 x 30
19	0.044.1567.0	2	oil filter element
20	2.1560.014.0	1	washer 18.2 x 24
21	2.3339.353.2/20	1	pipe fitting 12 p.1.5-18 p.1.5
22	0.086.1550.2	6	sprayer nozzle
23	2.1099.108.2	6	special nut m 10 p.1
24	2.1560.006.0	12	gasket 10.2 x 16
25	0.065.1160.3/20	6	valve
26	2.1470.004.2	34	lock washer 8
27	2.0112.237.2	2	screw m 8 p.1.25x140
28	2.0112.215.2	25	screw m 8 p.1.25 x 40
29	0.007.0991.0	1	oil sump
30	2.0112.229.2	3	screw m 8 p.1.25 x 100
30	2.0112.235.2	3	screw m 8 p.1.25 x 130
30	2.0112.241.2	1	screw m 8 p.1.25 x 160
31	0.007.0775.3	1	radiator
32	0.007.0878.0	2	gasket
33	2.1539.048.0	2	special oil seal 20.35x1.78
34	2.1539.153.2	2	-
35	2.1480.014.1	4	washer 8
36	2.1539.040.0	1	special oil seal 21.82 x 3.53
37	0.065.1538.0	1	flange
38	2.1011.105.2	1	nut m 8 p.1.25

523 - 6

Section: ENGINE
LUBRICATION => 1217

Fig.	P/n	QTY	Name
Notes: [ANTARES 110]			
1	2.0312.206.2	2	screw m 8 p 1.25 x 20
2	2.1480.014.1	2	washer 8
3	0.041.1135.4	1	plug 1" gas
4	2.1569.072.0	1	gasket 32 x 39.5 x 2
5	0.065.1565.0/10	1	pipe union
6	2.1539.042.0	1	special oil seal 47.35x1.78
7	0.065.1567.0/10	1	filter
8	2.3339.307.0	2	pipe fitting m 22 p.1.5-3/4"
9	0.007.0849.0/10	1	gasket
10	0.007.1312.3	1	tube
11	2.1470.004.2	1	lock washer 8
12	2.1470.004.2	1	lock washer 8
13	2.0112.205.2	1	screw m 8 p.1.25 x 16
14	0.080.1513.2/10	1	dipstick
15	2.1539.065.0	2	special oil seal 8.73 x 1.78
16	2.3199.001.2	1	plug 1/2" gas
17	2.1560.054.0	1	gasket 21 x 26
18	2.0112.221.2	2	screw m 8 p.1.25 x 60
19	0.044.1567.0	2	oil filter element
20	2.1560.014.0	1	washer 18.2 x 24
21	2.3339.353.2/20	1	pipe fitting 12 p.1.5-18 p.1.5
22	0.086.1550.2	6	sprayer nozzle
23	2.1099.108.2	6	special nut m 10 p.1
24	2.1560.006.0	12	gasket 10.2 x 16
25	0.065.1160.3/20	6	valve
26	2.1470.004.2	34	lock washer 8
27	2.0112.237.2	2	screw m 8 p.1.25x140
27	2.0112.241.0	2	-
28	2.0112.215.2	25	screw m 8 p.1.25 x 40
29	0.007.0991.0	1	oil sump 1462 <-
29	0.007.1311.0/10	1	oil sump -> 1463
30	2.0112.229.2	3	screw m 8 p.1.25 x 100
30	2.0112.235.2	2	screw m 8 p.1.25 x 130
30	2.0112.241.2	2	screw m 8 p.1.25 x 160
31	0.007.0775.3	1	radiator
32	0.007.0878.0	2	gasket
33	2.1539.048.0	2	special oil seal 20.35x1.78
34	2.0399.153.2	2	screw m 8 p.1.25
35	2.1480.014.1	4	washer 8

Section: ENGINE
LUBRICATION => 1217

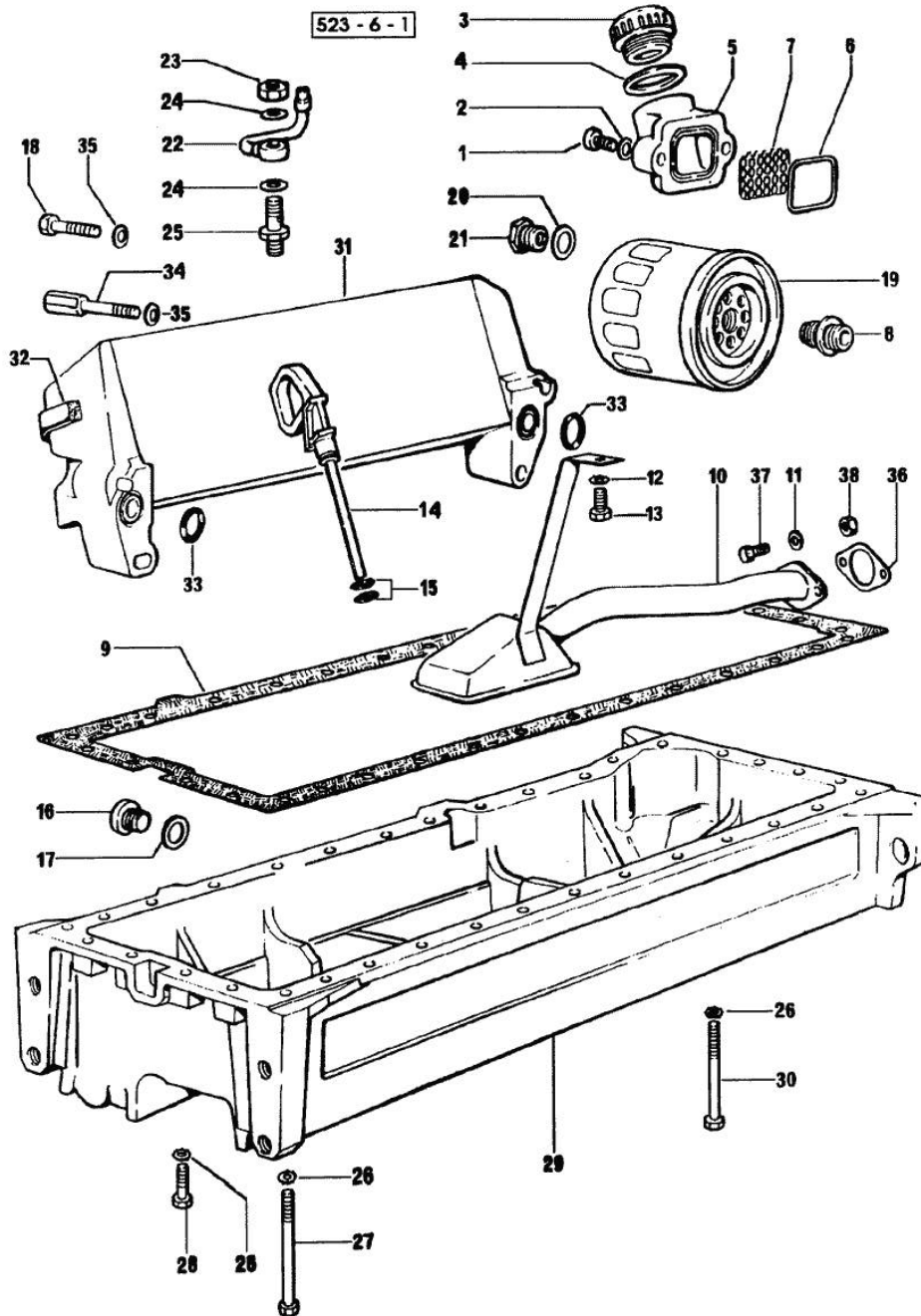
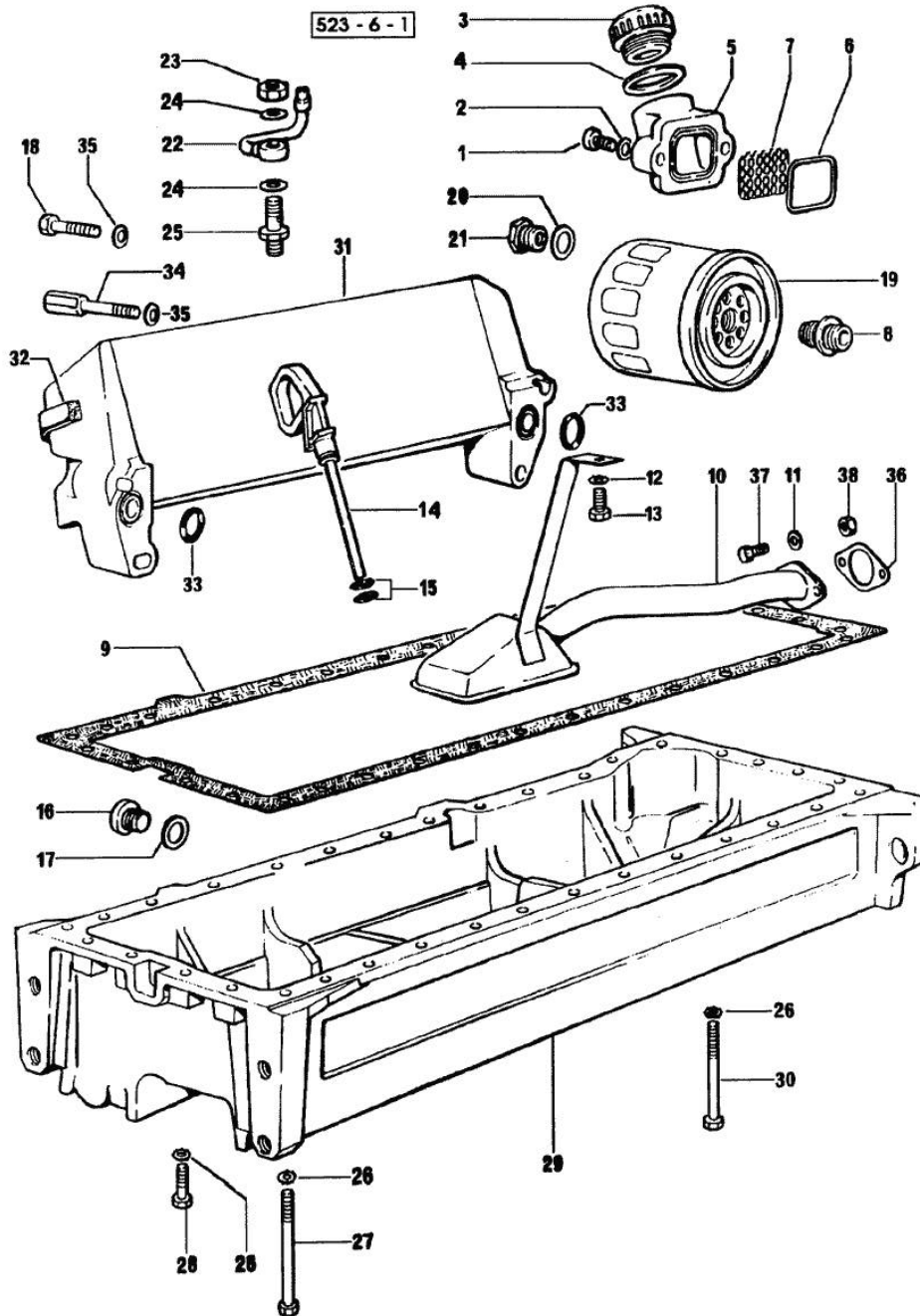

Fig.	P/n	QTY	Name
36	0.007.0997.0	1	gasket
37	2.0112.207.2	2	screw m 8 p 1.25 x 20
38	2.1011.105.2	1	nut m 8 p.1.25

Thank you so much for reading.
Please click the “Buy Now!”
button below to download the
complete manual.



After you pay.

You can download the most
perfect and complete manual in
the world immediately.

Our support email:

ebooklibonline@outlook.com