

Section: ENGINE
CRANKCASE

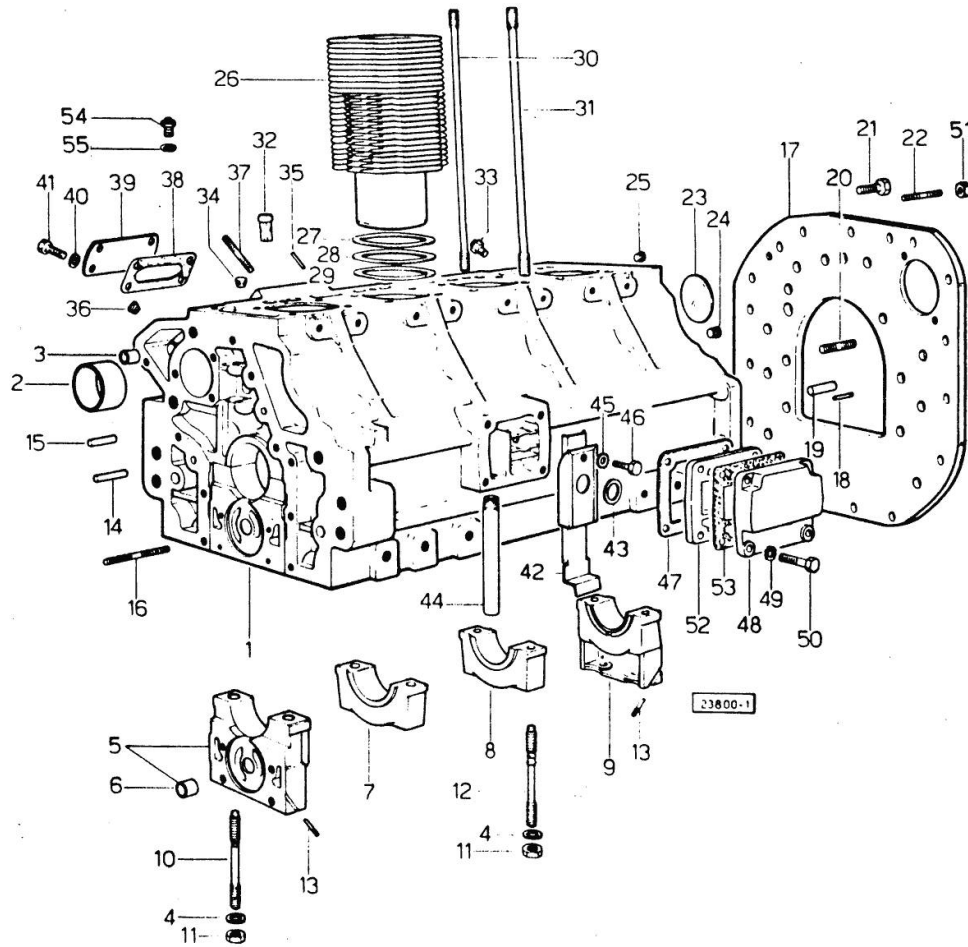

Fig.	P/n	QTY	Name
------	-----	-----	------

Notes:
[CORSARO 70 FRUTTETO]

0	0.063.0050.6	1	gasket set
1	0.045.1110.4	1	crankcase
2	0.037.1155.0	1	bushing
3	2.1559.111.0/20	2	special bushing
4	2.1599.144.7	10	shoulder ring 12.5x23x4
5	0.004.8774.3	1	support
6	2.1559.090.0/10	1	bushing 14.24x19.06x27
7	0.037.1114.0	1	support
8	0.052.1113.0	2	support
9	0.052.1116.0	1	support
10	0.021.1157.0	4	stud bolt
11	2.1019.026.7	10	special nut m 12 p.1.5
12	0.029.1117.0	6	stud bolt
13	0.029.1154.0/10	4	gasket
14	2.1699.114.0	1	pin 8x55
15	2.1651.711.0	1	pin 8 x 14
16	2.0432.025.7	2	stud bolt m 8 p.1.25 - 1.00 x 100
17	0.054.1130.0/10	1	flange
18	2.1653.708.0	2	pin 8x18
19	2.1651.911.0	2	cylindrical plug
20	2.0432.153.7	2	stud bolt m 10 p.1.5 / p.1.25 x 20
21	2.0112.511.2	13	screw m 14 p.2 x 30
22	2.0432.255.7	3	stud bolt m 12 p.1.75-1.25x25
23	2.3170.022.1	1	expansion plug 60
24	2.3130.003.1	2	plug 3/8" gas
25	2.3130.002.1	1	plug 1/4" gas
26	0.045.1120.0/10	4	engine cylinder
27	2.1589.052.0	8	shoulder ring 115x123x0.2
28	2.1589.051.0	4	shoulder ring 116x123x0.1
29	2.1569.076.0	4	gasket 116x123x0.5
30	0.041.1123.0/10	4	stud bolt
31	0.039.1122.0	16	stud bolt m 12 p.1.5x310
32	0.044.1156.0	8	special bushing
33	0.071.1151.3/10	4	valve
34	2.3130.001.1	3	plug 1/8" gas
35	2.1651.507.0	2	pin 6 x 16
36	2.3139.001.1	5	plug
37	2.0432.003.7	4	stud bolt m 8 p.1.25 / p.1 x 20
38	0.044.1151.0	1	gasket
39	0.044.1164.2/10	1	small cover
40	2.1310.004.2	4	flat washer 8.4x17

Section: ENGINE
CRANKCASE

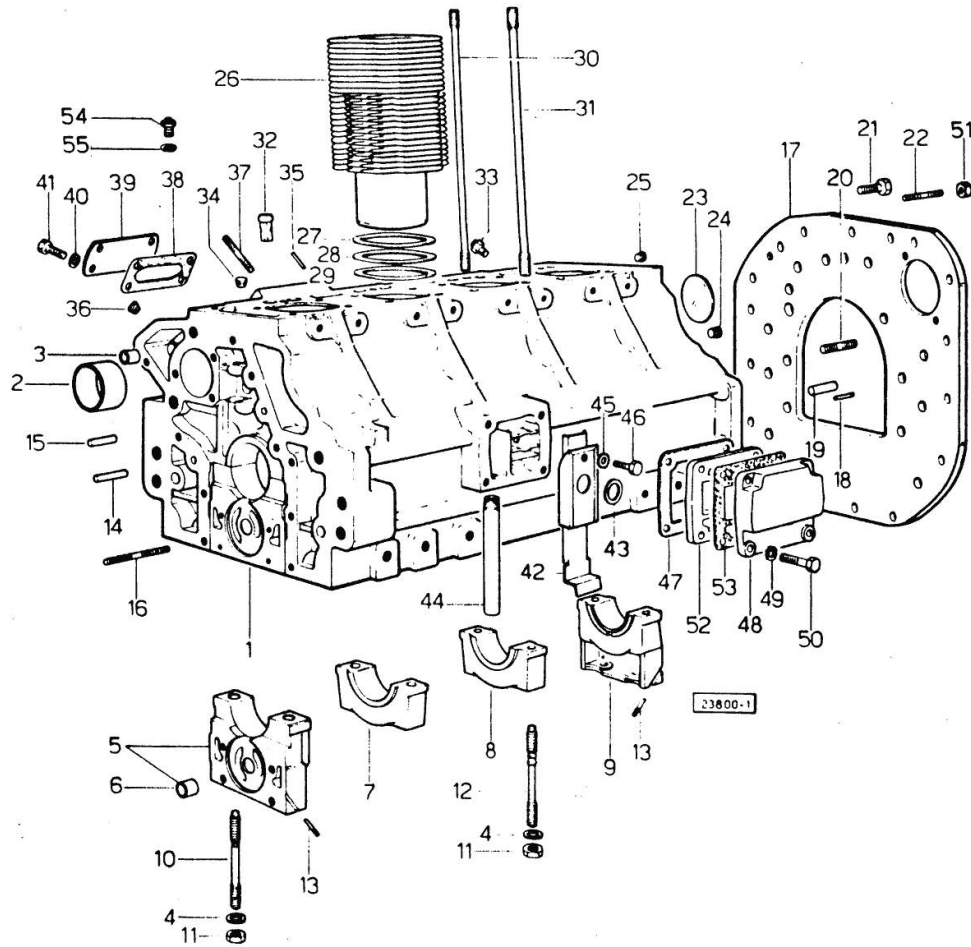

Fig.	P/n	QTY	Name
41	2.0112.204.2	4	screw m 8 p.1.25x14
42	0.044.1162.2	1	small guard
43	0.071.1156.0	1	special oil seal
44	0.044.1152.0/10	1	tube
45	2.1474.009.2	1	spring washer 8
46	2.0312.206.2	1	screw m 8 p 1.25 x 20
47	0.044.1153.0/10	1	gasket
48	0.044.1163.0	1	cover
49	2.1474.009.2	4	spring washer 8
50	2.0112.211.2	4	screw m 8 p.1.25 x 30
51	2.1011.207.2	2	nut m 12 p.1.5
52	0.044.1160.0/10	1	container
53	0.044.1161.0	1	gasket
54	0.054.1150.0	1	pipe fitting
55	2.1560.006.0	1	gasket 10.2 x 16

Section: ENGINE

TIMING CASE

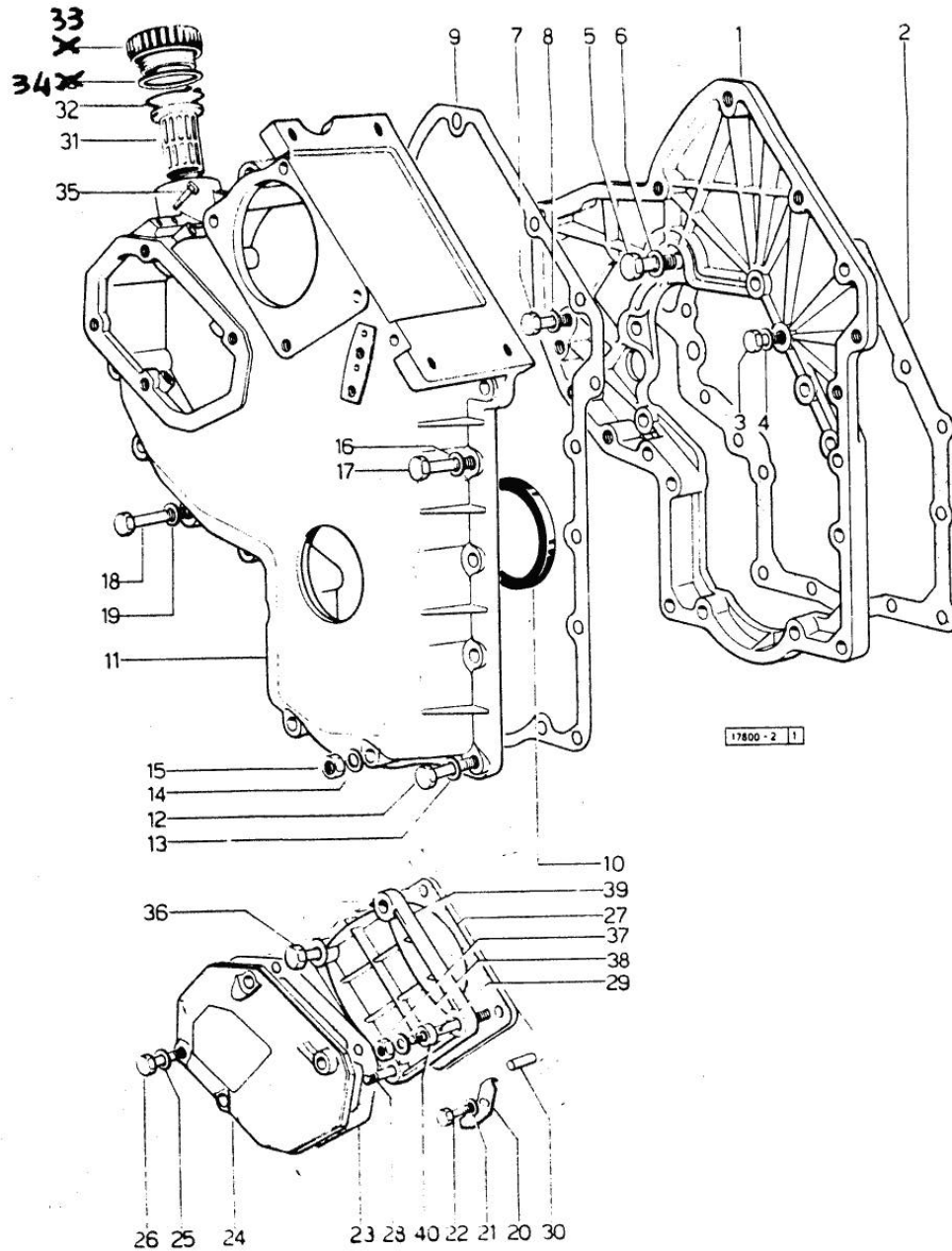

Fig.	P/n	QTY	Name
------	-----	-----	------

Notes:
[CORSARO 70 FRUTTETO]

1	0.048.1131.0	1	flange
2	0.041.1153.0/10	1	gasket
3	2.0112.209.2	5	screw m 8 p 1.25 x 25
4	2.1474.009.2	5	spring washer 8
5	2.0119.034.2	1	screw m 14 p.2x20
6	2.1560.010.0	1	gasket 14.2 x 20
7	2.0112.207.2	1	screw m 8 p 1.25 x 20
8	2.1474.009.2	1	spring washer 8
9	0.041.1152.0/10	1	gasket
10	2.1519.010.0	1	special oil seal 58x80x10
11	0.048.1132.0/40	1	guard
12	2.0112.217.2	5	screw m 8 p.1.25 x 45
13	2.1474.009.2	5	spring washer 8
14	2.1560.003.0	2	copper gasket 8.2 x 12
15	2.1011.405.2	1	nut m 8 p.1
16	2.1474.009.2	2	spring washer 8
17	2.0112.211.2	2	screw m 8 p.1.25 x 30
18	2.0112.222.2	4	screw m 8 p.1.25x65
19	2.1474.009.2	4	spring washer 8
20	0.041.1158.0	1	index
21	2.1310.004.2	1	flat washer 8.4x17
22	2.0112.204.2	1	screw m 8 p.1.25x14
23	0.048.1151.0/10	1	gasket
24	0.048.1150.0/20	1	cover
25	2.1560.005.0	4	copper gasket 10.2 x 14
26	2.0112.315.2	4	screw m 10 p.1.5 x 40
27	0.041.1154.0	1	gasket
28	2.0432.015.7	1	stud bolt m 8 p.1.25-1x50
29	2.0432.028.7	2	stud bolt m 8 p.1.25-1x130
30	2.1653.717.0	1	pin 8 x 40
31	0.041.1159.0/10	1	filter
32	2.1411.012.1	1	circlip 30
33	0.041.1135.4	1	plug 1" gas
34	2.1569.072.0	1	gasket 32 x 39.5 x 2
35	2.0112.004.2	2	screw m 6 p.1 x 14
36	2.0112.235.2	1	screw m 8 p.1.25 x 130
37	2.1011.405.2	4	nut m 8 p.1
38	2.1310.004.2	4	flat washer 8.4x17
39	0.037.1151.0/10	1	cover
40	2.1579.191.2	4	spacer 8.5 x 18 x 20

Section: ENGINE

CRANKSHAFT

Fig.	P/n	QTY	Name
------	-----	-----	------

Notes:
[CORSARO 70 FRUTTETO]

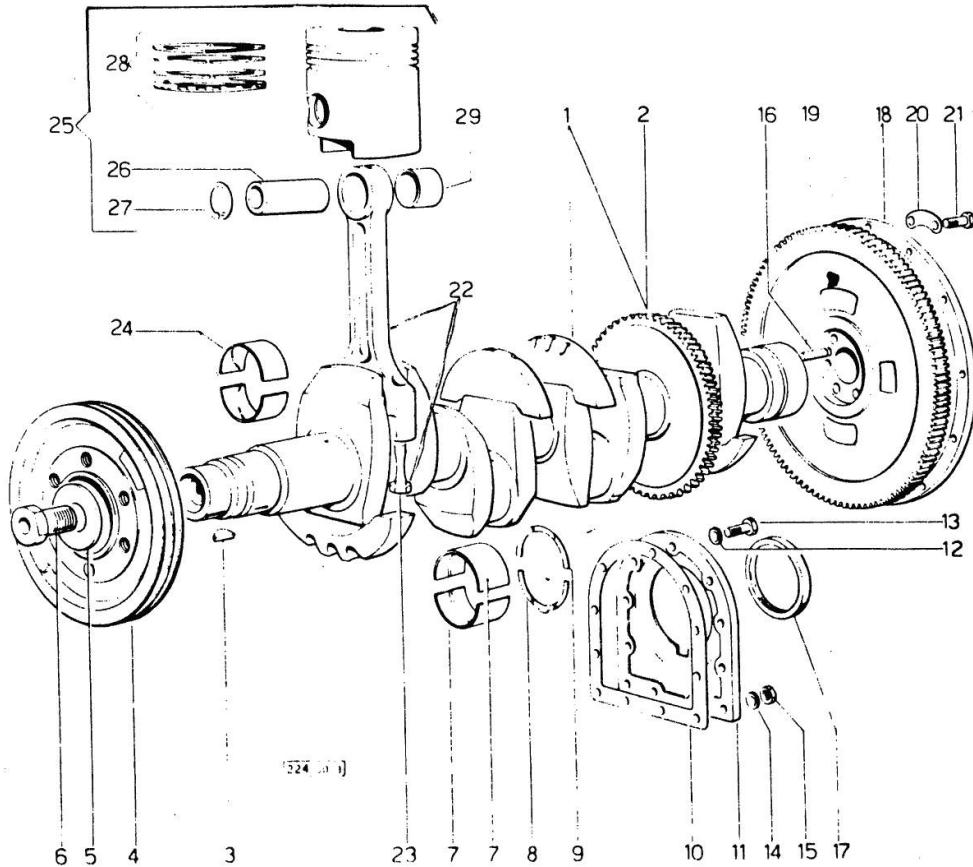

1	0.044.1267.4/30	1	crankshaft
1	2.1630.611.0	1	roll pin 6 x 24
2	0.044.1265.0/20	1	gear
3	2.1799.002.0	1	stick 10x13
4	0.062.1250.0	1	pulley
5	0.001.6020.0	1	shoulder
6	2.0129.032.2	1	screw m 24 p.2x45
7	0.073.0059.0	10	main half bushing - mm 1.00
7	0.073.1215.0	10	main half bushing STANDARD
7	0.073.1215.7	10	main half bushing - mm 0.25
7	0.073.1215.8	10	main half bushing - mm 0.50
7	0.073.1215.9	10	main half bushing - mm 0.75
8	0.001.4547.0	2	shoulder ring + mm 0.05
8	0.001.4548.0	2	shoulder ring + mm 0.10
8	0.001.4549.0	2	shoulder ring + mm 0.15
8	0.042.1219.0	2	shoulder ring STANDARD
9	0.001.4544.0	2	shoulder ring + mm 0.05
9	0.001.4545.0	2	shoulder ring + mm 0.10
9	0.001.4546.0	2	shoulder ring + mm 0.15
9	0.042.1218.0	2	shoulder ring STANDARD
10	0.029.1250.0/10	1	gasket
11	0.029.1240.0	1	flange
12	2.1474.010.2	7	washer 10
13	2.0112.309.2	7	screw m 10 p.1.5 x 25
14	2.1560.006.0	2	gasket 10.2 x 16
15	2.1011.421.2	2	nut m 10 p.1.25
16	2.1651.915.0	2	pin 12x35
17	2.1519.009.0/10	1	special oil seal
18	0.054.1241.3/20	1	flywheel
19	0.038.1242.0	1	crown wheel Z = 120, mm 15
20	2.1379.006.0	3	lock-tab 15x15x36,5
21	2.0122.515.7	6	screw
22	0.039.1220.3/30	4	engine connecting rod
23	0.039.1250.0	8	screw m 14 p.1.5x63
24	0.062.0059.0	8	con.rod half bushing - mm 1.00
24	0.062.1225.0	8	con.rod half bushing STANDARD
24	0.062.1225.7	8	con.rod half bushing - mm 0.25
24	0.062.1225.8	8	con.rod half bushing - mm 0.50
24	0.062.1225.9	8	con.rod half bushing - mm 0.75
25	0.053.0060.6/10	4	complete piston STANDARD
25	0.053.0061.6/10	4	complete piston + mm 0.50

Section: ENGINE
CRANKSHAFT

Fig.	P/n	QTY	Name
25	0.053.0062.6/10	4	complete piston + mm 1.0
26	0.002.4167.0	4	piston pin
27	2.1411.014.1	8	circlip 35
28	0.053.0052.6/10	4	piston ring set
28	0.053.0053.6/10	4	piston ring set + mm 0.50
28	0.053.0054.6/10	4	piston ring set + mm 1.0
29	2.1559.114.0/10	4	special bushing

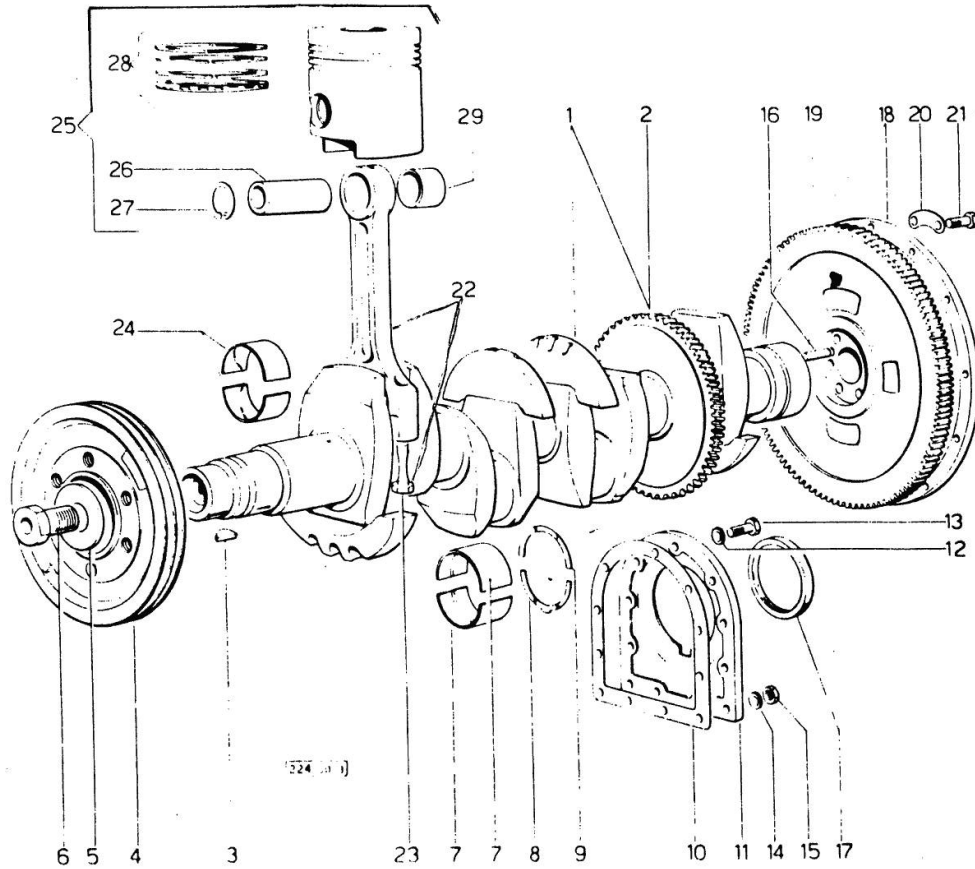

CRANKSHAFT - HARMONIC BALANCER

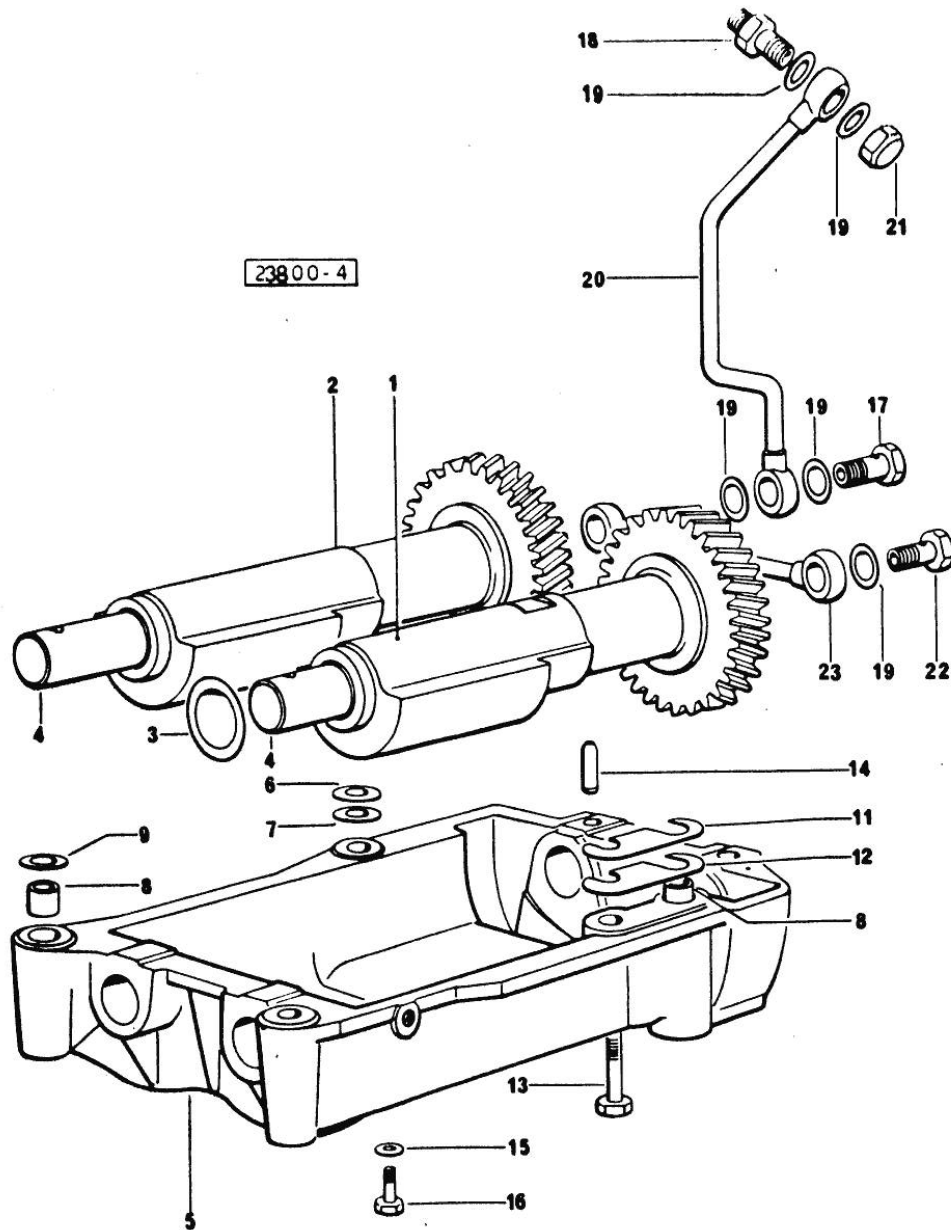

Fig.	P/n	QTY	Name
------	-----	-----	------

Notes:
[CORSARO 70 FRUTTETO]

1	0.044.1263.3/20	1	mass sx/lh/li
1	2.1559.115.0	2	special bushing 26x30x30
2	0.044.1261.3/10	1	mass dx/rh/re
2	2.1559.115.0	2	special bushing 26x30x30
3	2.1589.050.0/10	4	shoulder ring 26.1x38x1
4	0.044.1266.0/20	2	shaft
5	0.044.1260.0/30	1	support
6	2.1589.049.0	2	shoulder ring 12.5x26x0.3
7	2.1579.629.0	2	spacer 12.5x26x0.1
8	2.1579.626.0	2	spacer 13.2x16x11
9	2.1579.628.0	1	spacer 16.5x26x0.1
11	2.1379.038.0	1	shim mm 0.1
12	2.1379.039.0	1	shim mm 0.3
13	2.0112.426.2	4	screw m 12 p.1.75x85
14	2.1631.717.0	2	roll pin 8 x 40
15	2.1310.004.2	1	flat washer 8.4x17
15	2.1474.009.2	2	spring washer 8
16	2.0112.204.2	3	screw m 8 p.1.25x14
17	2.3339.515.1/10	1	pipe union m 12 p.1.25x39
18	2.3319.041.1	1	pipe union m 12 p.1.25-p.1.75
19	2.1560.008.0	7	gasket 12.2 x 18
20	0.044.1562.2	1	tube
21	2.1019.048.1	1	special nut m 12 p.1.5
22	2.3332.003.1	1	pipe union m 12 p.1.25
23	0.319.1550.3	1	tube

Section: ENGINE

CAMSHAFT

Fig.	P/n	QTY	Name
------	-----	-----	------

Notes:
[CORSARO 70 FRUTTETO]

1	0.044.1310.0/40	1	camshaft
2	2.3130.001.1	1	plug 1/8" gas
3	0.027.1314.0/20	1	flange
4	2.1470.004.2	2	lock washer 8
5	2.0112.207.2	2	screw m 8 p 1.25 x 20
6	0.062.1321.0	1	gear z=66
7	2.0139.005.1	4	screw m 10 p.1 x 25
8	0.040.1320.0	1	gear z = 33
9	2.1720.010.0	1	key 5x9
10	0.040.1323.0/10	1	gear Z = 38
11	0.052.1330.0/20	8	tappets
12	0.041.1331.3	8	rod
13	0.041.1332.0	8	sleeve
14	2.1539.020.0	8	special oil seal 13.95x2.62
15	2.1539.022.0	8	special oil seal 12.37x2.62
16	2.4019.162.1/20	8	spring 17.2x46x1.8
17	0.041.1355.3	1	transmission
18	2.1560.014.0	1	washer 18.2 x 24

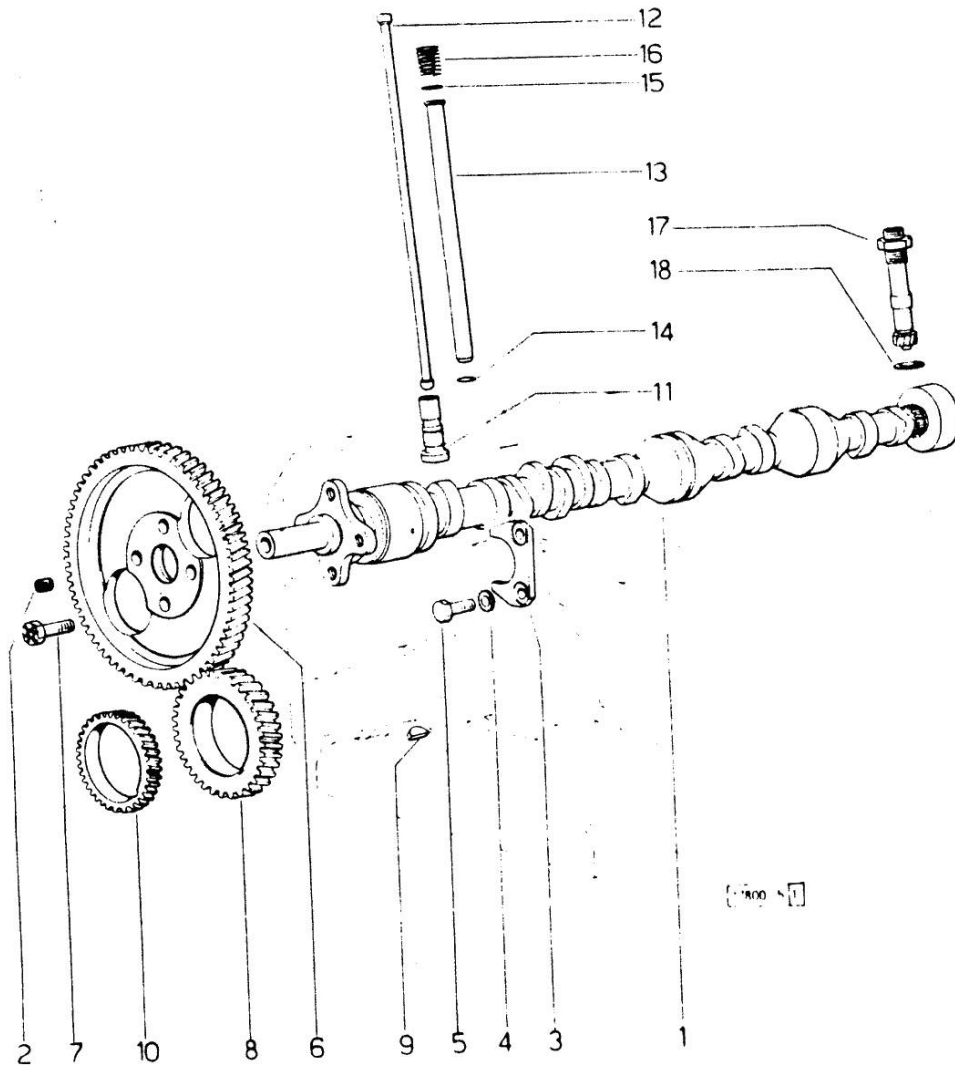

Section: ENGINE
CYLINDER HEAD

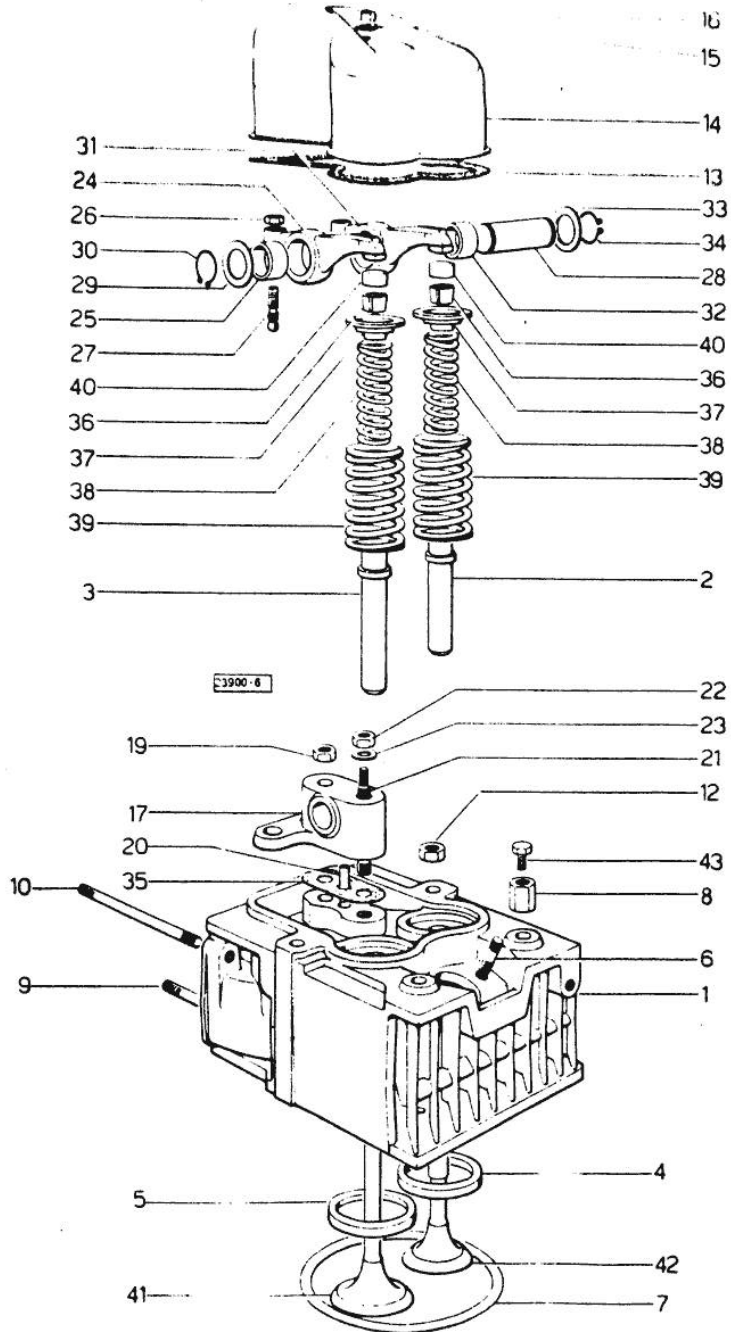

Fig.	P/n	QTY	Name
------	-----	-----	------

Notes:
[CORSARO 70 FRUTTETO]

0	0.072.0057.6	1	gasket set
1	0.045.1410.3	4	engine head
2	0.045.1417.0	4	valve guide
3	0.037.1416.0	4	valve guide
4	0.037.1452.0/10	4	valve seat
5	0.053.1450.0	4	valve seat
6	2.0439.087.1/20	8	stud bolt m 8 p.1.25 / p.1 x 40
7	2.1569.077.0/10	4	gasket
8	2.1019.037.0	6	special nut m 12 p.1.5
9	2.0432.007.2	7	stud bolt m 8 p.1.25 / p.1 x 30
10	2.0432.027.7	4	stud bolt m 8 p 1.25 - 1.00 x 120
12	2.1019.025.0	10	special nut m 12 p.1.5
13	0.029.1450.0/20	4	tappet gasket
14	0.039.1440.0	4	cap
15	2.1560.004.0	4	copper gasket 8.2 x 14
16	2.1099.056.2	4	special nut m 8 p.1 x 8
17	0.041.1430.0	4	support
19	2.1099.035.0	4	special nut m 10 p.1.25
20	0.029.1452.0	4	tube
21	0.039.1451.0	4	stud bolt
22	2.1011.421.2	4	nut m 10 p.1.25
23	2.1310.006.2	4	flat washer 10.5x21
24	0.002.5937.3/30	4	rocker arm
25	2.1559.021.0/40	4	bushing 15x19x22
26	2.1011.405.2	8	nut m 8 p.1
27	0.021.1434.0	8	screw
28	0.041.1431.0	4	pin
29	2.1599.019.0	4	shoulder ring 19.5x31x2
30	2.1410.055.7	4	circlip 19
31	0.002.5936.3/40	4	rocker arm
32	2.1559.021.0/40	4	bushing 15x19x22
33	2.1599.019.0	4	shoulder ring 19.5x31x2
34	2.1410.055.7	4	circlip 19
35	0.034.1450.0	4	tappet gasket
36	0.074.1423.0	8	conical valve cotter
37	0.002.9215.0/20	8	cup
38	2.4019.194.0	8	spring 22.70x50.7x2.1
39	2.4019.193.0	8	spring 36.15x55.2x3.2
40	0.021.1453.0/20	8	small cover
41	0.052.1420.0	4	inlet valve Ø mm 9
42	0.039.1421.0	4	exhaust valve Ø mm 9

Section: ENGINE
CYLINDER HEAD

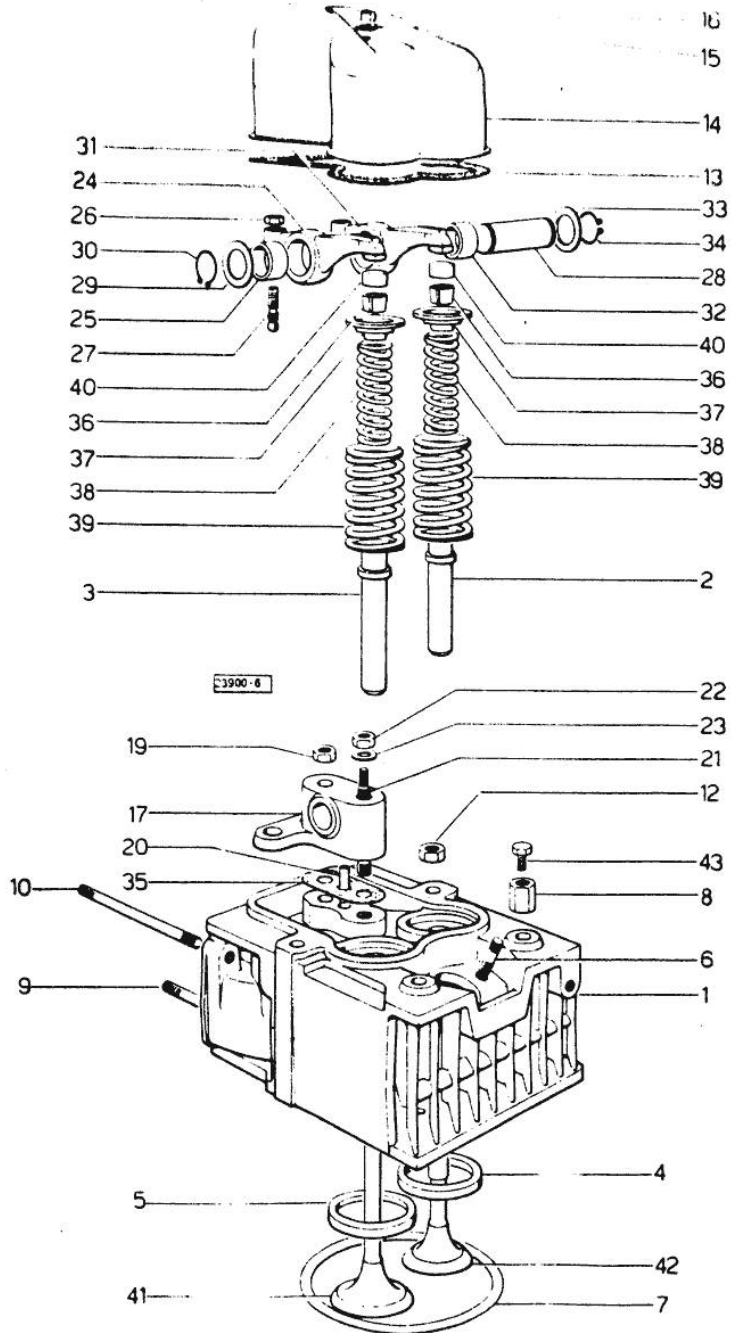

Fig.	P/n	QTY	Name
43	2.0119.053.1	2	screw

Section: ENGINE
LUBRICATION

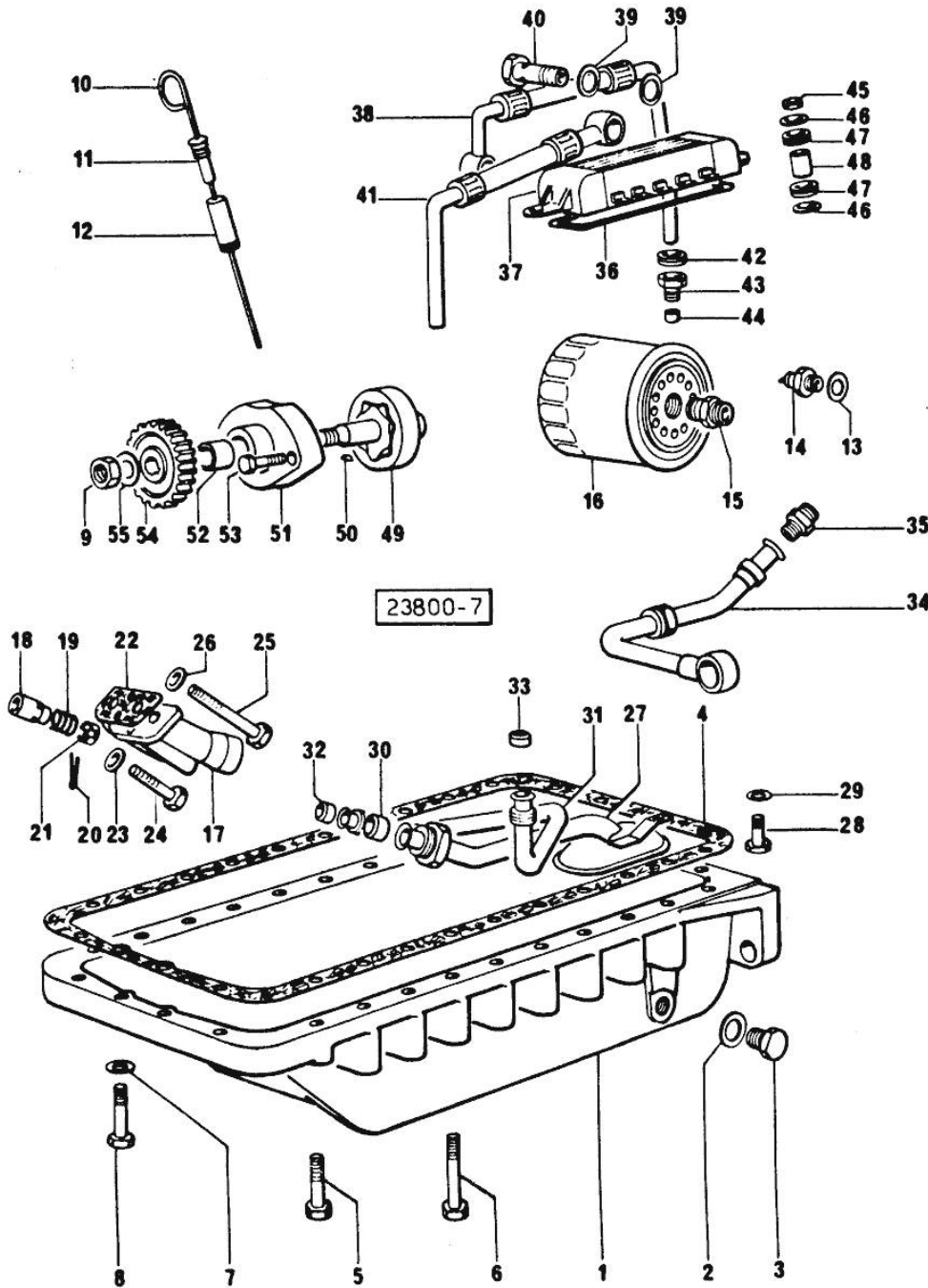

Fig.	P/n	QTY	Name
------	-----	-----	------

Notes:
[CORSARO 70 FRUTTETO]

1	0.045.1560.0/10	1	oil sump
2	2.1560.054.0	1	gasket 21 x 26
3	2.3199.001.2	1	plug 1/2" gas
4	0.036.1512.0	1	gasket
5	2.0112.211.2	4	screw m 8 p.1.25 x 30
6	2.0112.224.2	18	screw m 8 p.1.25x75
7	2.1560.004.0	4	copper gasket 8.2 x 14
8	2.0112.217.2	8	screw m 8 p.1.25 x 45
9	2.1121.109.2	1	self-locking nut m 12 p.1.25
10	0.036.1513.3	1	dipstick
11	0.034.1551.0	1	gasket
12	0.045.1566.0	1	spacer
13	2.1560.008.0	1	gasket 12.2 x 18
14	2.7099.460.0	1	pressure switch
15	2.3339.094.1/10	1	pipe fitting m 20 p.1.5-3/4 gas
16	0.044.1567.0	1	oil filter element
17	0.052.1530.0	1	tip
18	0.040.1550.0	1	small piston
18	0.052.1571.0	1	small piston => 3675
19	2.4019.241.1	1	spring
19	2.4019.270.1	1	spring 9.7x54x2 => 3675
20	2.1690.314.2	1	split pin 3.2x40
21	0.040.1551.0	1	stop
21	0.054.1558.0/20	1	stop => 3675
22	0.037.1557.0/20	1	gasket
23	2.1474.009.2	1	spring washer 8
24	2.0112.225.2	1	screw m 8 p.1.25 x 80
25	2.0112.231.2	1	screw m 8 p.1.25 x 110
26	2.1474.009.2	1	spring washer 8
27	0.045.1561.3	1	tube
28	2.0112.204.2	1	screw m 8 p.1.25x14
29	2.1310.004.2	1	flat washer 8.4x17
30	2.3359.014.1	1	nosepiece
31	0.044.1560.2	1	tube

Thank you so much for reading.
Please click the “Buy Now!”
button below to download the
complete manual.



After you pay.

You can download the most
perfect and complete manual in
the world immediately.

Our support email:

ebooklibonline@outlook.com