

Section: ENGINE
CRANKCASE

Fig.	P/n	QTY	Name
------	-----	-----	------

Notes:
 [EXPLORER 70 C]

0	0.065.0050.6	1	gasket set FOR ENGINE ASSEMBLY 916.4 A
0	0.086.0050.6	1	gasket set FOR 1000.4A ENGINE ASSEMBLY
1	2.0312.219.2	2	screw m 8 p.1.25x65
2	2.1470.004.2	2	lock washer 8
3	0.065.1143.3/10	1	body (...) <-
4	2.6859.072.2	1	clamp (...) <-
5	0.065.1156.0	2	gasket (...) <-
6	0.065.1155.0/10	1	tube (...) <-
7	0.065.1157.0	1	bracket (...) <-
8	2.1099.108.2	4	special nut m 10 p.1
9	2.1560.006.0	8	gasket 10.2 x 16
10	0.086.1550.2	4	sprayer nozzle
11	0.065.1160.3/20	4	valve
12	2.1539.047.2	1	old part number
13	2.3199.405.2	1	plug m 28 p.1.5
16	2.0439.154.1	12	old part number
19	2.1519.096.0/10	4	oil seal 107.67x1.78 X 1000.4A
19	2.1589.154.0	4	shoulder ring X 916.4 A
19	2.1589.155.0	4	shoulder ring X 916.4 A
19	2.1589.156.0	4	shoulder ring X 916.4 A
20	0.065.1120.0/10	4	engine cylinder X 916.4 A
20	0.085.1120.0/10	4	engine cylinder X 1000.4 A
21	2.0112.207.2	2	screw m 8 p 1.25 x 20
22	2.1470.004.2	2	lock washer 8
23	0.065.1163.0	1	flange
25	0.066.1152.0/10	4	gasket
26	0.065.1110.4/20	1	crankcase X 916.4 A

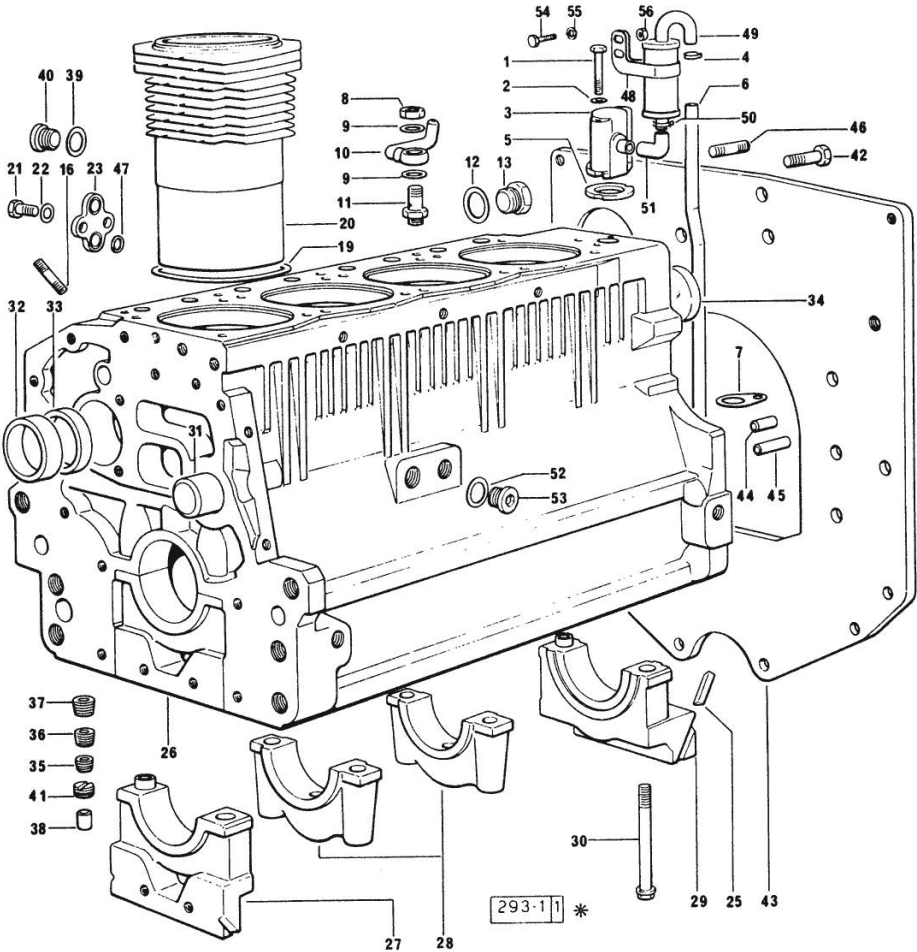

Section: ENGINE
CRANKCASE

Fig.	P/n	QTY	Name
26	0.086.1110.4/30	1	crankcase X 916.4 A
27	0.065.1112.7	1	support
27	2.1699.165.0	1	bush 12.3x15x16
28	0.065.1114.7/10	3	support
29	0.065.1116.7	1	support
29	2.1699.165.0	1	bush 12.3x15x16
30	0.065.1117.0	10	screw m 12 x 100
31	0.066.1151.0	1	pin
32	0.065.1141.0	1	special bushing 59X55X30
33	0.065.1140.0	4	special bushing 59X55X20
34	2.3179.012.0	1	plug 60
35	2.3130.001.1	10	plug 1/8" gas
36	2.3130.002.1	2	plug 1/4" gas
37	2.3130.003.1	7	plug 3/8" gas
38	2.3199.092.0	4	plug 8 x 12
39	2.1560.017.0	1	gasket 22.2 x 27
40	2.3120.002.4	1	plug m 22 x 1.5
41	2.1324.011.0	1	plug
42	2.0112.511.1	8	screw m 14 p.2 x 30
43	0.065.1164.0	1	flange 3247 <-
43	0.065.1164.0/10	1	flange >- 3247
44	2.1651.912.0	2	cylindrical plug 12x28
45	2.1651.917.0	1	cylindrical plug 12x40
46	2.0432.255.1	2	stud bolt m 12 p.1.75 - 12 p1.25x25
47	2.1539.048.0	2	special oil seal 20.35x1.78
48	2.6859.074.2/10	1	clamp (...) <-
49	0.065.1165.2	1	sediment bowl (...) <-
50	2.6859.073.2	2	clamp (...) <-
51	0.065.1166.0	1	sleeve (...) <-
52	2.1560.017.0	1	gasket 22.2 x 27
53	2.3120.002.4	1	plug m 22 x 1.5
54	2.0112.004.2	1	screw m 6 p.1 x 14
55	2.1470.002.2	1	lock washer 6
56	2.1011.103.2	1	nut m 6 p.1

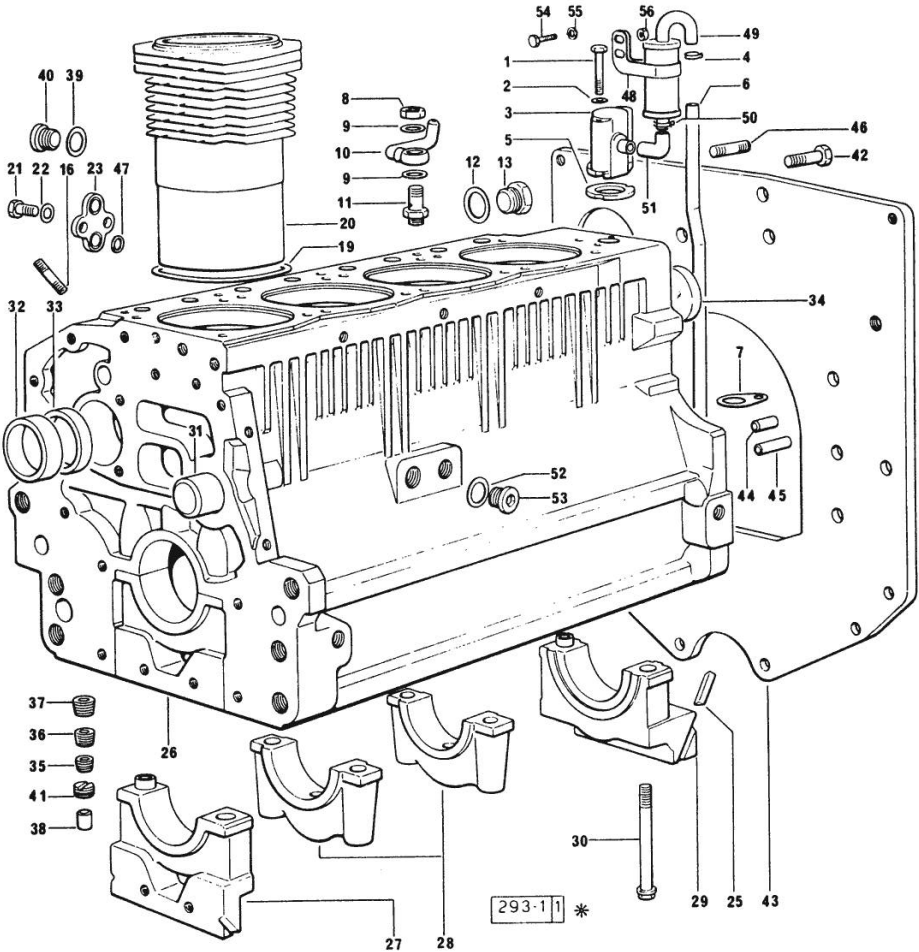

Section: ENGINE
TIMING CASE

Fig.	P/n	QTY	Name
------	-----	-----	------

Notes:
[EXPLORER 70 C]

1	0.065.1132.0/20	1	guard
2	0.065.1150.0/10	1	gasket
3	0.065.1152.0	1	gasket
4	0.065.1151.0	1	cover
5	2.1470.004.2	4	lock washer 8
6	2.0112.205.2	2	screw m 8 p.1.25 x 16
7	2.0432.001.1	2	stud bolt m 14 p.2-1.5x35
8	2.1011.405.2	2	nut m 8 p.1
9	2.0312.208.1	8	screw m 8 p.1.25 x 25
10	2.1480.014.1	15	washer 8
11	2.0432.003.7	2	stud bolt m 8 p.1.25 / p.1 x 20
13	2.0312.214.1	3	screw m 8 p.1.25 x 40
13	2.0312.219.2	4	screw m 8 p.1.25x65
14	2.1529.072.0	1	oil seal

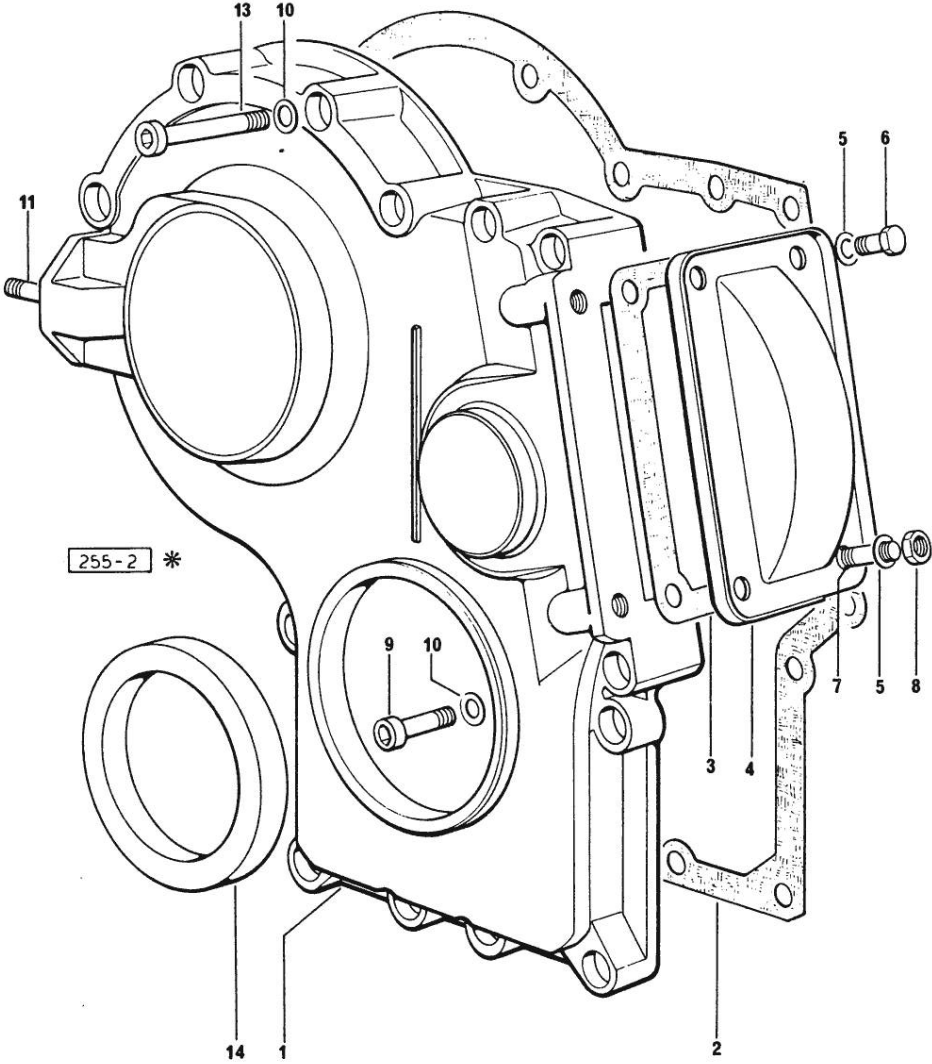

Section: ENGINE

CRANKSHAFT

Fig.	P/n	QTY	Name
------	-----	-----	------

Notes:
[EXPLORER 70 C]

1	0.065.1210.3/20	1	old part number 4136 <- - X 916.4A
1	0.066.1210.3/20	1	crankshaft -> 4137 - PER MOTORE 916.4A
1	0.086.1210.3/10	1	crankshaft X 1000.4 A
2	0.065.1211.0/10	1	crown wheel
3	2.1630.608.0	1	pin 6x16
4	2.3130.001.1	4	plug 1/8" gas
5	0.065.1220.3/10	4	engine connecting rod X 916.4 A
5	0.078.1220.3/10	4	engine connecting rod - X 1000.4 W X 1000.4 A
6	2.0139.021.0	8	screw X 916.4 A
7	0.065.1227.0	4	special bushing X 916.4 A
7	2.1559.114.0/10	4	special bushing X 1000.4 A
8	2.1411.013.1	8	circlip 32 X 916.4 A
8	2.1411.014.1	8	circlip 35 X 1000.4 A
9	0.065.1236.0	4	piston pin X 916.4 A
9	0.078.1236.0	4	piston pin Ø 18 / Ø 35 / L = mm 86 X 1000.4 A
10	2.1720.006.0	2	key 4x6.5
11	0.065.1248.0/10	1	hub 14531 <-
11	0.085.1248.0	1	hub -> 14532
12	2.1589.136.0	1	shoulder ring 71x110x0.5 14531 <-
12	2.1589.137.0	1	shoulder ring 71x110x1 14531 <-
12	2.1589.189.0	1	shoulder ring mm 1.00 -> 14532
13	2.0399.095.2/10	1	screw
14	2.1599.503.2	1	shoulder ring
15	2.0112.317.2	6	screw m 10 p.1.5 x 45

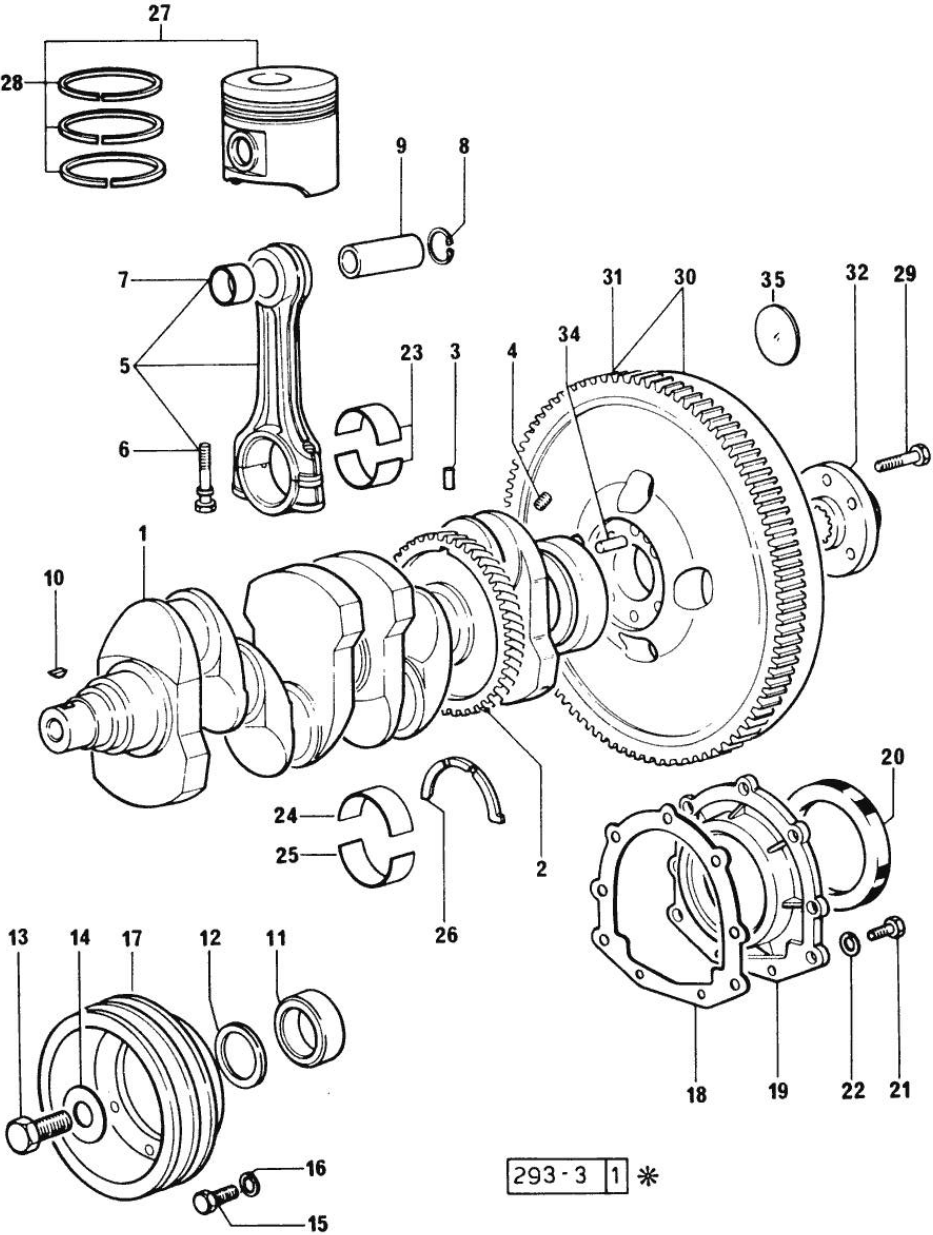

Section: ENGINE
CRANKSHAFT

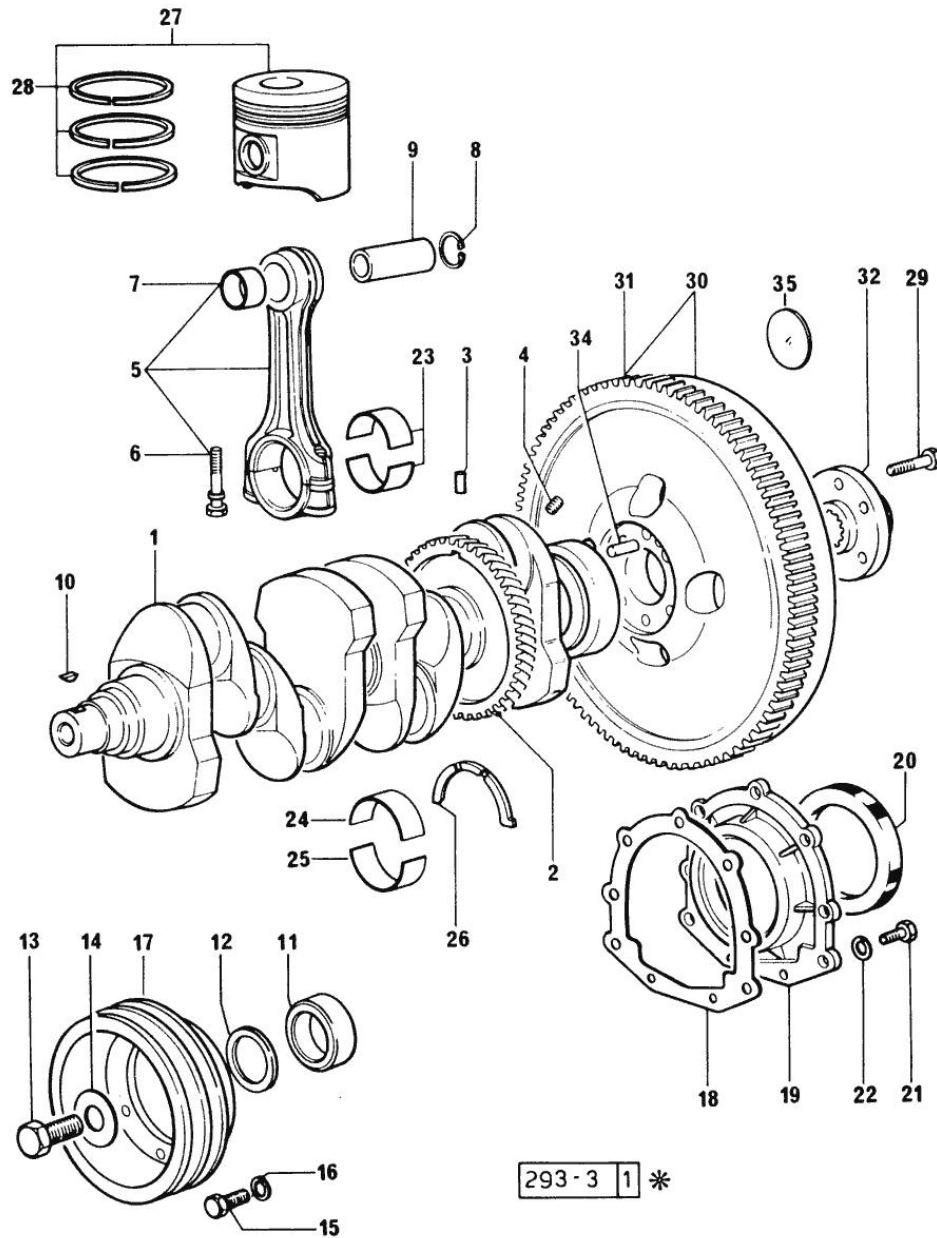
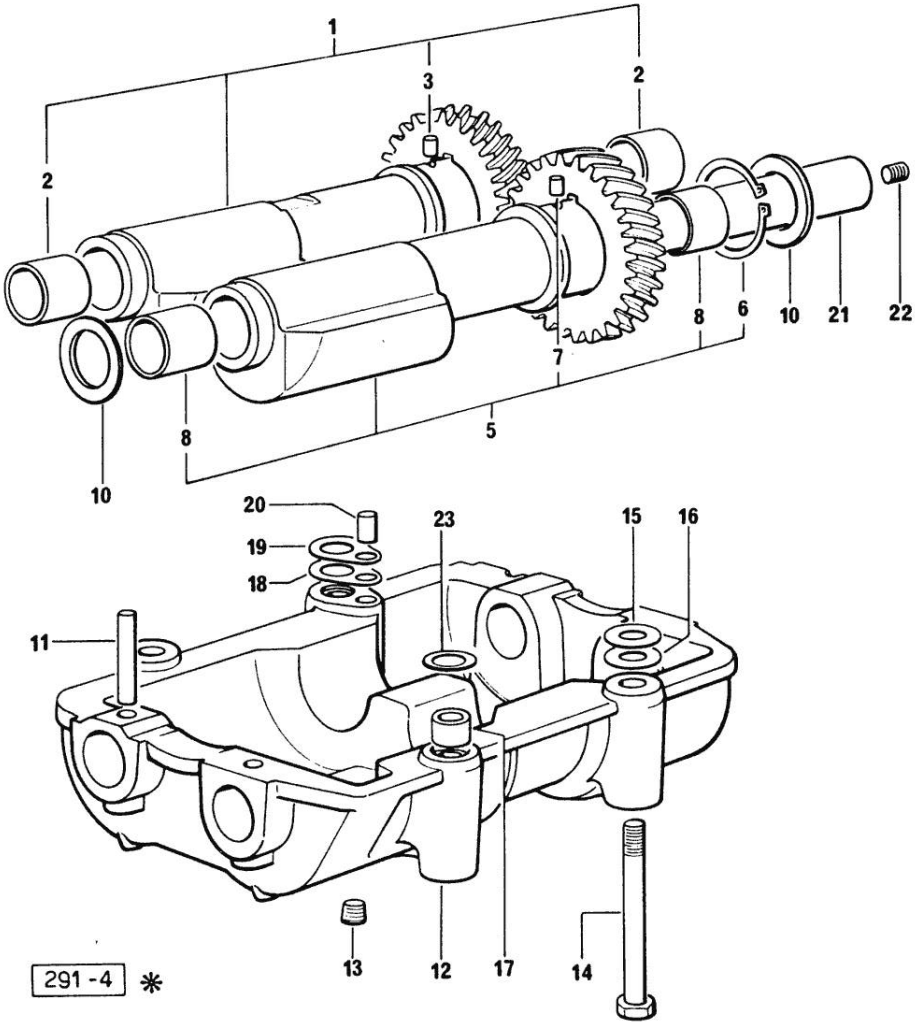

Fig.	P/n	QTY	Name
16	2.1470.006.2	6	lock washer 10
17	0.065.1244.0	1	pulley 14531 <-
17	0.085.1244.0	1	pulley -> 14532
18	0.065.1254.0	1	gasket
19	0.065.1253.0	1	old part number
20	2.1529.073.0	1	special oil seal 110x130x13
21	2.0112.207.2	9	screw m 8 p 1.25 x 20
22	2.1474.009.2	9	spring washer 8
23	0.065.1225.0	8	con.rod half bushing STANDARD - A = 28.75 -> 29.00
24	0.065.1215.0	5	main half bushing STANDARD
25	0.065.1216.0	5	main half bushing
26	0.065.1218.0	4	shim STANDARD
27	0.069.0060.6	4	complete piston STANDARD X 916.4A
27	0.086.0060.6	4	complete piston X 1000.4A
28	0.069.0052.6	4	piston ring set X 916.4 A
28	0.086.0052.6	4	piston ring set X 1000.4 A
29	2.0139.022.2	6	screw m 12 p.1.25x55
30	0.066.1247.3/20	1	flywheel 6180 <= ORDER ALSO. 1x 255.2320.3/10 - 6x 2.0112.207.2 - 6x 2.1474.009.1 - 3x 2.1699.173.0
31	0.065.1242.0	1	crown wheel Z = 123
32	0.255.2525.0/10	1	flange
34	2.1652.915.0	1	cylindrical plug 12x35
35	2.3199.135.2	1	plug

COUNTERWEIGHTS

Fig.	P/n	QTY	Name
------	-----	-----	------

Notes:
[EXPLORER 70 C]



1	0.086.1233.3/10	1	mass
2	2.1559.115.0	2	special bushing 26x30x30
3	2.1652.302.0	1	roll pin 4x6
5	0.065.1233.3/10	1	mass
6	2.1410.018.1	1	circlip 45
7	2.1652.302.0	1	roll pin 4x6
8	2.1559.115.0	2	special bushing 26x30x30
10	2.1589.185.0	4	shoulder ring 26.1x34x1
11	2.1631.717.0	2	roll pin 8 x 40
12	0.086.1231.3	1	old part number
13	2.3130.001.1	4	plug 1/8" gas
14	2.0112.427.2	3	screw m 12 p.1.75 x 90
15	2.1589.049.0	3	shoulder ring 12.5x26x0.3
16	2.1579.629.0	3	spacer 12.5x26x0.1
17	2.1579.626.0	2	spacer 13.2x16x11
18	2.1589.139.0	2	shoulder ring mm 0.3
19	2.1589.140.0	2	shoulder ring mm 0.1
20	2.1699.191.0	1	bush 7x10x16
21	0.065.1234.3	2	old part number
22	2.3130.001.1	2	plug 1/8" gas
23	2.1579.628.0	2	spacer 16.5x26x0.1
23	2.1589.048.0	2	shoulder ring 16.5x26x0.3

Section: ENGINE
CAMSHAFT

Fig.	P/n	QTY	Name
------	-----	-----	------

Notes:
 [EXPLORER 70 C]

1	0.065.1324.0	1	gear
1	0.066.1310.3/30	1	camshaft
2	0.065.1353.0	1	small plate
3	2.0312.205.2	2	screw
4	2.1480.014.1	2	washer 8
5	0.065.1323.0/20	1	gear Z = 29
6	0.065.1325.3/20	1	gear Z = 57
6	2.1559.185.0/10	1	bushing
7	065.1351.0	2	-
8	0.065.1352.0	1	shim
9	2.1410.016.1	1	circlip 40
10	0.065.1354.0/10	1	gear z=58
11	0.065.1350.0	1	small disc
12	2.0132.207.2	4	screw m 10 p.1 x 25
13	0.065.1330.0	8	tappets
14	2.1569.114.0	16	gasket
15	2.1599.437.0	8	shoulder ring
16	2.4019.300.1	8	spring
17	0.065.1332.0	8	sleeve
18	0.065.1331.2	8	rod

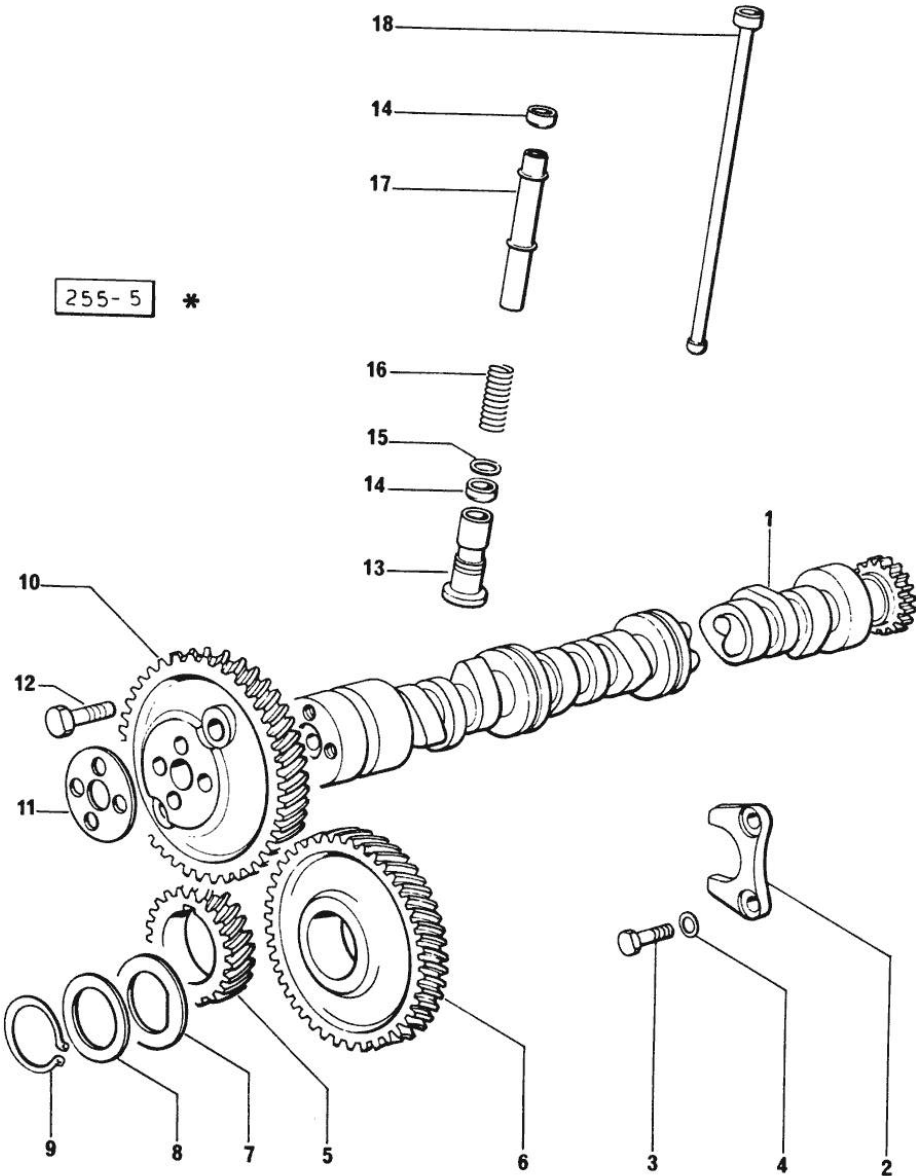

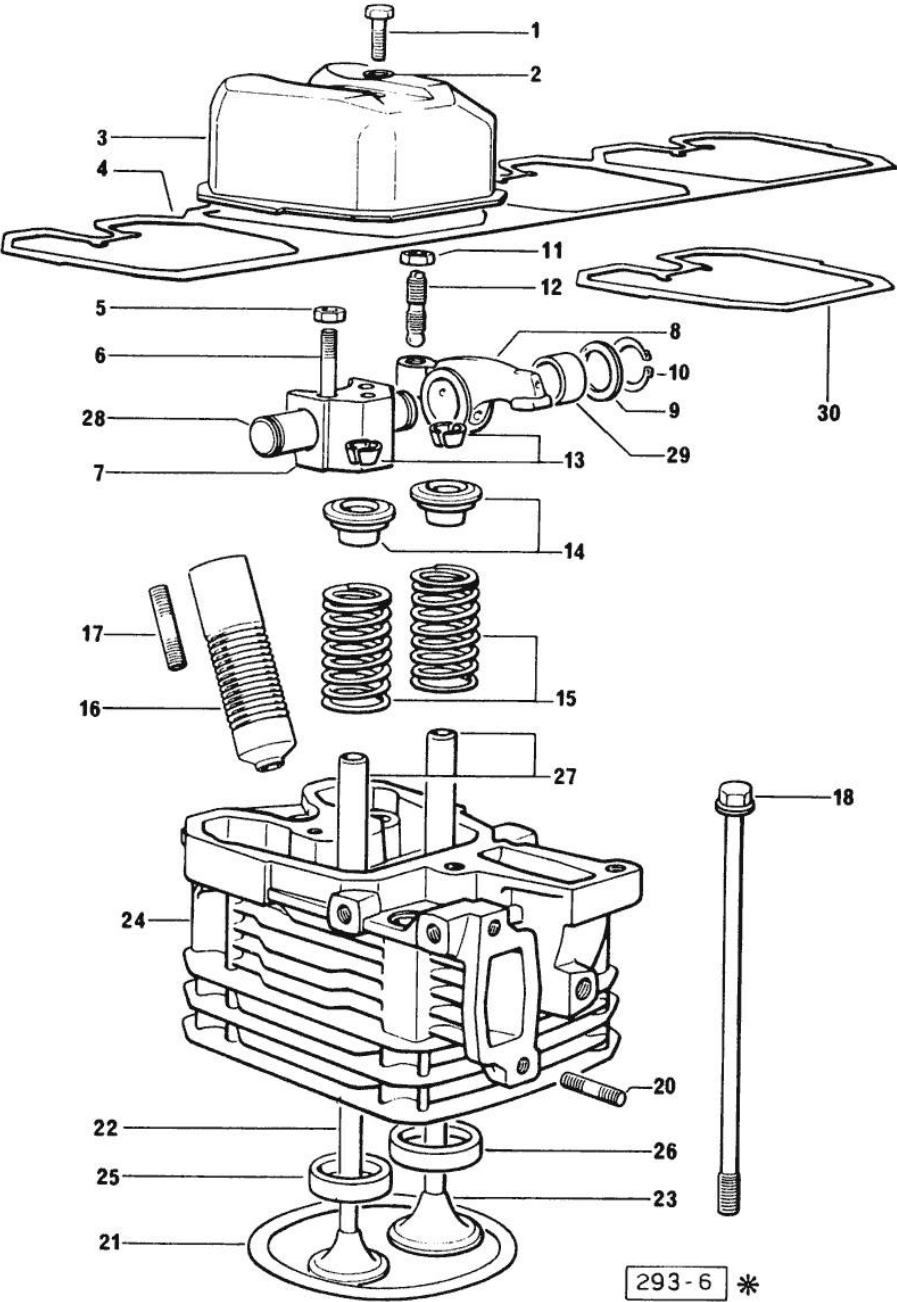

Section: ENGINE
CYLINDER HEAD

Fig.	P/n	QTY	Name
Notes: [EXPLORER 70 C]			
0	0.065.0057.6	4	gasket set - FOR 1 CYLINDER VALVE GRINDING AND PISTON RINGS REPLACEMEN - X 916.4 A
0	0.085.0057.6	4	gasket set - FOR 1 CYLINDER VALVE GRINDING AND PISTON RINGS REPLACEMEN - X 1000.4 A
1	2.0112.211.2	4	screw m 8 p.1.25 x 30
2	2.1560.204.0	4	gasket
3	0.066.1440.0/10	4	small cap
4	0.065.1450.0/10	1	gasket
5	2.1011.321.2	8	nut m 10 p.1.25
6	2.0432.163.1	8	stud bolt m 10 p.1.5 / p.1.25 x 45
7	0.066.1430.0	4	support
8	0.066.1432.0	8	rocker arm
9	2.1599.432.0	8	shoulder ring
10	2.1410.055.1	8	circlip 19
11	2.1011.405.2	8	nut m 8 p.1
12	0.021.1434.0	8	screw
13	0.074.1423.0	8	conical valve cotter
14	0.066.1425.0	8	cup
15	2.4019.287.0	8	spring
16	0.065.1413.0/10	4	bush L = mm 97.1
17	2.0432.161.7	4	stud bolt m 10 p.1.5 / p.1.25 x 40
18	0.065.1443.0/20	16	screw
20	2.0432.007.1	8	stud bolt m 8 p.1.25 / p.1 x 30
21	0.085.1450.0	4	head gasket mm 0.5 -A- X 1000.4 A
21	0.085.1451.0	4	head gasket mm 0.7 -B- X 1000.4 A
21	0.085.1452.0	4	head gasket mm 1.0 -C- X 1000.4 A
21	0.085.1453.0	4	head gasket mm 0.8 -D- X 1000.4 A
21	2.1569.112.0	4	gasket X 916.4 A
22	0.066.1421.0	4	exhaust valve
23	0.066.1420.0	4	inlet valve Ø mm 9 X 916.4 A
23	0.078.1420.0	4	inlet valve

Section: ENGINE
CYLINDER HEAD

Fig.	P/n	QTY	Name
24	0.065.1410.3/20	4	X 1000.4 A engine head
24	0.081.1410.3/10	4	X 916.4 A engine head
25	0.066.1427.0	4	X 1000.4 A valve seat
26	0.066.1426.0	4	X 916.4 A valve seat
26	0.078.1426.0	4	X 1000.4 A valve seat
27	0.066.1416.0	8	valve guide
28	0.066.1431.0	4	pin
29	2.1559.021.0/40	8	bushing 15x19x22
30	0.066.1450.0	4	tappet gasket

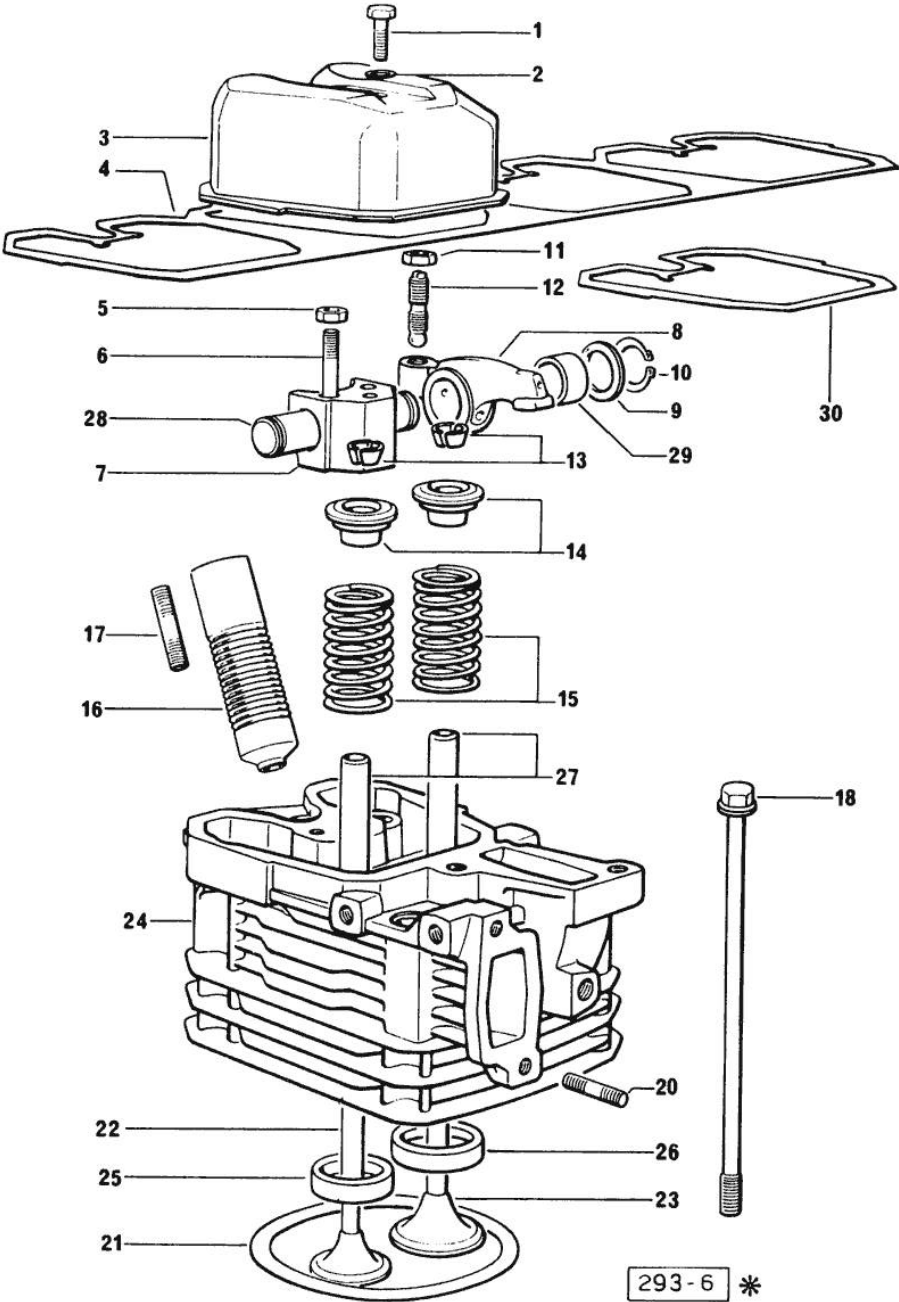

Section: ENGINE
LUBRICATION

Fig.	P/n	QTY	Name
------	-----	-----	------

Notes:
[EXPLORER 70 C]

1	0.065.1510.0/20	1	oil sump
2	0.065.1550.0	1	gasket
3	2.3199.001.2	1	plug 1/2" gas
4	2.1560.054.0	1	gasket 21 x 26
5	2.0112.227.2	6	screw m 8 p.1.25 x 90
5	2.0112.235.2	3	screw m 8 p.1.25 x 130
6	2.0112.215.2	17	screw m 8 p.1.25 x 40
7	2.1470.004.2	26	lock washer 8
8	0.065.1531.3	1	tube
9	2.0112.205.2	1	screw m 8 p.1.25 x 16
10	2.1011.105.2	1	nut m 8 p.1.25
11	2.1470.004.2	2	lock washer 8
12	0.065.1538.0	1	flange
13	2.1539.040.0	1	special oil seal 21.82 x 3.53
14	2.0312.216.1	2	screw
15	2.1310.004.2	4	flat washer 8.4x17
16	0.065.1540.3/20	1	oil cooler
17	2.1539.048.0	2	special oil seal 20.35x1.78
18	0.066.1513.2/10	1	dipstick mm 106
18	0.086.1513.2	1	dipstick
19	2.1539.065.0	2	special oil seal 8.73 x 1.78
20	0.066.1551.0	1	spacer
23	0.044.1567.0	1	oil filter element
24	2.3339.307.1/20	1	pipe fitting
25	2.3339.353.2	1	-
25	2.3339.353.2/10	1	(...) <- pipe fitting 12 p.1.5-18 p.1.5 -> (...)
26	2.1560.014.0	1	washer 18.2 x 24
27	2.0399.113.2/10	2	screw

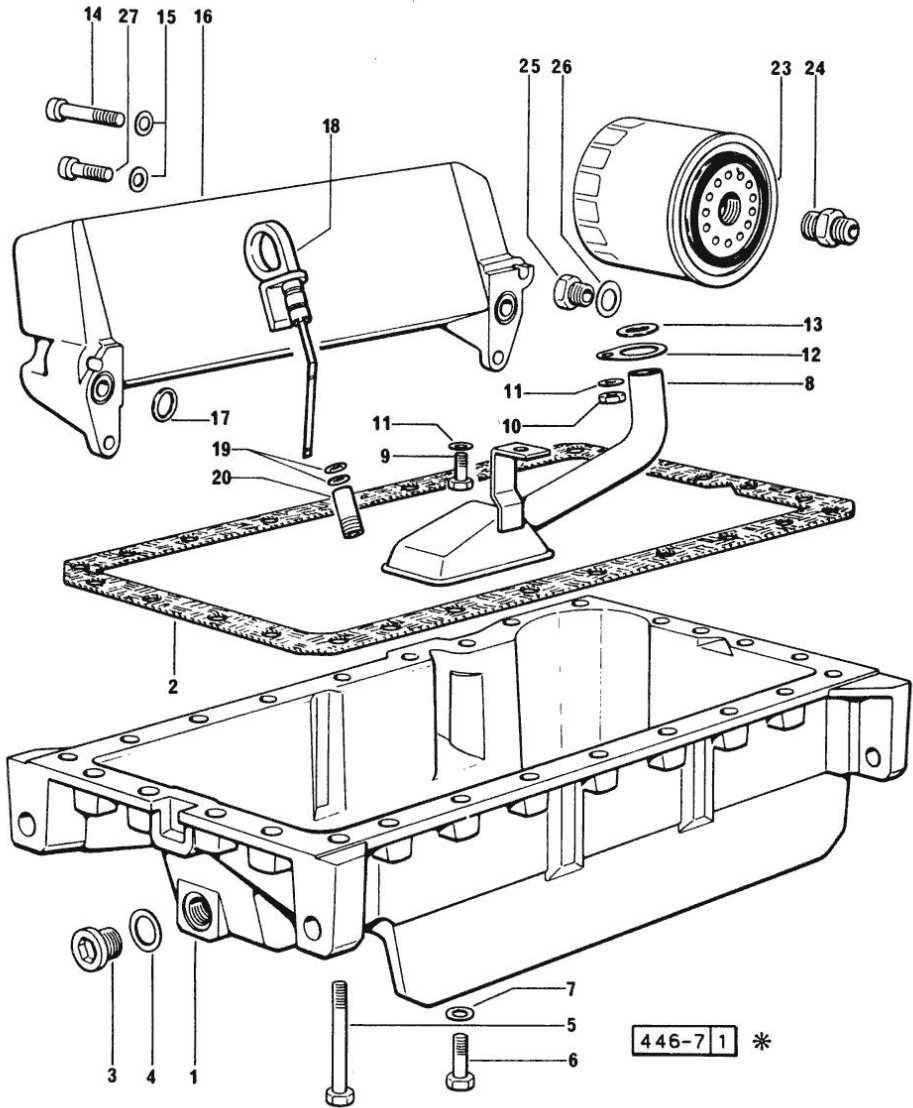

Thank you so much for reading.
Please click the “Buy Now!”
button below to download the
complete manual.



After you pay.

You can download the most
perfect and complete manual in
the world immediately.

Our support email:

ebooklibonline@outlook.com