

Section: ENGINE  
**CRANKCASE**

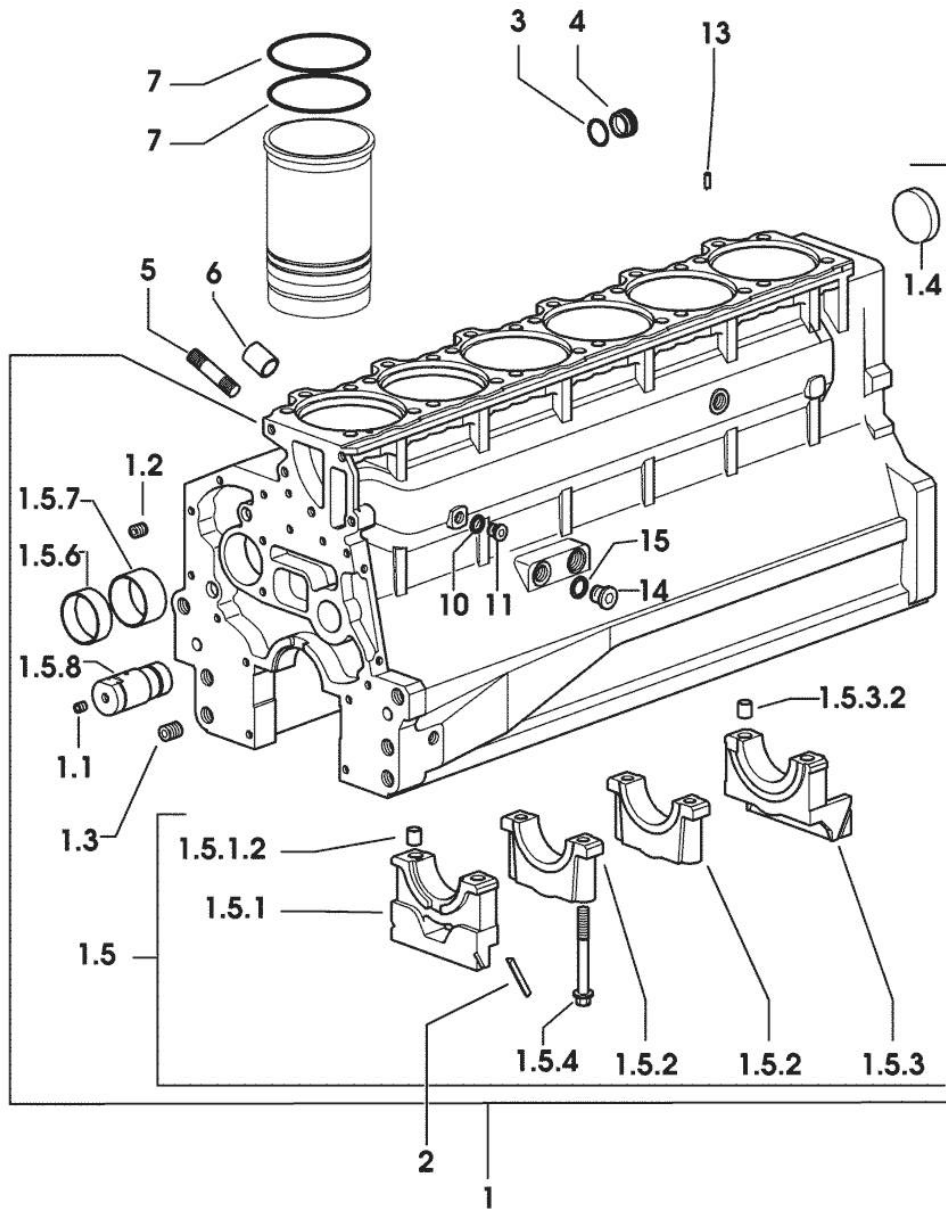

Fig.	P/n	QTY	Name
------	-----	-----	------

Notes:  
 [RUBIN 150]

1	0.007.1102.6/20	1	crankcase
1.1	2.3130.001.1	14	plug 1/8" gas
1.2	2.3130.002.1	2	plug 1/4" gas
1.3	2.3130.003.1	8	plug 3/8" gas
1.4	2.3179.012.0	1	plug 60
1.5	0.000.0000.1		cannot be supplied
1.5.1	0.065.1112.7	1	support
1.5.1.2	2.1699.165.0	1	bush 12.3x15x16
1.5.2	0.065.1114.0/10	5	support
1.5.3	0.007.0848.3/10	1	support
1.5.3.2	2.1699.165.0	1	bush 12.3x15x16
1.5.4	0.065.1117.0	14	screw m 12 x 100
1.5.6	0.065.1140.0	6	special bushing 59X55X20
1.5.7	0.065.1141.0	1	special bushing 59X55X30
1.5.8	0.066.1151.0	1	pin
2	0.066.1152.0/10	4	gasket
3	2.1532.072.0	1	oil seal 26.70x1.78
4	2.3199.405.2	1	plug m 28 p.1.5
5	2.0432.003.7	18	stud bolt m 8 p.1.25 / p.1 x 20
6	2.1559.188.2	6	bush 11.4 x 14 x16
7	2.1539.193.0	12	special oil seal 107.62x2.62
10	2.1560.010.0	1	gasket 14.2 x 20
11	2.3199.292.0	1	plug 1/4" gas
13	2.1549.154.2	6	bush 4.8x5.8x16
14	2.3120.101.0	1	plug m 18 p.1.5
15	2.1560.014.0	1	washer 18.2 x 24

9\_01311\_00\_0\_0

Section: ENGINE

**PISTON COOL.NOZZLE**

Fig.	P/n	QTY	Name
------	-----	-----	------

Notes:  
[RUBIN 150]

14	0.007.0638.2	6	sprayers
15	2.1099.108.2	6	special nut m 10 p.1
16	2.1560.006.0	12	gasket 10.2 x 16
17	2.3249.022.2	6	pipe fitting m 10 p.1

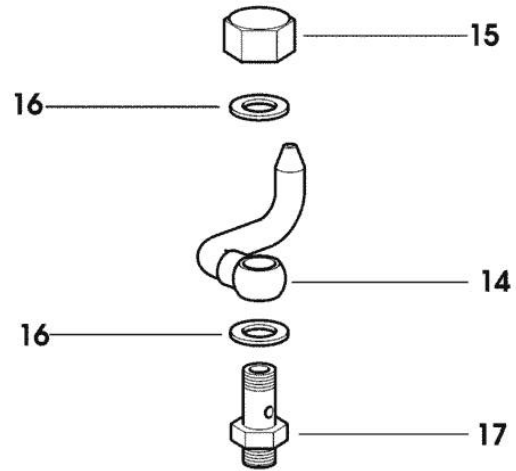

9\_34015\_02\_0\_0

Section: ENGINE  
**CONNECTING FLANGE**

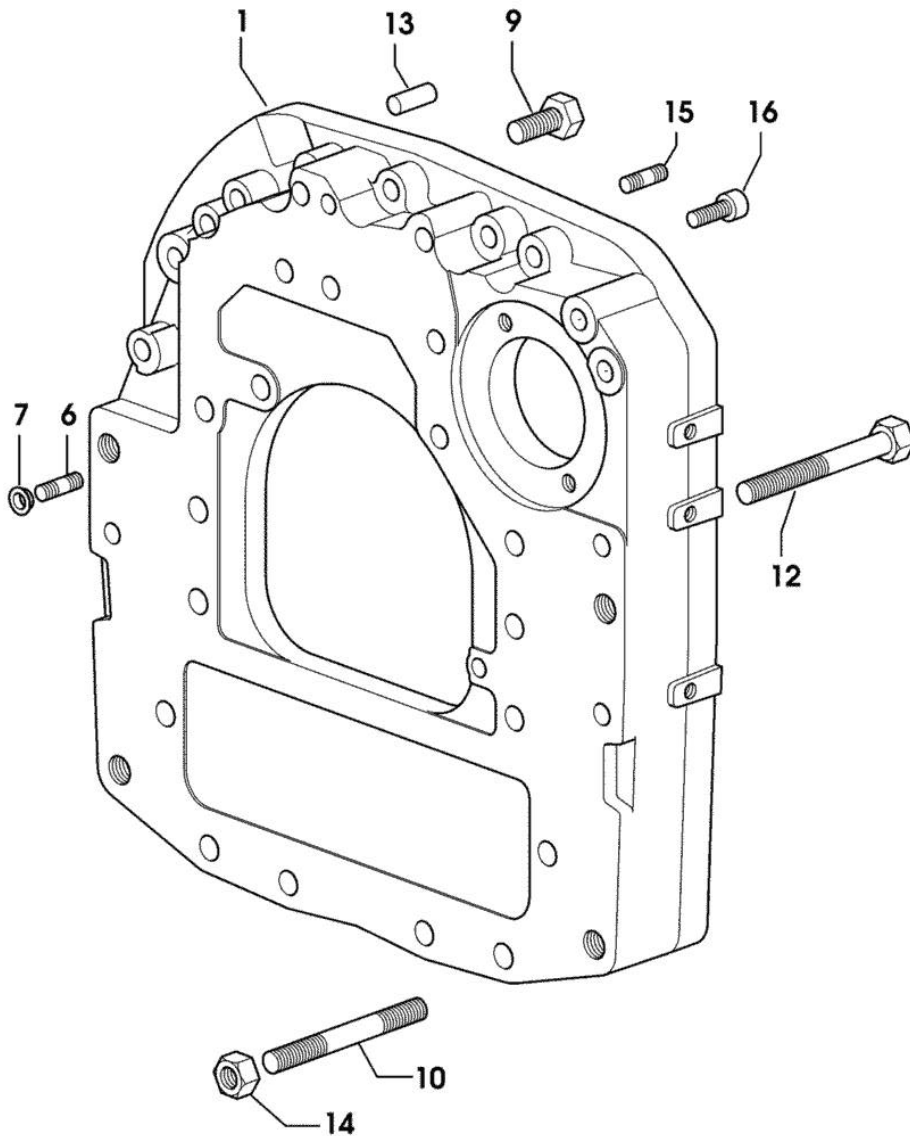

Fig.	P/n	QTY	Name
------	-----	-----	------

Notes:  
 [RUBIN 150]

1	0.011.2000.0/20	1	flange
6	2.0439.250.7	1	stud bolt m 12 / m 10 x 30
7	0.011.9294.0/10	1	bush
9	2.0112.513.2	11	screw m 14 p.2 x 35
10	2.0432.328.7	4	stud bolt m 14 p.2-1.5x130
12	2.0112.534.2	2	screw m 14 p.2x125
13	2.1651.911.0	2	cylindrical plug
14	2.1011.108.2	4	nut m 14 p.2
15	2.0432.257.7	1	stud bolt m 12 p.1.75 - 1.25 x 30
16	2.0312.520.2	2	screw m 14 p.2x70

9\_38411\_01\_0\_0

Fig.	P/n	QTY	Name
------	-----	-----	------

Notes:  
 [RUBIN 150]

1	0.007.1262.3/50	1	guard
2	0.007.1271.0/10	1	small column m 8 p.1.25 / L = mm 60
3	0.007.1272.0/10	2	small column m 8 p.1.25 / L = mm 50
5	2.1310.004.2	3	flat washer 8.4x17
7	2.0112.203.2	3	screw m 8 p.1.25 x 12

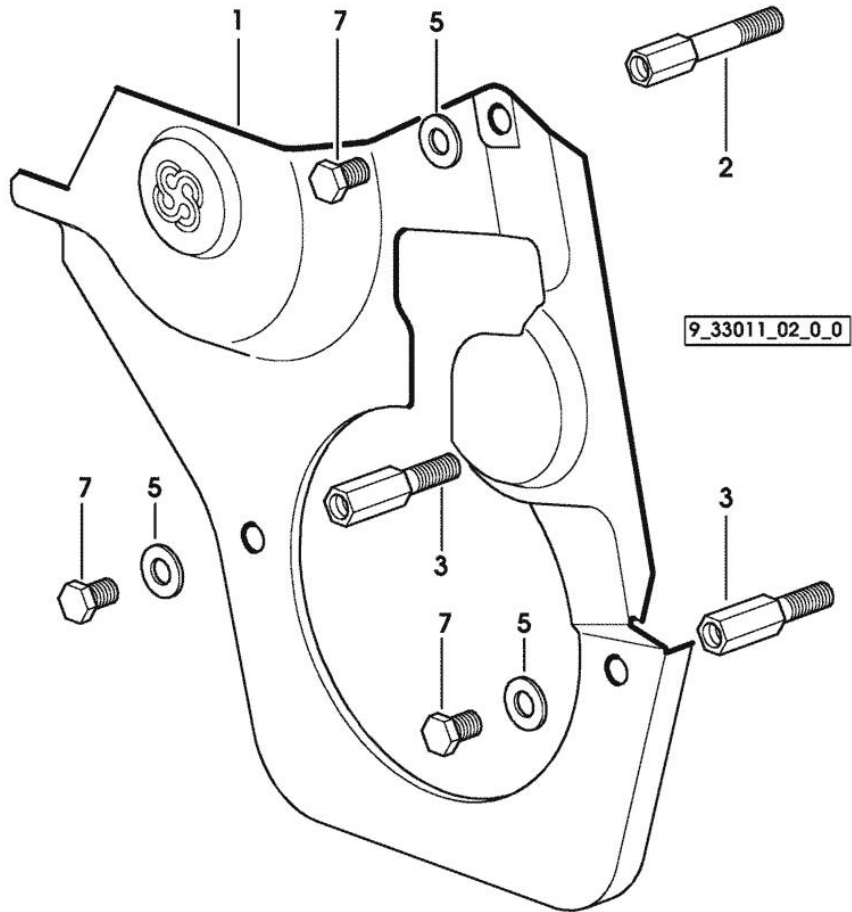

9\_33611\_01\_0\_0

RUBIN 150

Ref: 01.00.20

Section: ENGINE

**TIMING CASE**

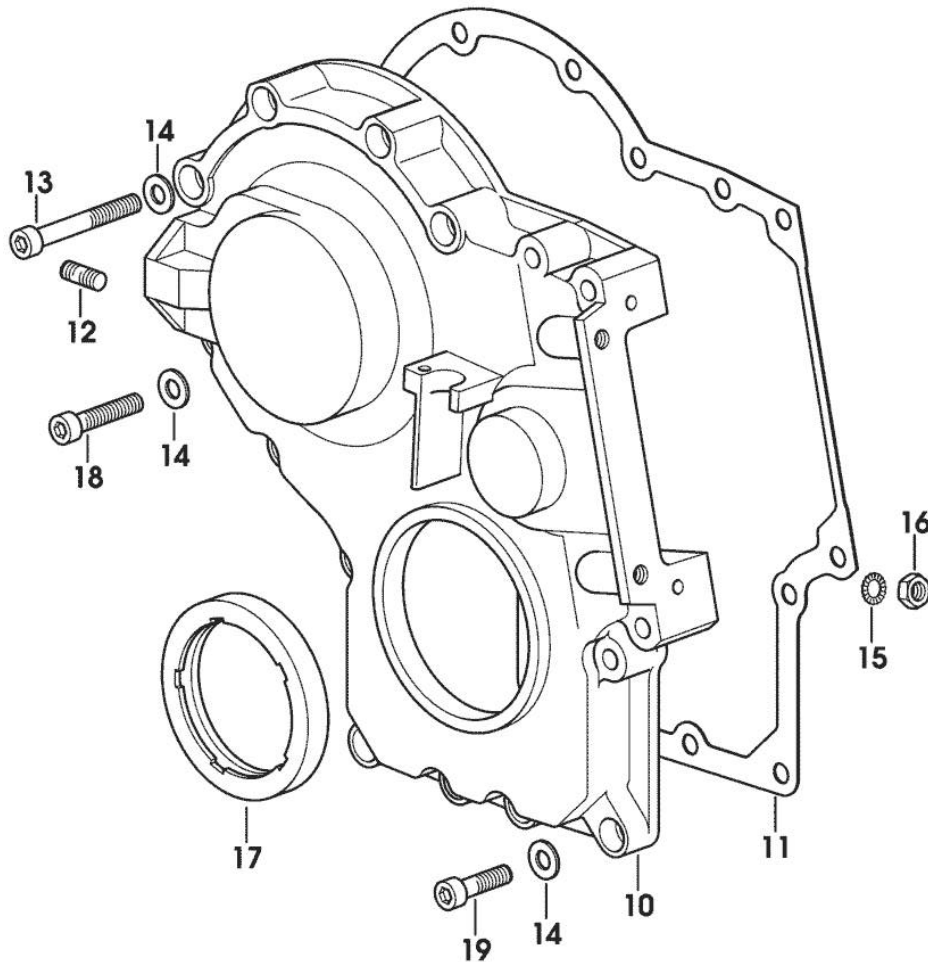

Fig.	P/n	QTY	Name
<b>Notes:</b>			
[RUBIN 150]			
10	0.013.4981.0	1	guard -> 1083 X RUBIN 120 -> 1197 X RUBIN 135 -> 1162 X RUBIN 150
10	0.065.1132.0/50	1	guard 1082 <- X RUBIN 120 1196 <- X RUBIN 135 1161 <- X RUBIN 150
11	0.065.1150.0/30	1	gasket
12	2.0432.003.7	2	stud bolt m 8 p.1.25 / p.1 x 20
13	2.0312.219.2	4	screw m 8 p.1.25x65
14	2.1480.014.1	15	washer 8
15	2.1470.004.2	4	lock washer 8
16	2.1011.405.2	2	nut m 8 p.1
17	2.1529.141.0	1	special oil seal
18	2.0312.214.2	3	screw m 8 p.1.25 x 40
19	2.0312.208.2	8	screw m 8 p.1.25 x 25

Section: ENGINE  
CASING COVER

Fig.	P/n	QTY	Name
------	-----	-----	------

Notes:  
[RUBIN 150]

30	0.065.1152.0	1	gasket
31	0.065.1151.0	1	cover
32	2.0112.205.2	2	screw m 8 p.1.25 x 16
34	2.0432.005.7	2	stud bolt m 8 p.1.5 / p.1 x 25

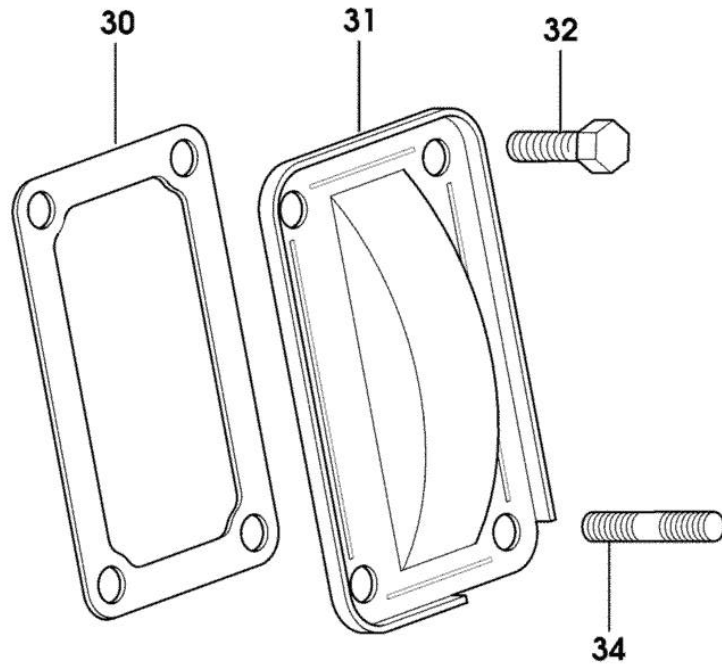

9\_33011\_04\_0\_0

Section: ENGINE  
**CRANKSHAFT**

Fig.	P/n	QTY	Name
------	-----	-----	------

Notes:  
 [RUBIN 150]

2	2.1651.915.0	1	pin 12x35
3	0.065.1215.0	7	main half bushing STANDARD
3	0.065.1215.7		main half bushing - mm 0.25
3	0.065.1215.8		main half bushing - mm 0.50
4	0.065.1216.0	7	main half bushing
4	0.065.1216.7		main half bushing - mm 0.25
4	0.065.1216.8		main half bushing - mm 0.50
5	0.065.1218.0	4	shim STANDARD
5	0.065.1218.7		shim + mm 0.10
5	0.065.1218.8		shim + mm 0.15
6	2.1599.524.7	1	washer 21x60x12
7	2.1720.006.0	1	key 4x6.5
9	0.065.1254.0/20	1	gasket
10	0.007.0851.0/10	1	cover
11	2.1529.073.0	1	special oil seal 110x130x13
12	2.1475.002.2	9	conical washer 8
13	2.0112.207.2	7	screw m 8 p 1.25 x 20
14	2.3130.001.1	6	plug 1/8" gas
15	2.1589.137.0	2	shoulder ring 71x110x1
16	2.0432.003.7	2	stud bolt m 8 p.1.25 / p.1 x 20
17	2.1011.105.2	2	nut m 8 p.1.25
20	0.009.3704.3	1	antivibration pulley
21	0.010.4320.3/20	1	crankshaft
21.2	0.007.0855.0/10	1	gear
22	0.011.2206.0/10	1	hub
23	2.0399.144.7/10	1	screw m 20 p.1.5x51

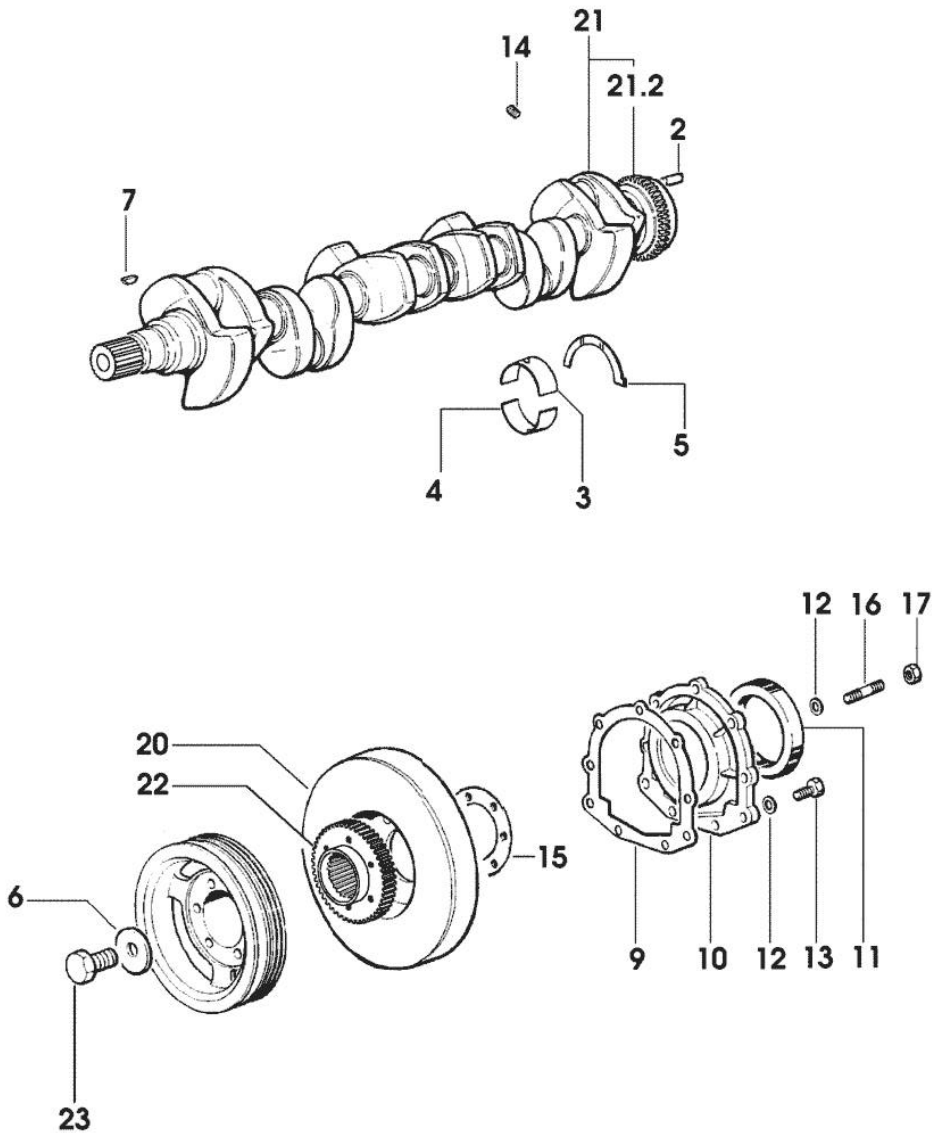

9\_37912\_00\_0\_0

Section: ENGINE

**CRANKSHAFT PULLEY**

Fig.	P/n	QTY	Name
------	-----	-----	------

**Notes:**

[RUBIN 150]

1	0.010.5449.0/10	1	pulley
2	2.0112.322.2	6	screw m 10 p.1.5x65
3	2.1470.006.2	6	lock washer 10
4	2.1589.137.0	2	shoulder ring 71x110x1

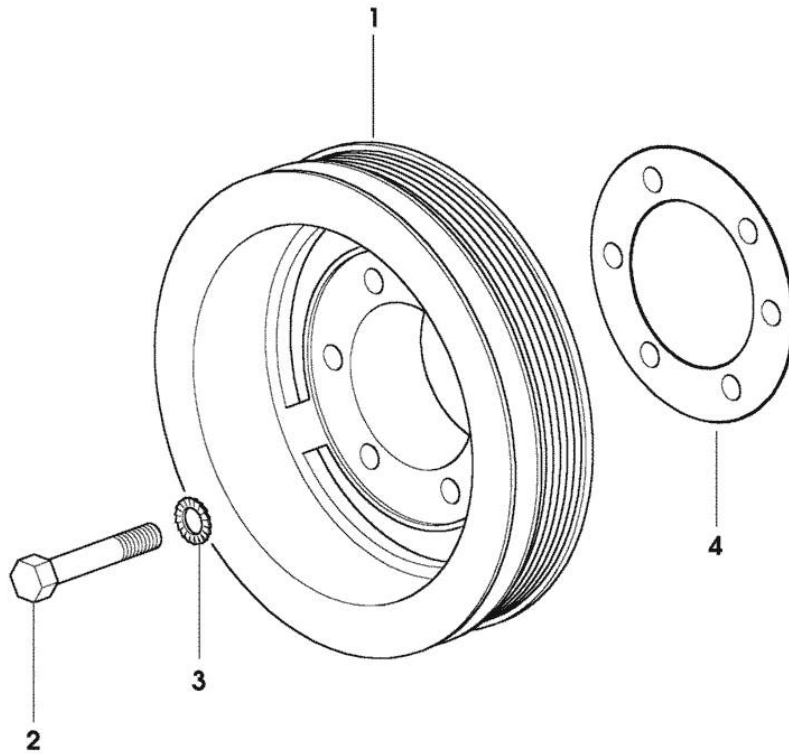

9\_38012\_01\_0\_0



**CYLINDER - PISTON - CONNECTING ROD**

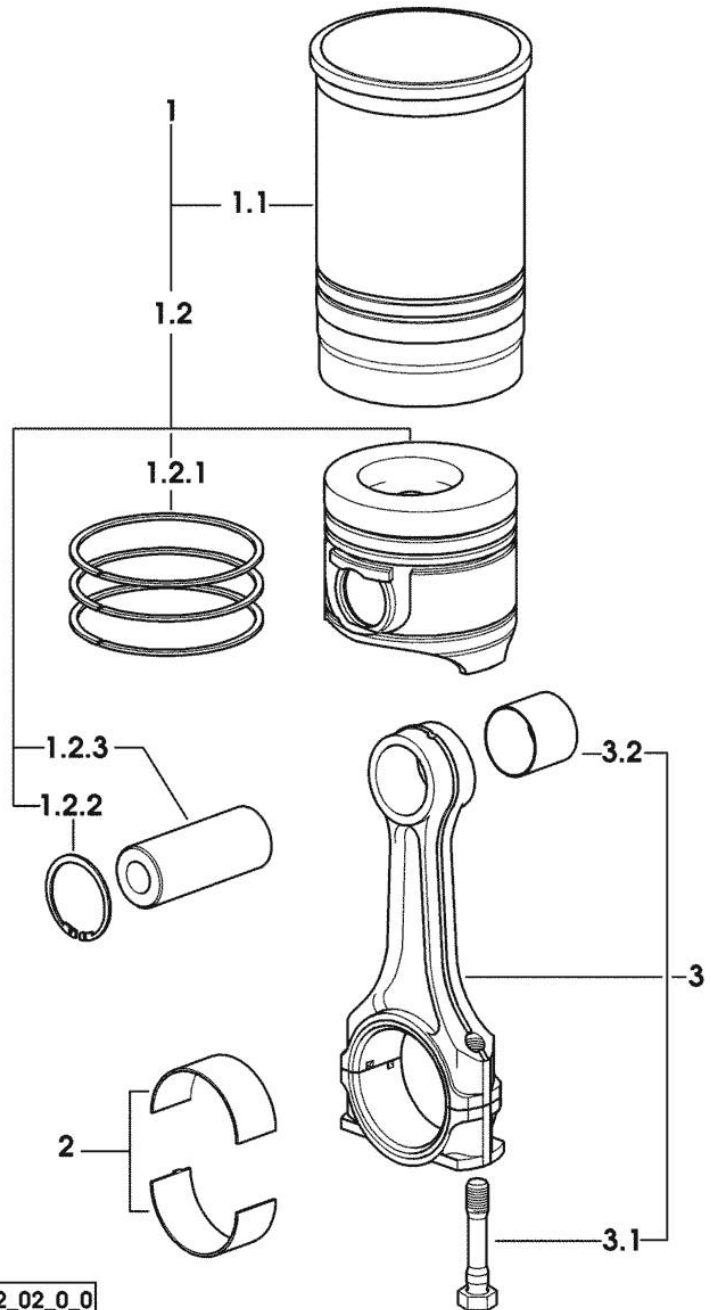

Fig.	P/n	QTY	Name
------	-----	-----	------

Notes:  
[RUBIN 150]

1	0.384.0065.A	6	cyl. piston assembly "A" - CLASS A
1	0.384.0065.B	6	cyl. piston assembly "B" - CLASS B
1.1	0.A12.2675.0	1	engine cylinder "A" - CLASS A
1.1	0.B12.2675.0	1	engine cylinder "B" - CLASS B
1.2	0.383.0060.A	1	complete piston "A" - CLASS A
1.2	0.383.0060.B	1	complete piston "B" - CLASS B
1.2.1	0.338.0052.6/20	1	piston ring set
1.2.2	2.1411.014.1	2	circlip 35
1.2.3	0.078.1236.0	1	piston pin Ø 18 / Ø 35 / L = mm 86
2	0.065.1225.0	12	con.rod half bushing STANDARD - A = 28.75 -> 29.00
2	0.065.1225.7	12	con.rod half bushing - mm 0.25
2	0.065.1225.8	12	con.rod half bushing - mm 0.50
3	0.007.1395.3/20	6	engine connecting rod
3.1	2.0399.213.0	2	screw m 12 p.1.25x61.5
3.2	2.1559.255.0	1	special bushing 34.60x39.130x34.65

9\_38312\_02\_0\_0

Section: ENGINE

**ENGINE FLYWHEEL**

Fig.	P/n	QTY	Name
------	-----	-----	------

Notes:  
[RUBIN 150]

1	0.007.0655.3/20	1	flywheel
1.2	0.065.1242.0	1	crown wheel Z = 123
2	2.0119.174.0/10	6	screw m 12 p.1.25x45

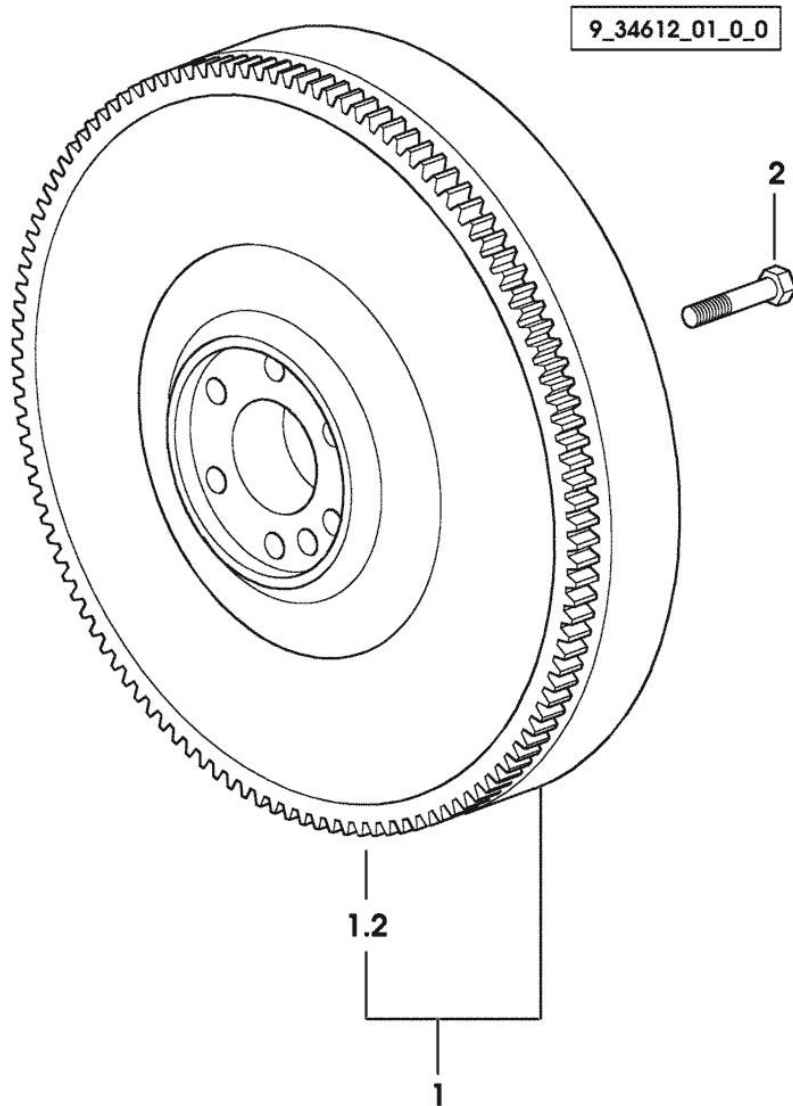

Section: ENGINE

**CAMSHAFT**

Fig.	P/n	QTY	Name
------	-----	-----	------

Notes:  
[RUBIN 150]

1	0.065.1331.2	12	rod
2	2.1569.114.0/10	24	gasket 14x18.5x8
3	0.065.1332.0	12	sleeve
4	2.4019.300.1/10	12	spring 18.5x52x2
5	2.1599.437.0	12	shoulder ring
6	0.065.1330.0	12	tappets
7	0.065.1354.0/20	1	gear z=58
8	2.0132.207.2	4	screw m 10 p.1 x 25
9	0.075.1310.3/30	1	camshaft
9.1	0.065.1324.0/10	1	gear Z = 32
10	0.065.1350.0	1	small disc
11	2.1410.016.1	1	circlip 40
12	0.065.1352.0	1	shim
13	0.065.1351.0	2	shoulder ring
14	0.007.1188.0/30	1	gear Z = 29
16	2.0312.205.2	2	screw
17	2.1480.014.1	2	washer 8
18	0.065.1353.0	1	small plate
19	0.007.1177.3/20		gear z = 57
			- WITH RED IDENTIFICATION STAMP
19.2	2.1559.185.0/10	1	bushing
20	0.007.1178.3/20		gear z = 57
			- WITH YELLOW IDENTIFICATION STAMP
20.2	2.1559.185.0/10	1	bushing
21	0.007.1179.3/20	1	gear z = 57
			- WITH GREEN IDENTIFICATION STAMP
21.2	2.1559.185.0/10	1	bushing
22	2.1559.398.0	1	bushing 10.5x13x12
			-> 1021 X RUBIN 150

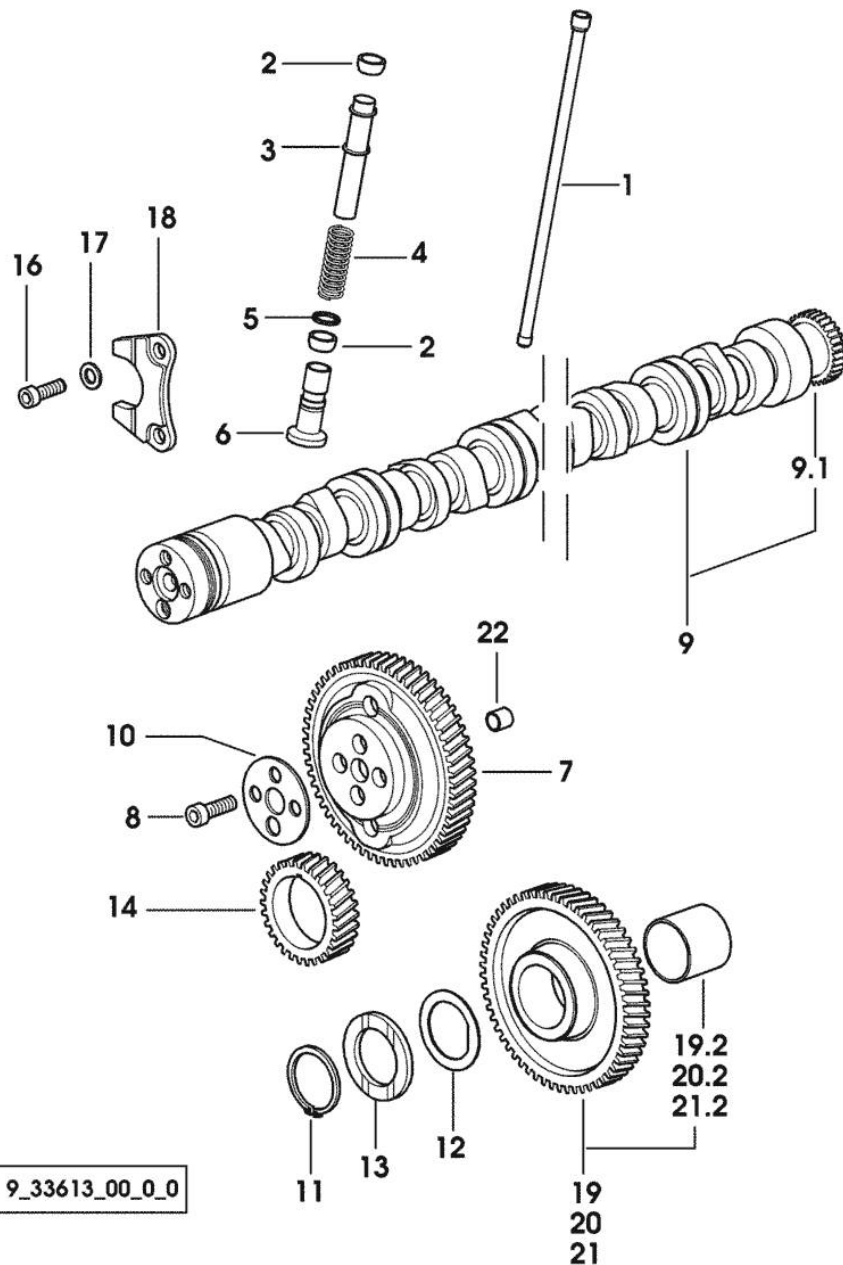

Section: ENGINE  
CYLINDER HEAD

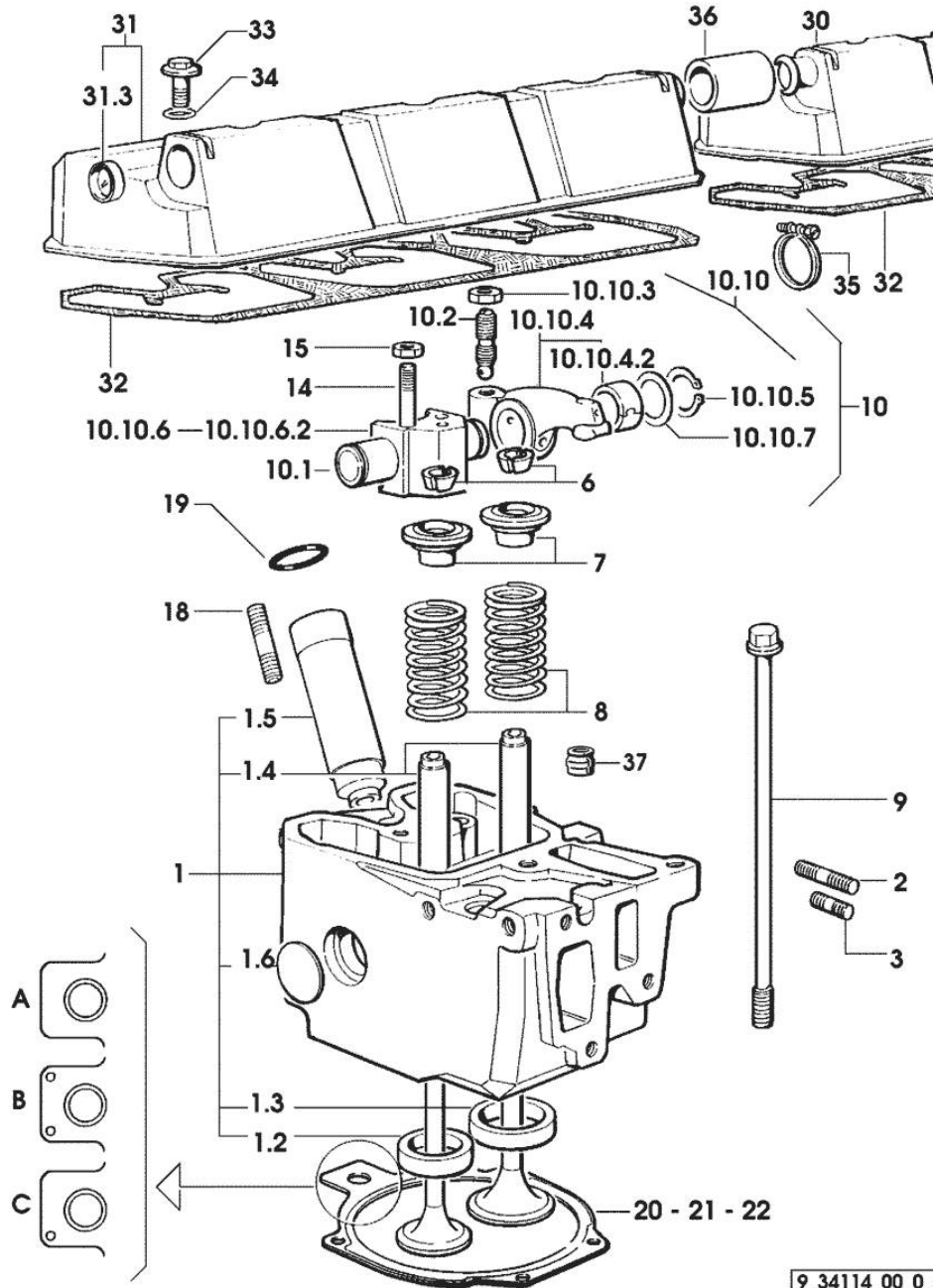

Fig.	P/n	QTY	Name
------	-----	-----	------

Notes:  
[RUBIN 150]

1	0.007.1360.3/60	6	head
1.2	0.078.1426.0	1	valve seat
1.3	0.066.1427.0	1	valve seat
1.4	0.007.1779.0/10	2	valve guide
1.5	0.010.6041.0	1	bush
1.6	2.3170.012.1	2	expansion plug 30
2	2.0432.011.7	6	stud bolt m 8 p.1.25 / p.1 x 40
3	2.0432.005.7	6	stud bolt m 8 p.1.5 / p.1 x 25
6	0.074.1423.0	24	conical valve cotter
7	0.066.1425.0	12	cup
8	2.4019.287.0	12	spring
9	0.012.2673.0	24	screw m 14 p.2x141 -> 1373 X RUBIN 135 -> 1397 X RUBIN 150
9	0.066.1443.0/10	24	screw 1372 <- X RUBIN 135 1396 <- X RUBIN 150
10	0.000.0000.1		cannot be supplied -> 1512 X RUBIN 135 -> 1577 X RUBIN 150
10.1	0.066.1431.0	1	pin
10.2	0.021.1434.0	2	screw
10.10	0.000.0000.1		cannot be supplied
10.10.3	2.1011.405.2	2	nut m 8 p.1
10.10.4	0.066.1432.3	2	rocker arm
10.10.4.2	2.1559.021.0/40	1	bushing 15x19x22
10.10.5	2.1410.055.7	2	circlip 19
10.10.6	0.000.0000.1		cannot be supplied
10.10.6.2	0.066.1430.0/10	1	support
10.10.7	2.1599.432.0	2	shoulder ring
14	2.0432.163.7	6	stud bolt m 10 p.1.5 / p.1.25 x 45
15	2.1011.421.2	12	nut m 10 p.1.25
18	2.0432.161.7	6	stud bolt m 10 p.1.5 / p.1.25 x 40
19	2.1530.051.0	6	oil seal 20.22x3.53
20	0.078.1451.0/40		head gasket -A-
21	0.078.1452.0/30		head gasket -B-
22	0.078.1453.0/40		head gasket -C-
30	0.078.1450.3	1	cover 1465 <- X RUBIN 135 1514 <- X RUBIN 150
30	0.078.1450.3/10	1	cover

Section: ENGINE  
CYLINDER HEAD

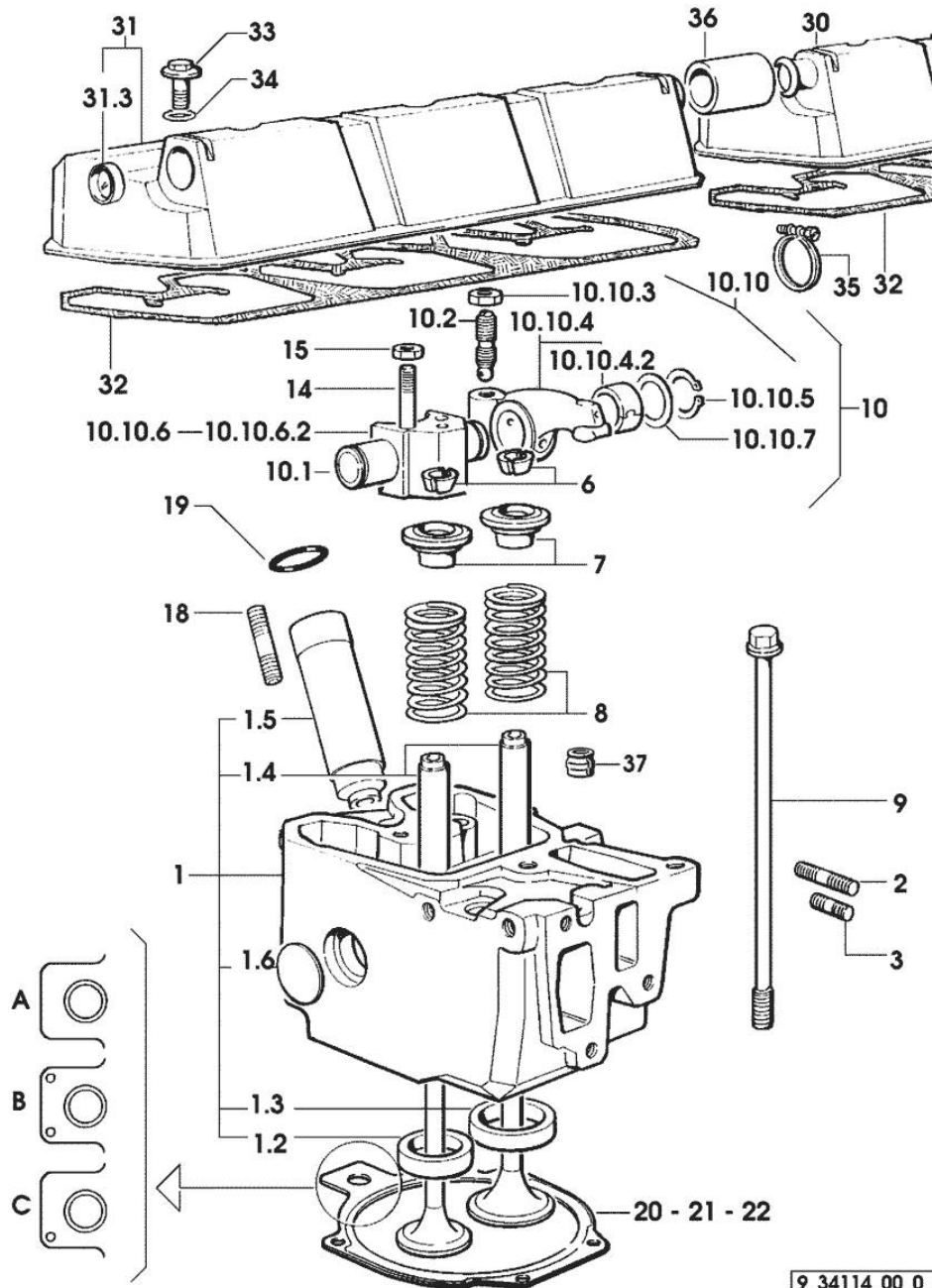

Fig.	P/n	QTY	Name
31	0.078.1440.3	1	-> 1466 X RUBIN 135 -> 1515 X RUBIN 150 cover
31	0.078.1440.3/10	1	cover -> 1466 X RUBIN 135 -> 1515 X RUBIN 150
31.3	2.3171.008.4	1	plug 20
32	0.009.3877.0/10	2	tappet gasket
33	2.0399.130.2/10	6	screw m 8x36x44 1465 <- X RUBIN 135 1514 <- X RUBIN 150
33	2.0399.288.2/10	6	screw m 8x36x46 -> 1466 X RUBIN 135 -> 1515 X RUBIN 150
34	2.1532.035.0	6	oil seal 14x1.78 1465 <- X RUBIN 135 1514 <- X RUBIN 150
34	2.1539.151.0	6	special oil seal 9.19 x 2.62 -> 1466 X RUBIN 135 -> 1515 X RUBIN 150
35	2.6859.091.0	2	clamp
36	0.075.1452.0/10	1	sleeve
37	2.1519.117.0	12	special oil seal

**INLET AND EXHAUST VALVES**

Fig.	P/n	QTY	Name
------	-----	-----	------

Notes:  
[RUBIN 150]

1	0.007.1147.0/10	6	exhaust valve mm 39.1 / Ø mm 9
2	0.007.1146.0/10	6	inlet valve mm 43.63 / Ø mm 9

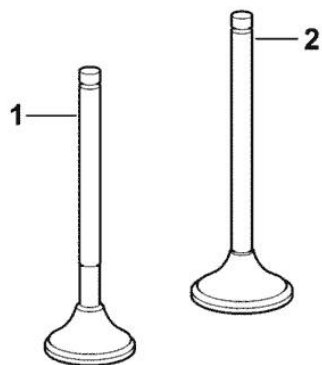

**OIL PAN - FOR TYPES WITHOUT SUSPENSION**

Fig.	P/n	QTY	Name
------	-----	-----	------

Notes:  
[RUBIN 150]

2	2.3199.001.2	2	plug 1/2" gas
3	2.1560.054.0	2	gasket 21 x 26
18	2.1470.004.2	34	lock washer 8
20	2.0112.215.2	25	screw m 8 p.1.25 x 40
21	0.010.9107.0/20	1	oil sump
22	2.0112.229.2	3	screw m 8 p.1.25 x 100
23	2.0112.235.2	2	screw m 8 p.1.25 x 130
24	2.0112.241.2	2	screw m 8 p.1.25 x 160
25	2.0112.243.2	2	screw m 8 p.1.25x170
26	2.1579.854.2	2	spacer 8.5x20x5

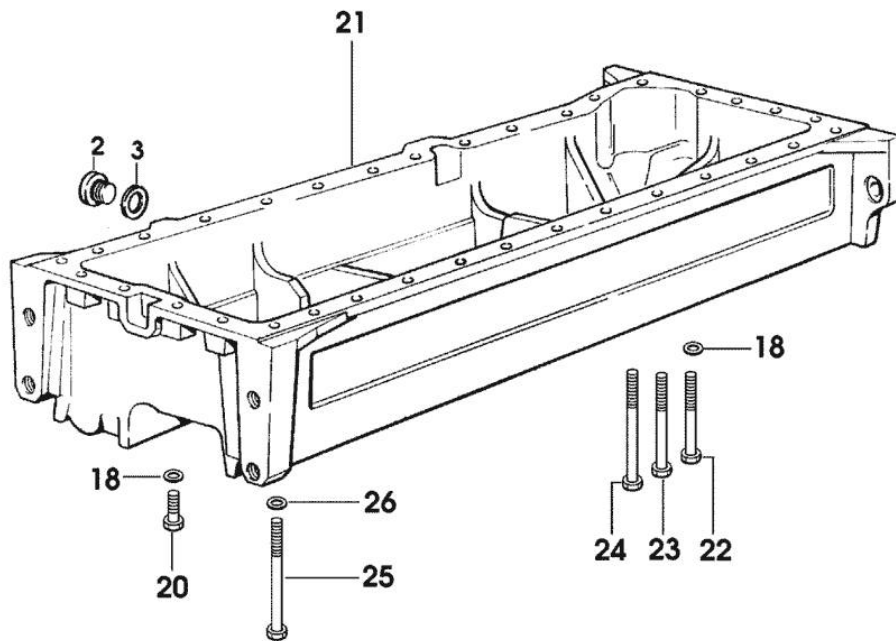

9\_38415\_02\_0\_0

Thank you so much for reading.  
Please click the “Buy Now!”  
button below to download the  
complete manual.



After you pay.

You can download the most  
perfect and complete manual in  
the world immediately.

Our support email:

[ebooklibonline@outlook.com](mailto:ebooklibonline@outlook.com)