

Section: ENGINE
CRANKCASE

Fig.	P/n	QTY	Name
------	-----	-----	------

Notes:
 [SILVER 90]

1	0.087.0050.6/10		gasket set - X SILVER 80 - 90 - 100.4 - FOR ENGINE MOUNTING
1	0.334.0050.6/10		gasket set - X SILVER 100.4 - ASSEMBLY OF ENGINE WITH MECHANICAL GOVERNOR
8	2.1099.108.2	4	special nut m 10 p.1
9	2.1560.006.0	8	gasket 10.2 x 16
10	0.086.1550.2	4	sprayer nozzle
11	0.065.1160.3/20	4	valve
12	2.1532.072.0	1	oil seal 26.70x1.78
13	2.3199.405.2	1	plug m 28 p.1.5
16	2.0432.003.7	12	stud bolt m 8 p.1.25 / p.1 x 20
19	2.1539.130.0/10	4	special oil seal 117.07x3.53
20	0.007.0762.0/50	4	engine cylinder
25	0.066.1152.0/10	4	gasket
26	0.007.1140.6/10	1	crankcase
27	0.065.1112.7	1	support
28	2.1699.165.0	1	bush 12.3x15x16
29	0.065.1116.3	1	support
30	2.1699.165.0	1	bush 12.3x15x16
31	0.066.1151.0	1	pin
32	0.065.1141.0	1	special bushing 59X55X30
33	0.065.1140.0	4	special bushing 59X55X20
34	2.3179.012.0	1	plug 60
35	2.3130.001.1	11	plug 1/8" gas
36	2.3130.002.1	2	plug 1/4" gas
37	2.3130.003.1	7	plug 3/8" gas
38	2.3199.092.0	4	plug 8 x 12
39	0.065.1114.0/10	3	support
40	0.065.1117.0	10	screw m 12 x 100
41	2.1324.011.0	1	plug
42	2.0112.511.1	8	screw m 14 p.2 x 30
43	0.007.1655.0	1	flange
44	2.1651.912.0	2	cylindrical plug 12x28
45	2.1651.917.0	1	cylindrical plug 12x40
46	2.0432.257.7	1	stud bolt m 12 p.1.75 - 1.25 x 30
47	2.0439.250.7	1	stud bolt m 12 / m 10 x 30
48	0.011.9294.0/10	1	bush
52	2.1560.017.0	1	gasket 22.2 x 27

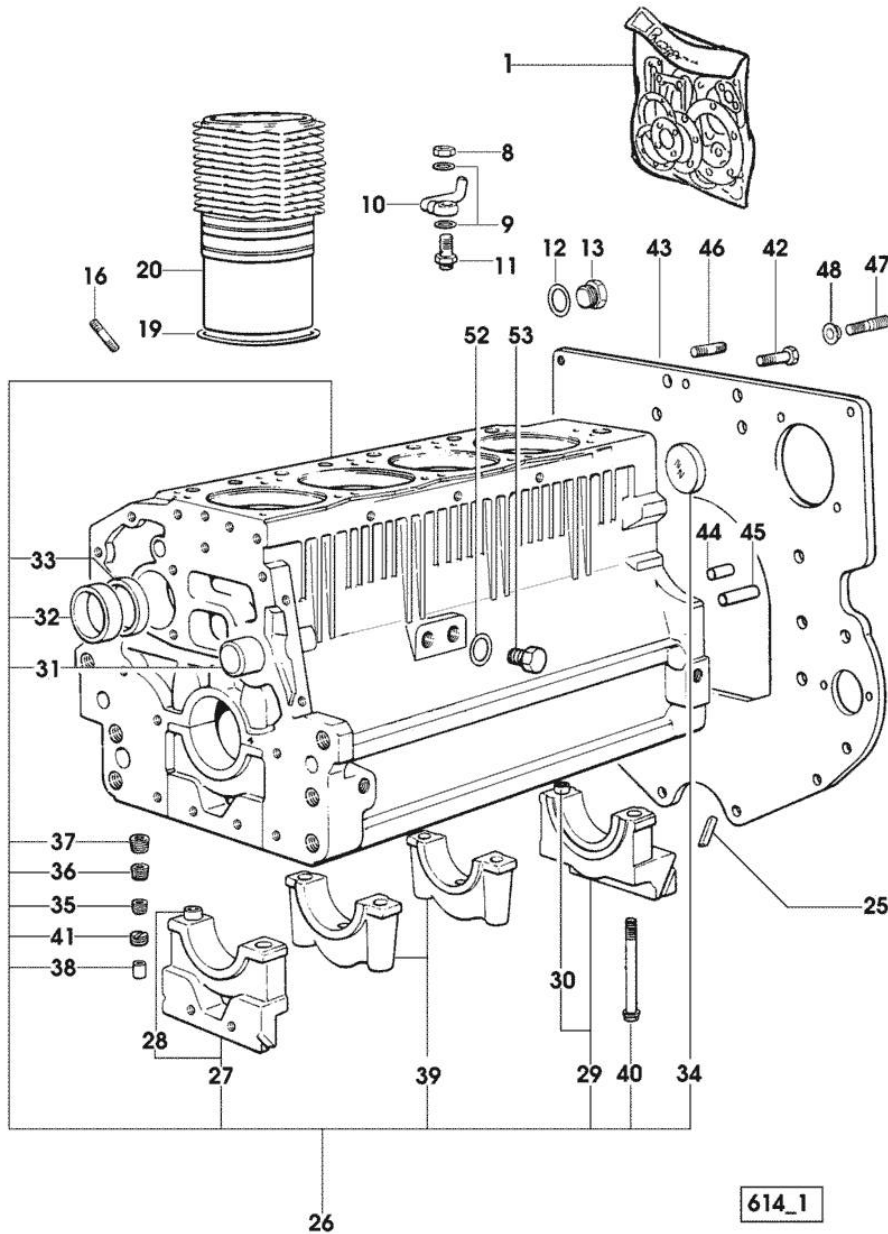

Section: ENGINE
CRANKCASE

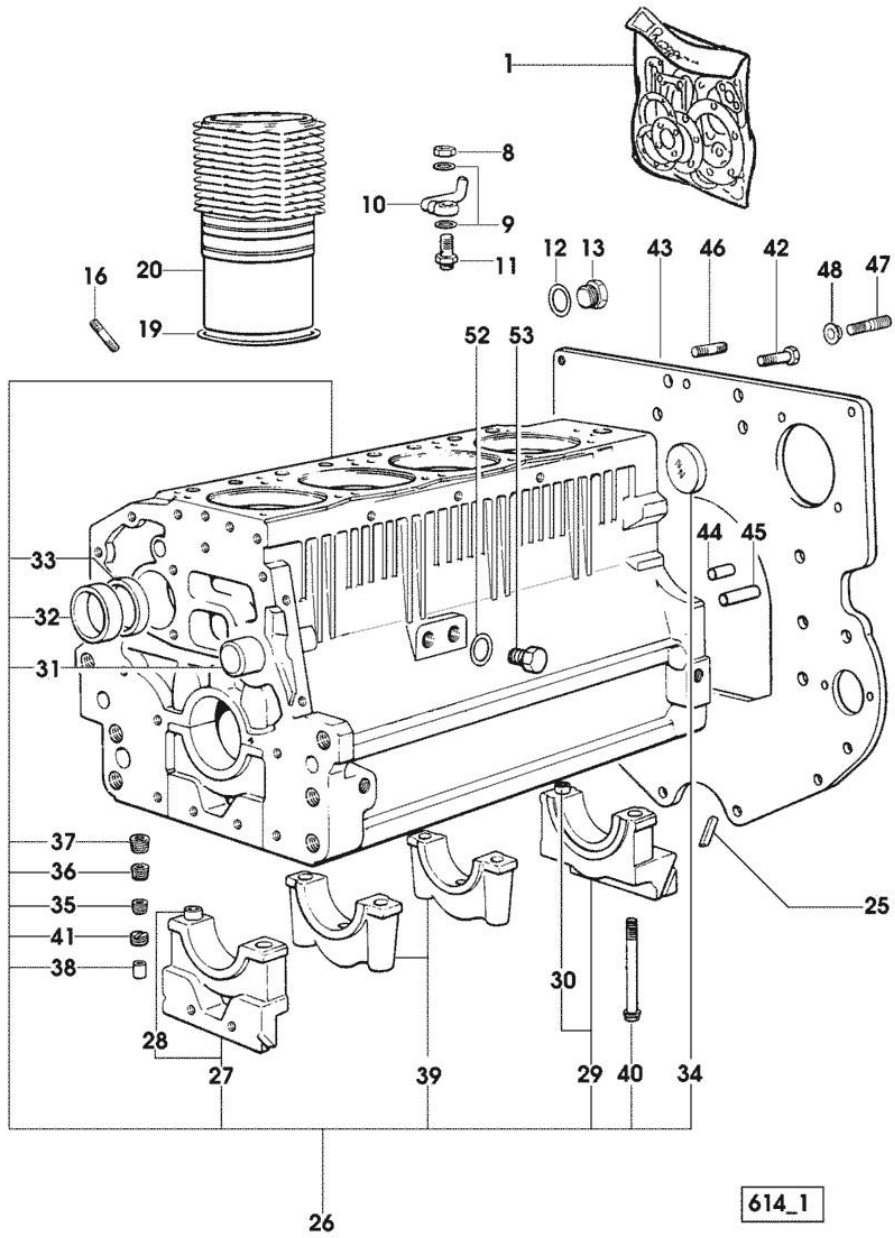

Fig.	P/n	QTY	Name
53	2.3120.002.4	1	- X SILVER 80 plug m 22 x 1.5 - X SILVER 80

614_1

Section: ENGINE

TIMING CASE

Fig.	P/n	QTY	Name
------	-----	-----	------

Notes:

[SILVER 90]

1	0.007.1262.3/50	1	guard
2	0.007.1271.0/10	1	small column m 8 p.1.25 / L = mm 60
3	0.007.1272.0/10	2	small column m 8 p.1.25 / L = mm 50
5	2.1310.004.2	3	flat washer 8.4x17
7	2.0112.205.2	3	screw m 8 p.1.25 x 16

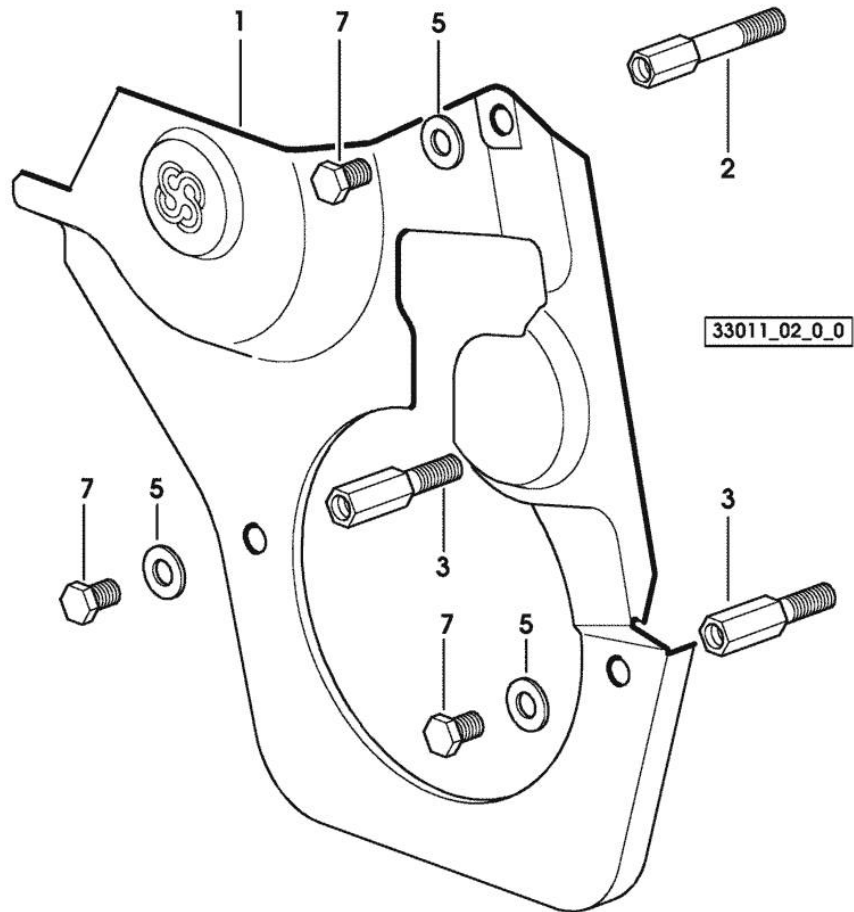

Section: ENGINE

TIMING CASE

Fig.	P/n	QTY	Name
------	-----	-----	------

Notes:

[SILVER 90]

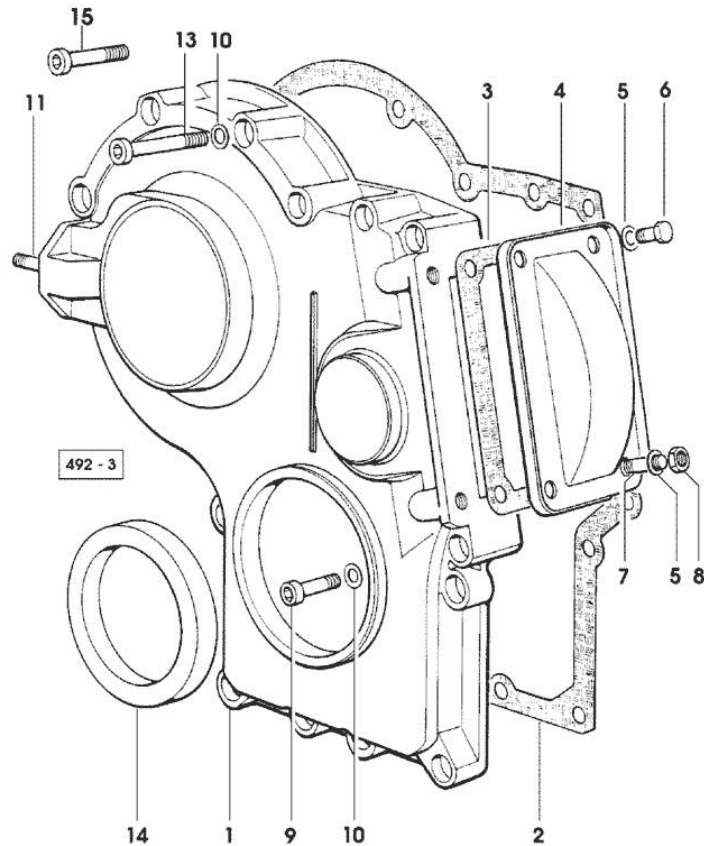

1	0.065.1132.0/60	1	guard
2	0.065.1150.0/30	1	gasket
3	0.065.1152.0	1	gasket
4	0.065.1151.0	1	cover
5	2.1470.004.2	4	lock washer 8
6	2.0112.205.2	2	screw m 8 p.1.25 x 16
7	2.0432.005.7	2	stud bolt m 8 p.1.5 / p.1 x 25
8	2.1011.405.2	2	nut m 8 p.1
9	2.0312.208.2	8	screw m 8 p.1.25 x 25
10	2.1480.014.1	15	washer 8
11	2.0432.003.7	2	stud bolt m 8 p.1.25 / p.1 x 20
13	2.0312.219.2	4	screw m 8 p.1.25x65
14	2.1529.141.0	1	special oil seal
15	2.0312.214.2	3	screw m 8 p.1.25 x 40

Section: ENGINE

CRANKSHAFT

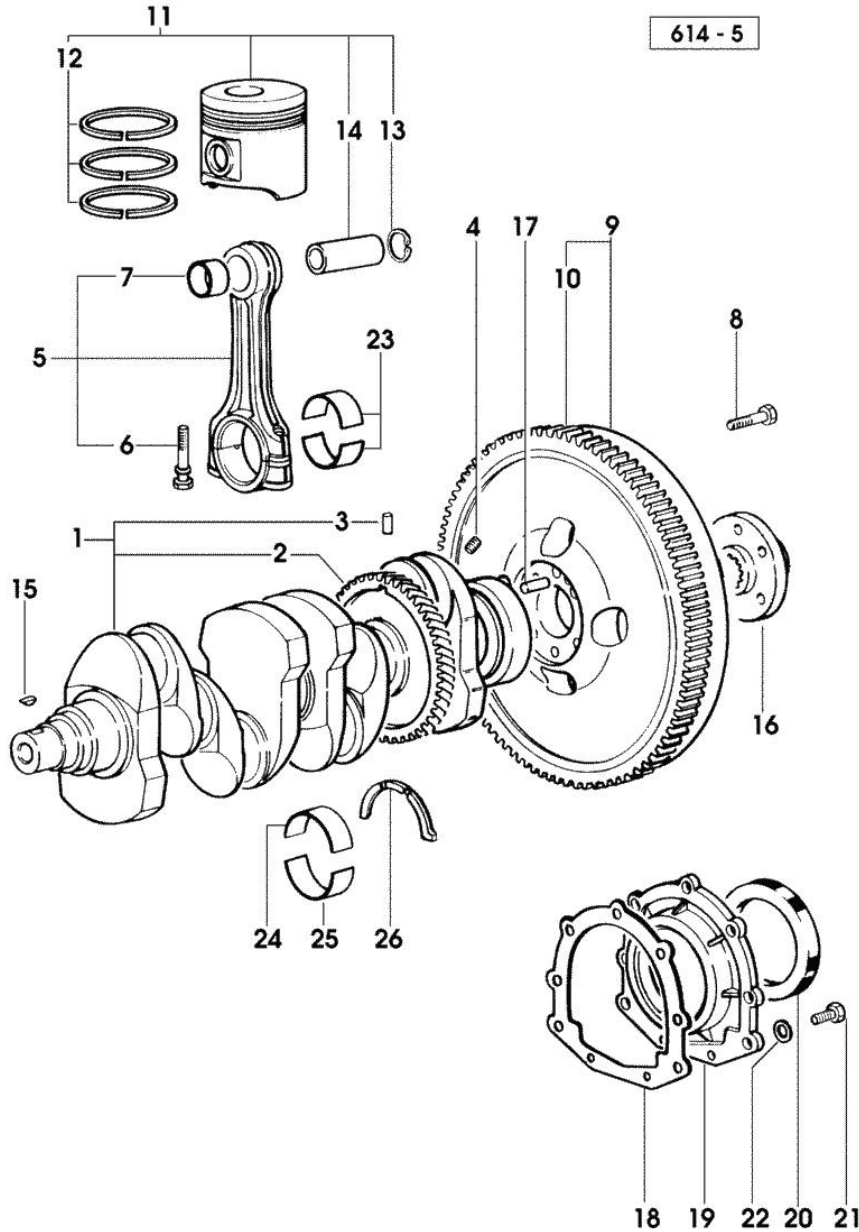

Fig.	P/n	QTY	Name
Notes:			
[SILVER 90]			
1	0.086.1210.3/30	1	crankshaft
2	0.065.1211.0/10	1	crown wheel
3	2.1630.608.0	1	pin 6x16
4	2.3130.001.1	4	plug 1/8" gas
5	0.078.1220.3/30	4	engine connecting rod
6	2.0399.213.0	2	screw m 12 p.1.25x61.5
7	2.1559.114.0/10	4	special bushing
8	2.0119.174.0/10	6	screw m 12 p.1.25x45 - X HYDRIVE
8	2.0139.022.2	6	screw m 12 p.1.25x55
9	0.007.1702.3/30	1	flywheel -> 2074 X SILVER 80 -> 2964 X SILVER 90 -> 1875 X SILVER 100.4
9	0.008.4049.3	1	flywheel mm 373 2073 <- X SILVER 80 2963 <- X SILVER 90 1874 <- X SILVER 100.4
9	0.010.7223.3/10	1	flywheel 2139 <- X SILVER 80 HYDRIVE 3042 <- X SILVER 90 HYDRIVE 1879 <- X SILVER 100.4 HYDRIVE
9	0.010.8727.3	1	flywheel -> 2140 X SILVER 80 HYDRIVE -> 3043 X SILVER 90 HYDRIVE -> 1880 X SILVER 100.4 HYDRIVE
10	0.065.1242.0	1	crown wheel Z = 123
11	0.086.0060.6/30	4	complete piston - X SILVER 80
11	0.338.0060.6/20	4	complete piston - X SILVER 90 - 100.4
11	0.379.0060.6	4	complete piston - X SILVER 80 - EXPORT U.S.A.
11	0.381.0060.6	4	complete piston - X SILVER 90 - 100.4 - EXPORT U.S.A.
12	0.086.0052.6/10	1	piston ring set - X SILVER 80
12	0.338.0052.6/10	1	piston ring set - X SILVER 90 - 100.4
13	2.1411.014.1	8	circlip 35
14	0.078.1236.0	4	piston pin Ø 18 / Ø 35 / L = mm 86

CRANKSHAFT

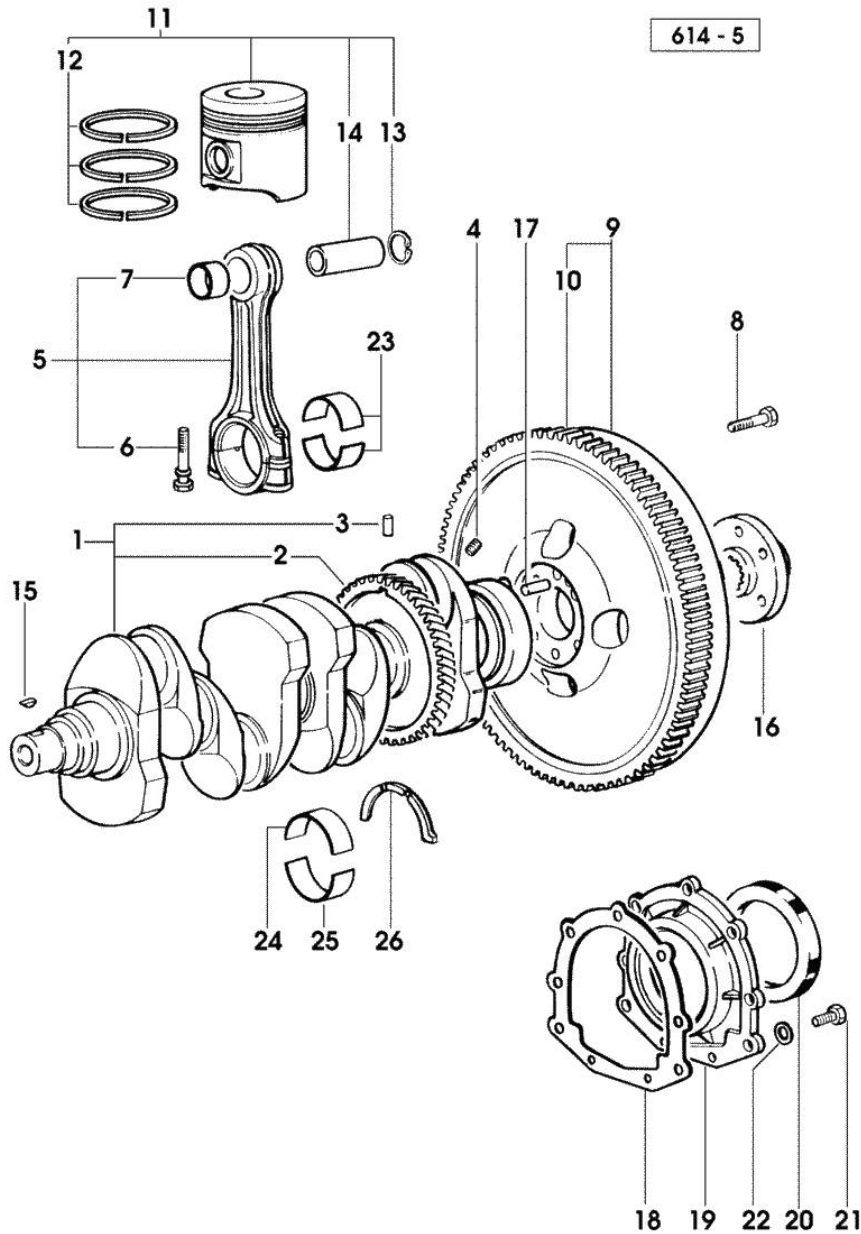

Fig.	P/n	QTY	Name
15	2.1720.006.0	1	key 4x6.5
16	0.008.5543.0	1	flange
17	2.1652.915.0	1	cylindrical plug 12x35
18	0.065.1254.0/20	1	gasket
19	0.007.1711.0/10	1	cover
20	2.1529.073.0	1	special oil seal 110x130x13
21	2.0112.207.2	9	screw m 8 p 1.25 x 20
22	2.1475.002.3	9	washer 8
23	0.065.1225.0	8	con.rod half bushing STANDARD - A = 28.75 -> 29.00
23	0.065.1225.7		con.rod half bushing - mm 0.25
23	0.065.1225.8		con.rod half bushing - mm 0.50
24	0.065.1215.0	5	main half bushing STANDARD
24	0.065.1215.7		main half bushing - mm 0.25
24	0.065.1215.8		main half bushing - mm 0.50
25	0.065.1216.0	5	main half bushing
25	0.065.1216.7		main half bushing - mm 0.25
25	0.065.1216.8		main half bushing - mm 0.50
26	0.065.1218.0	4	shim STANDARD
26	0.065.1218.7		shim + mm 0.10
26	0.065.1218.8		shim + mm 0.15

Section: ENGINE

ENGINE SHAFT - PULLEYS

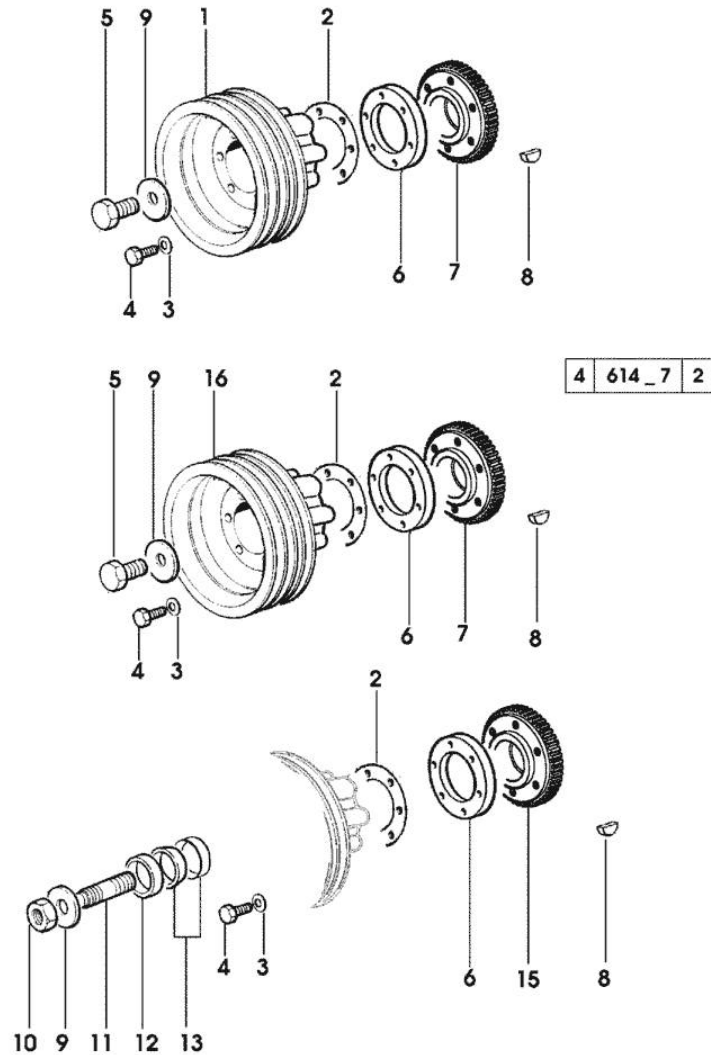

Fig.	P/n	QTY	Name
Notes:			
[SILVER 90]			
1	0.007.6161.0	1	pulley * 1097 <= X SILVER 80 * 1159 <= X SILVER 90 * 1069 <= X SILVER 100.4 - N.1 - 007.6816.0
2	2.1589.136.0	2	shoulder ring 71x110x0.5
2	2.1589.137.0	2	shoulder ring 71x110x1
3	2.1470.006.2	6	lock washer 10
4	2.0112.322.2	6	screw m 10 p.1.5x65
5	2.0399.144.7/10	1	screw m 20 p.1.5x51
6	0.007.1645.0	1	spacer 2299 <- X SILVER 80 3775 <- X SILVER 90 2076 <- X SILVER 100.4
7	0.011.3512.0/10	1	hub
8	2.1720.006.0	1	key 4x6.5
9	2.1599.524.7	2	washer 21x60x12
10	2.1019.094.7	1	nut m 20 p.1.5
11	2.0439.195.7	1	stud bolt m 20 p.1.5x80
12	2.1579.865.0	1	spacer 45.2x51.8x10
13	0.065.1256.0	2	ring 45x52
15	0.011.3510.0/10	1	hub
16	0.007.6161.0	1	pulley - FOR ACCESSORIES

Section: ENGINE
COUNTERWEIGHTS

Fig.	P/n	QTY	Name
------	-----	-----	------

Notes:
 [SILVER 90]

1	0.086.1233.3/30	1	mass sx/lh/li
2	2.1559.115.0	2	special bushing 26x30x30
3	2.1652.302.0	1	roll pin 4x6
4	0.000.0000.1		cannot be supplied
5	0.065.1233.3/30	1	mass dx/rh/re
6	2.1410.018.1	1	circlip 45
7	2.1652.302.0	1	roll pin 4x6
8	2.1559.115.0	2	special bushing 26x30x30
9	0.000.0000.1		cannot be supplied
10	2.1589.185.0	4	shoulder ring 26.1x34x1
11	2.1631.717.0	2	roll pin 8 x 40
12	0.086.1231.0/10	1	box
13	2.3130.001.1	4	plug 1/8" gas
14	2.0139.028.2	4	screw m 12
15	2.1579.628.0	3	spacer 16.5x26x0.1
15	2.1589.048.0	1	shoulder ring 16.5x26x0.3
16	2.1579.629.0	4	spacer 12.5x26x0.1
16	2.1589.049.0	2	shoulder ring 12.5x26x0.3
17	2.1579.626.0	2	spacer 13.2x16x11
18	2.1589.139.0	1	shoulder ring mm 0.3
19	2.1589.140.0	3	shoulder ring mm 0.1
20	2.1699.191.0	1	bush 7x10x16
21	0.065.1234.0/10	2	shaft
22	2.3130.001.1	1	plug 1/8" gas

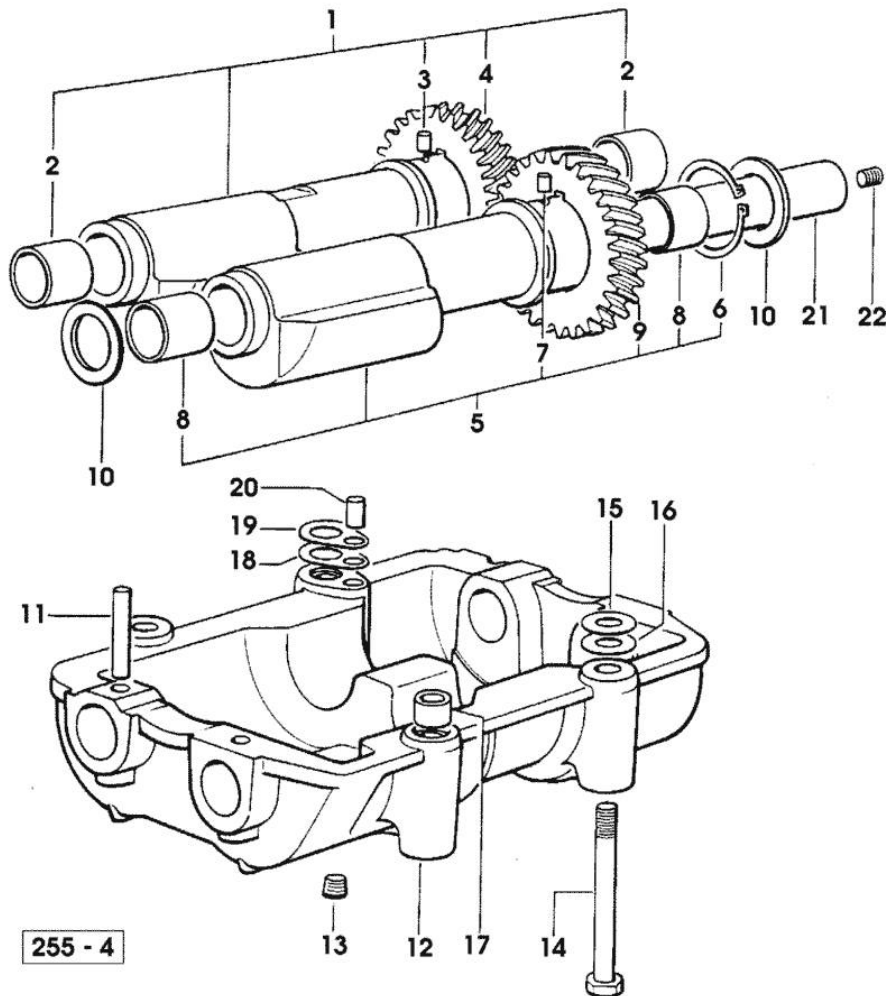

Section: ENGINE

CAMSHAFT

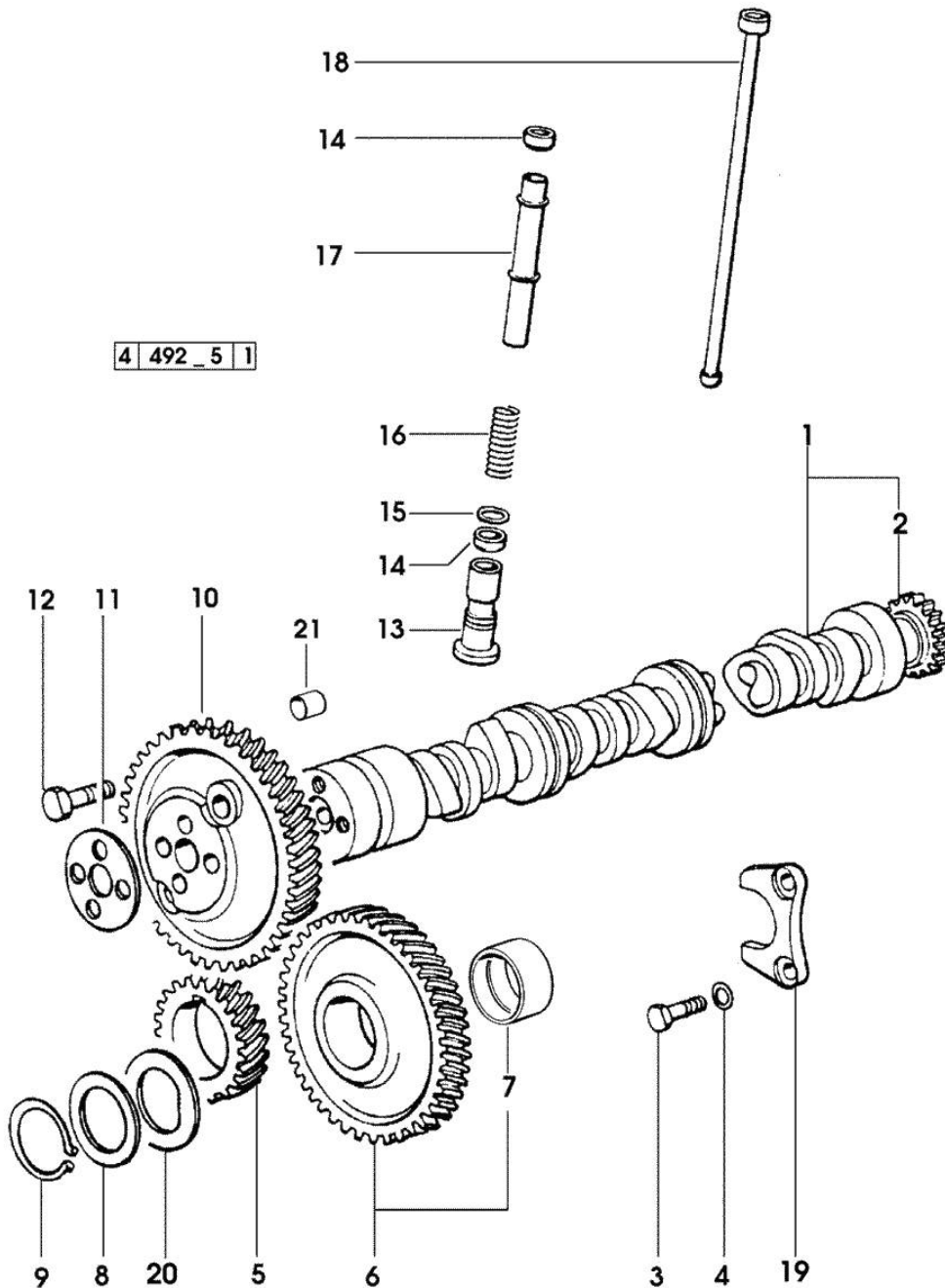

Fig.	P/n	QTY	Name
------	-----	-----	------

Notes:
[SILVER 90]

1	0.007.1712.3/10	1	camshaft - EXPORT U.S.A.
1	0.066.1310.3/40	1	camshaft
2	0.065.1324.0/10	1	gear Z = 32
3	2.0312.206.2	2	screw m 8 p 1.25 x 20
4	2.1480.014.1	2	washer 8
5	0.065.1323.0/30	1	gear Z = 29
6	0.007.1177.3/10	1	gear z = 57 - WITH RED IDENTIFICATION STAMP
6	0.007.1178.3/10	1	gear z = 57 - WITH YELLOW IDENTIFICATION STAMP
6	0.007.1179.3/10	1	gear z = 57 - WITH GREEN IDENTIFICATION STAMP
7	2.1559.185.0/10	1	bushing
8	0.065.1352.0	1	shim
9	2.1410.016.1	1	circlip 40
10	0.065.1354.0/20	1	gear z=58
11	0.065.1350.0	1	small disc
12	2.0132.207.2	4	screw m 10 p.1 x 25
13	0.065.1330.0	8	tappets
14	2.1569.114.0/10	16	gasket 14x18.5x8
15	2.1599.437.0	8	shoulder ring
16	2.4019.300.1/10	8	spring 18.5x52x2
17	0.065.1332.0	8	sleeve
18	0.065.1331.2	8	rod
19	0.065.1353.0	1	small plate
20	0.065.1351.0	2	shoulder ring
21	2.1559.398.0	1	bushing 10.5x13x12

Section: ENGINE
CYLINDER HEAD

Fig.	P/n	QTY	Name
------	-----	-----	------

Notes:
[SILVER 90]

1	2.0399.130.2/10	4	screw m 8x36x44
2	2.1569.170.0/10	4	gasket 8.2 x 14
3	0.007.1139.0/10	4	small cap
4	0.065.1450.0/30	1	tappet gasket
5	2.1011.421.2	8	nut m 10 p.1.25
6	2.0432.163.7	8	stud bolt m 10 p.1.5 / p.1.25 x 45
7	0.066.1430.0/10	4	support
8	0.066.1432.3	8	rocker arm
9	2.1559.021.0/40	8	bushing 15x19x22
10	2.1410.055.1	8	circlip 19
11	2.1011.405.2	8	nut m 8 p.1
12	0.021.1434.0	8	screw
13	0.074.1423.0	16	conical valve cotter
14	0.066.1425.0	8	cup
15	2.4019.287.0	8	spring
16	0.007.1122.0/10	4	bush L = mm 6.4
17	2.0432.161.7	4	stud bolt m 10 p.1.5 / p.1.25 x 40
18	0.065.1443.0/20	16	screw
20	2.0432.007.2	8	stud bolt m 8 p.1.25 / p.1 x 30
21	0.085.1450.0		head gasket mm 0.5 -A-
21	0.085.1451.0		head gasket mm 0.7 -B-
21	0.085.1452.0		head gasket mm 1.0 -C-
21	0.085.1453.0		head gasket mm 0.8 -D-
22	0.010.6022.0	4	exhaust valve mm 39.1 / Ø mm 9 - X SILVER 90 - 100.4 -> (...) = B
22	0.066.1421.0	4	exhaust valve - X SILVER 80 - X SILVER 90 - 100.4 (...) <- = A
23	0.010.6016.0	4	inlet valve mm 43.63 / Ø mm 9 - X SILVER 80
23	0.010.6017.0	4	inlet valve mm 43.63 / Ø mm 9 - X SILVER 90 - 100.4 -> (...) = B
23	0.081.1420.0	4	inlet valve Ø mm 9 - X SILVER 90 - 100.4 (...) <- = A
24	0.007.1110.3/50	4	engine head - X SILVER 80 - X SILVER 90 - 100.4 (...) <- = A
24	0.007.1359.3/50	4	engine head - X SILVER 90 - 100.4 -> (...) = B
25	0.066.1427.0	4	valve seat
26	0.078.1426.0	4	valve seat

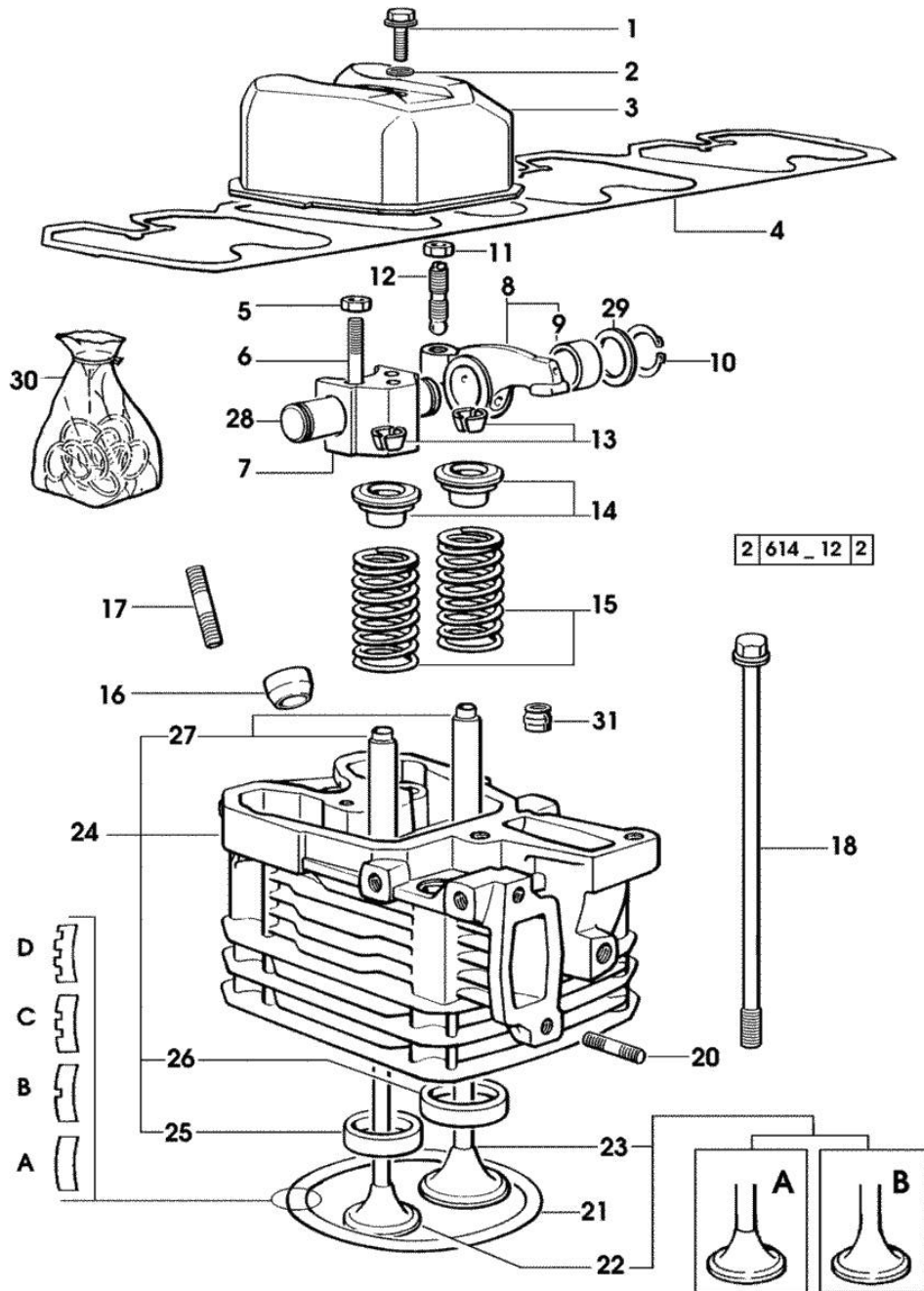

Thank you so much for reading.
Please click the “Buy Now!”
button below to download the
complete manual.



After you pay.

You can download the most
perfect and complete manual in
the world immediately.

Our support email:

ebooklibonline@outlook.com