

OIL SUCTION

Fig.	P/n	QTY	Name
------	-----	-----	------

Notes:

VERSION WITH 2 HYDRAULIC PUMPS [SILVER³ 100 -> 10001 / 15001]

1	2.0112.204.2	3	screw m 8 p.1.25x14
2	2.1312.004.3	2	washer 8,4x24x2
3	0.013.8789.0/10	1	cover
4	2.1530.157.0	1	oil seal 64.77x2.62
5	2.4419.484.0	1	oil filter
6	2.1532.138.0	1	oil seal 55.56x3.53
7	0.015.6599.3	1	tube
8	2.1310.004.2	3	flat washer 8.4x17
9	2.0112.209.2	3	screw m 8 p 1.25 x 25
10	2.6851.004.0	4	clamp Ø 32/50
11	2.3213.240.0	1	sleeve
12	2.3213.234.0	1	sleeve Ø 34, L 70
13	0.9104.250.0/10	2	gasket
15	2.1560.004.0	1	copper gasket 8.2 x 14

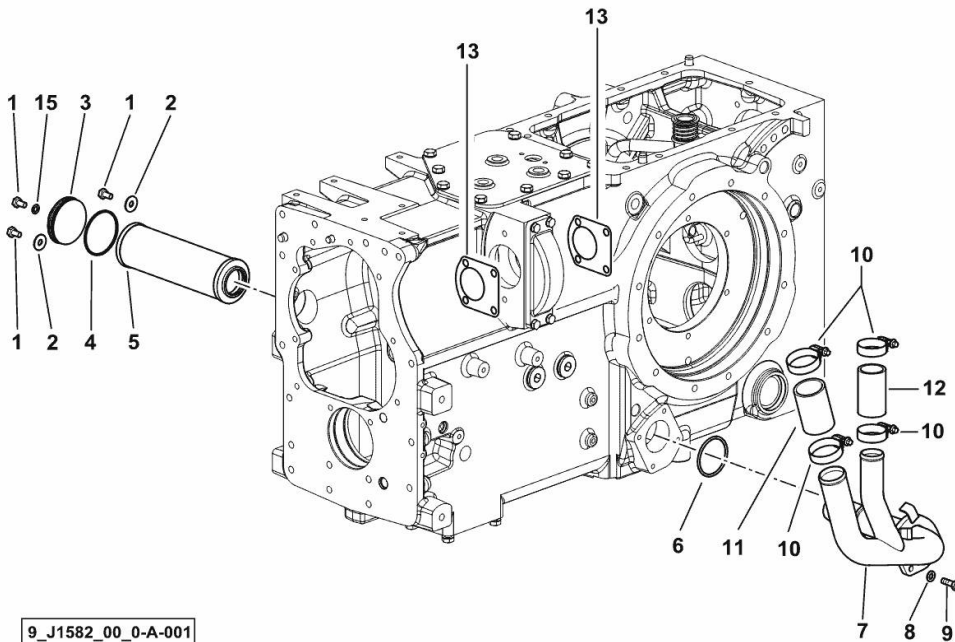

9_J1582_00_0-A-001

OIL SUCTION

Fig.	P/n	QTY	Name
------	-----	-----	------

Notes:

VERSION WITH 3 HYDRAULIC PUMPS [SILVER³ 100 -> 10001 / 15001]

1	2.0112.204.2	3	screw m 8 p.1.25x14
2	2.1312.004.3	2	washer 8,4x24x2
3	0.013.8789.0/10	1	cover
4	2.1530.157.0	1	oil seal 64.77x2.62
5	2.4419.795.0	1	hydr.oil filter elem.
6	2.1532.138.0	1	oil seal 55.56x3.53
7	0.017.5872.3	1	tube
8	2.1310.004.2	3	flat washer 8.4x17
9	2.0112.209.2	3	screw m 8 p 1.25 x 25
10	2.6851.004.0	4	clamp Ø 32/50
11	2.3213.240.0	1	sleeve
12	2.3213.234.0	2	sleeve Ø 34, L 70
13	0.9104.250.0/10	3	gasket
15	2.1560.004.0	1	copper gasket 8.2 x 14

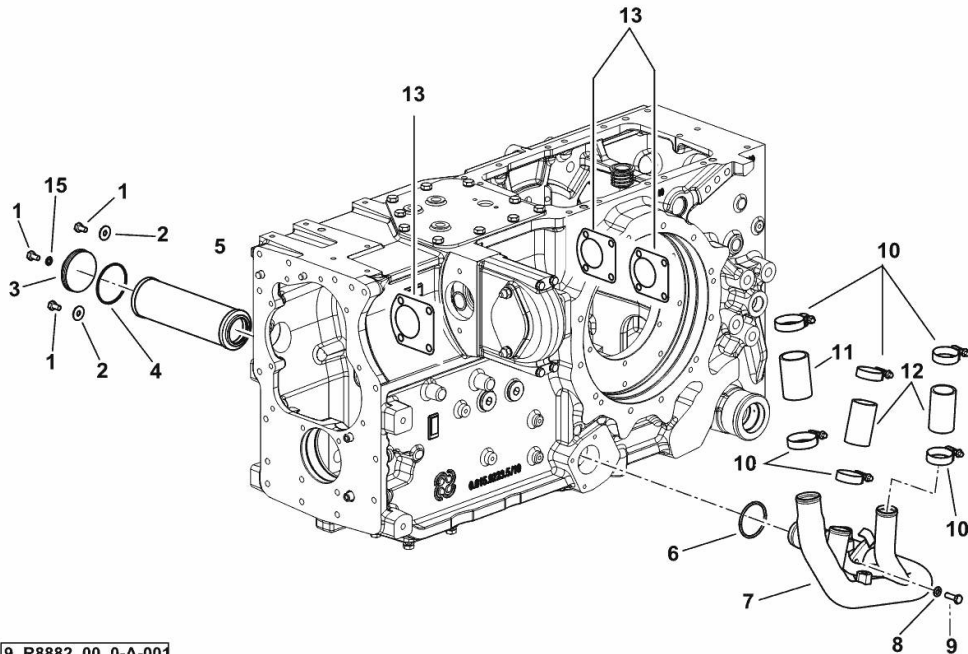

9_R8882_00_0-A-001

OIL FILTER

Fig.	P/n	QTY	Name
------	-----	-----	------

Notes:

[SILVER³ 100 -> 10001 / 15001]

1	2.4419.490.0/30	1	filter 8 " 40 bar ☞ 2.4419.490.0/30
4	0.017.5334.2	1	bracket
5	2.0112.205.2	2	screw m 8 p.1.25 x 16
6	2.1310.004.2	7	flat washer 8.4x17
7	2.0432.005.7	1	stud bolt m 8 p.1.5 / p.1 x 25
8	2.0432.003.7	3	stud bolt m 8 p.1.25 / p.1 x 20
9	2.1011.505.2	5	nut m 8 p.1
10	0.011.0481.2/20	1	guard
11	2.0342.303.6	1	screw m 8 p. 1.25x16

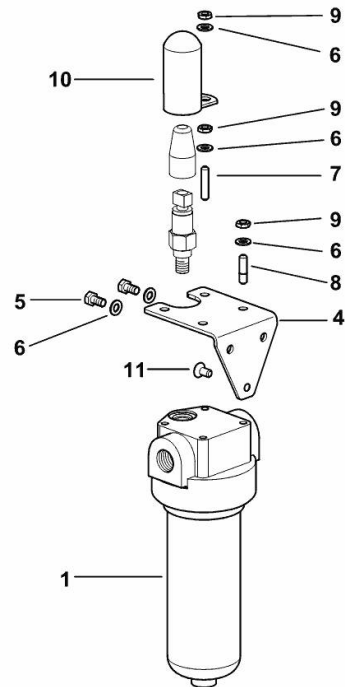

9_R8582_10_0-A-001

POWER STEERING OIL FEED HYDRAULIC SYSTEM

Fig.	P/n	QTY	Name
------	-----	-----	------

Notes:

VERSION WITH 2 HYDRAULIC PUMPS [SILVER³ 100 -> 10001 / 15001]

1	2.0312.106.2	2	screw m 6 p.1 x 20
2	2.1480.012.2	4	washer 6, d128
3	0.012.7294.0/10	1	flange
4	2.1531.052.0	1	oil seal 20.29 x 2.62
5	0.015.1445.3/20	1	tube
6	0.015.1446.2/20	1	bracket
7	2.3249.141.2	1	pipe fitting 7/8 JIC-M18
8	0.164.8157.3/20	2	fascia Ø 97
9	0.018.3694.0	1	vibration damper OGNIBENE
10	2.0112.305.2	2	screw m 10 p.1.5 x 16
11	2.1475.003.2	2	washer 10
12	2.0312.115.2	2	screw m 6 p.1x45
13	2.3249.418.2	1	pipe fitting m 18 x 1,5

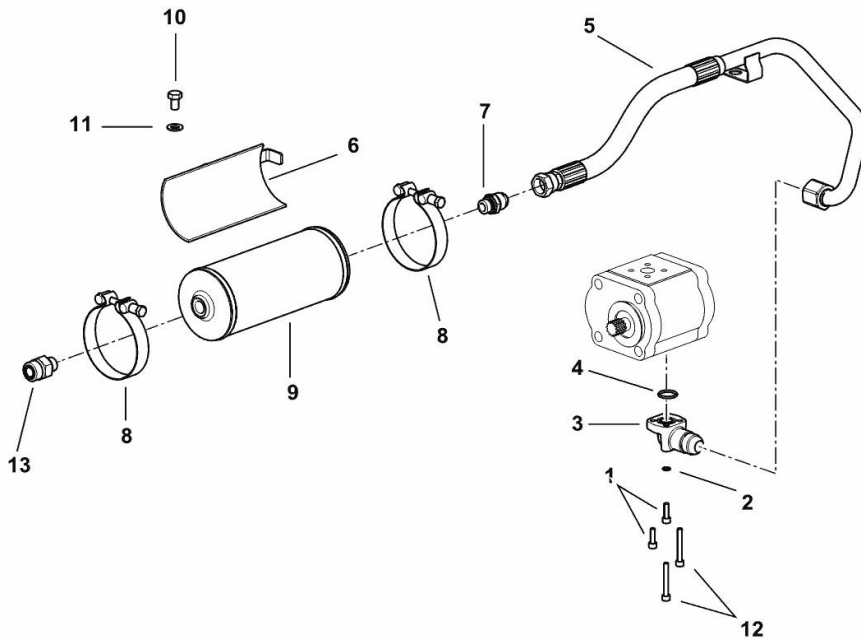

9_R8882_06_0-A-001

POWER STEERING OIL FEED HYDRAULIC SYSTEM

Fig.	P/n	QTY	Name
------	-----	-----	------

Notes:

VERSION WITH 3 HYDRAULIC PUMPS [SILVER³ 100 -> 10001 / 15001]

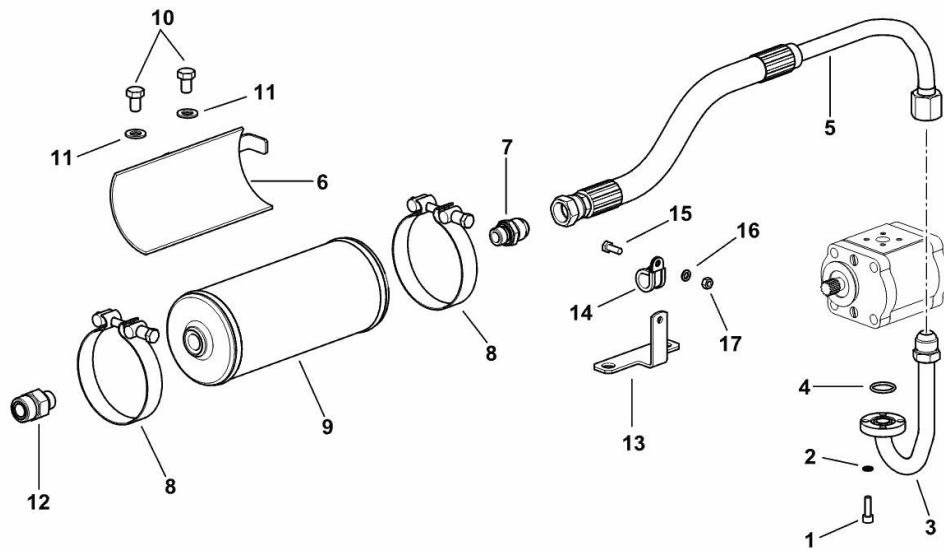

1	2.0312.106.2	4	screw m 6 p.1 x 20
2	2.1480.012.2	4	washer 6, d128
3	0.017.5852.3	1	tube
4	2.1531.052.0	1	oil seal 20.29 x 2.62
5	0.017.5805.3	1	tube
6	0.015.1446.2/20	1	bracket
7	2.3249.141.2	1	pipe fitting 7/8 JIC-M18
8	0.164.8157.3/20	2	fascia Ø 97
9	0.018.3694.0	1	vibration damper OGNIBENE
10	2.0112.305.2	2	screw m 10 p.1.5 x 16
11	2.1475.003.2	2	washer 10
12	2.3249.418.2	1	pipe fitting m 18 x 1,5
13	0.017.9694.0	1	bracket
14	2.6839.066.0/10	1	clamp 16
15	2.0112.005.2	1	screw m 6 p.1 x 16
16	2.1470.002.2	1	lock washer 6
17	2.1011.103.2	1	nut m 6 p.1

OIL TRANSFER PUMP HYDRAULIC SYSTEM

Fig.	P/n	QTY	Name
------	-----	-----	------

Notes:

[SILVER³ 100 -> 10001 / 15001]

1	2.1531.091.0	1	oil seal 34.60 x 2.62
2	0.015.6619.3	1	tube
3	2.1470.004.2	2	lock washer 8
4	2.0112.215.2	2	screw m 8 p.1.25 x 40
5	2.6851.004.0	2	clamp Ø 32/50
6	2.3213.228.0	1	sleeve
7	0.015.6617.3	1	tube
8	2.1531.062.0	1	oil seal 23.81 x 2.62
9	2.0312.206.2	2	screw m 8 p 1.25 x 20
10	2.1480.014.2	2	washer 8
11	2.1560.018.0	2	gasket 22.2 x 29
12	2.3335.009.2	1	pipe union m 22 p.1.5 x 39
13	0.015.1335.3	1	tube
14	2.3249.141.2	1	pipe fitting 7/8 JIC-M18

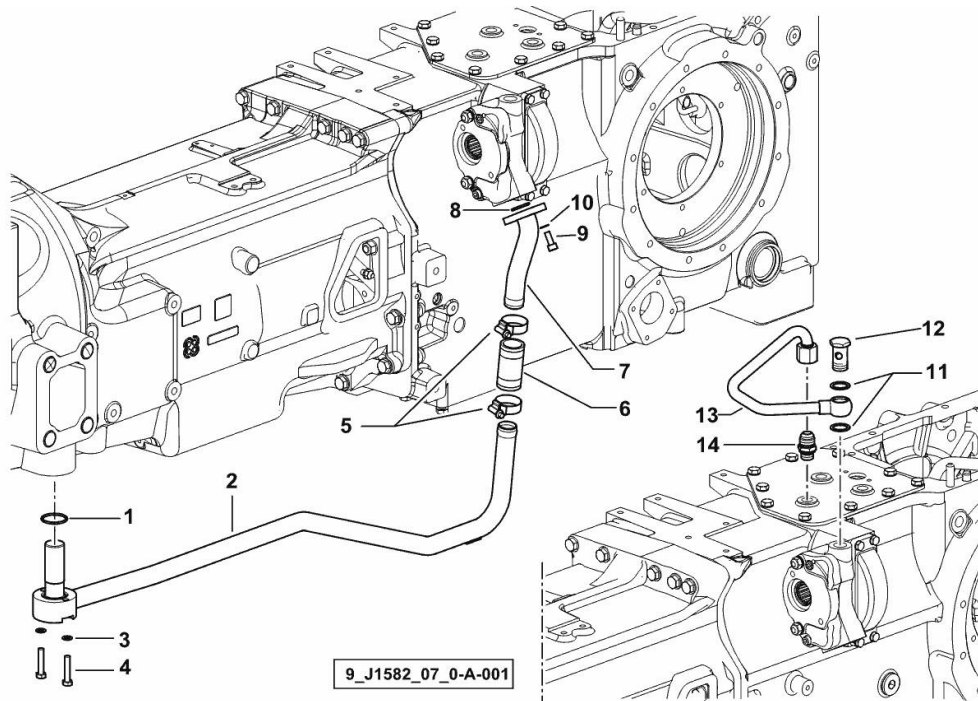

OIL CONTROL VALVES HOUSING PIPES

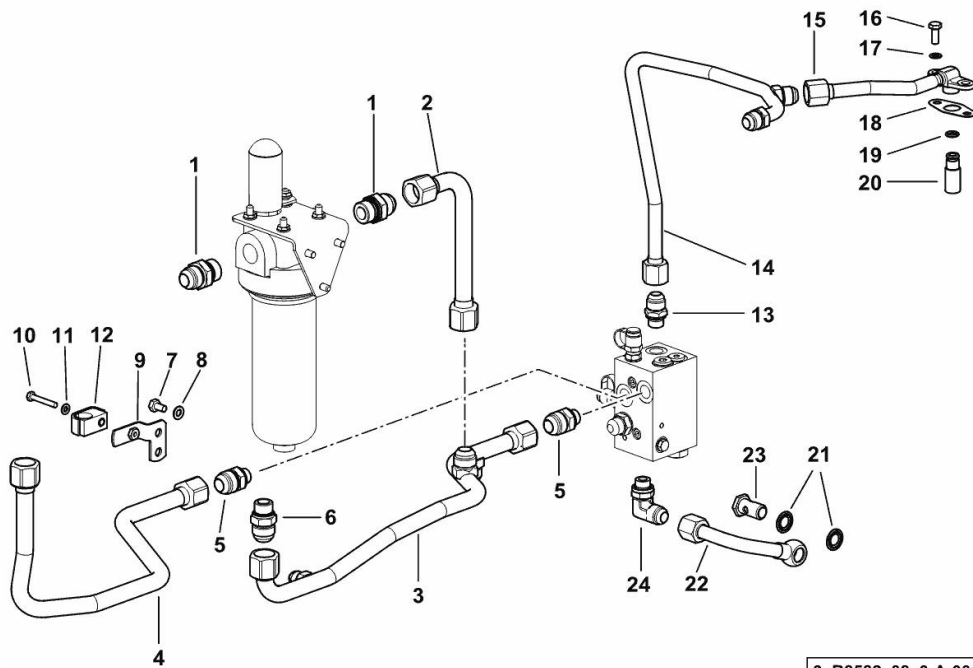

9_R8582_08_0-A-001

Fig.	P/n	QTY	Name
------	-----	-----	------

Notes:

[SILVER³ 100 -> 10001 / 15001]

1	2.3249.100.2	2	pipe fitting M/M 1-16JIC-G3/4
2	0.017.5376.3	1	tube
3	0.017.5400.3	1	tube
4	0.017.5390.3	1	tube
5	2.3249.148.2	2	pipe fitting m 18 - 1/16" JIC
6	2.3249.158.2	1	pipe fitting
7	2.0112.204.2	2	screw m 8 p.1.25x14
8	2.1310.004.2	2	flat washer 8.4x17
9	0.015.2985.3	1	bracket
10	2.0112.015.2	1	screw m 6 p.1x40
11	2.1310.002.2	1	flat washer 6.4x12.5
12	2.3320.111.0	1	terminal Ø 20
13	2.3249.141.2	1	pipe fitting 7/8 JIC-M18
14	0.017.9653.3	1	tube
15	0.017.9661.3	1	tube
16	2.0112.207.2	2	screw m 8 p 1.25 x 20
17	2.1560.004.0	2	copper gasket 8.2 x 14
18	0.052.1558.0/10	1	gasket
19	2.1531.024.0	1	oil seal 10.77x2.62
20	0.008.3750.0	1	tube
21	2.1561.110.0	2	oil seal Ø 18 -B-
22	0.017.5358.3	1	tube
23	2.3335.008.2	1	pipe union m 18 p.1.5 x 32
24	2.3264.018.2	1	pipe fitting m 18 p.1.5

GEARBOX BREATHER SYSTEM

Fig.	P/n	QTY	Name
------	-----	-----	------

Notes:

[SILVER³ 100 -> 10001 / 15001]

1	2.3264.012.2	1	pipe fitting m 18 p.1.5
2	0.017.5722.3	1	tube
4	2.3320.213.0	1	collar Ø 12/16
5	2.1470.002.2	1	lock washer 6
6	2.0112.011.2	1	screw m 6 p.1x30
7	0.015.2326.3	1	tube
8	2.3332.005.2	1	pipe fitting m 16 p.1.5
9	2.1560.012.0	2	gasket 16.2 x 22

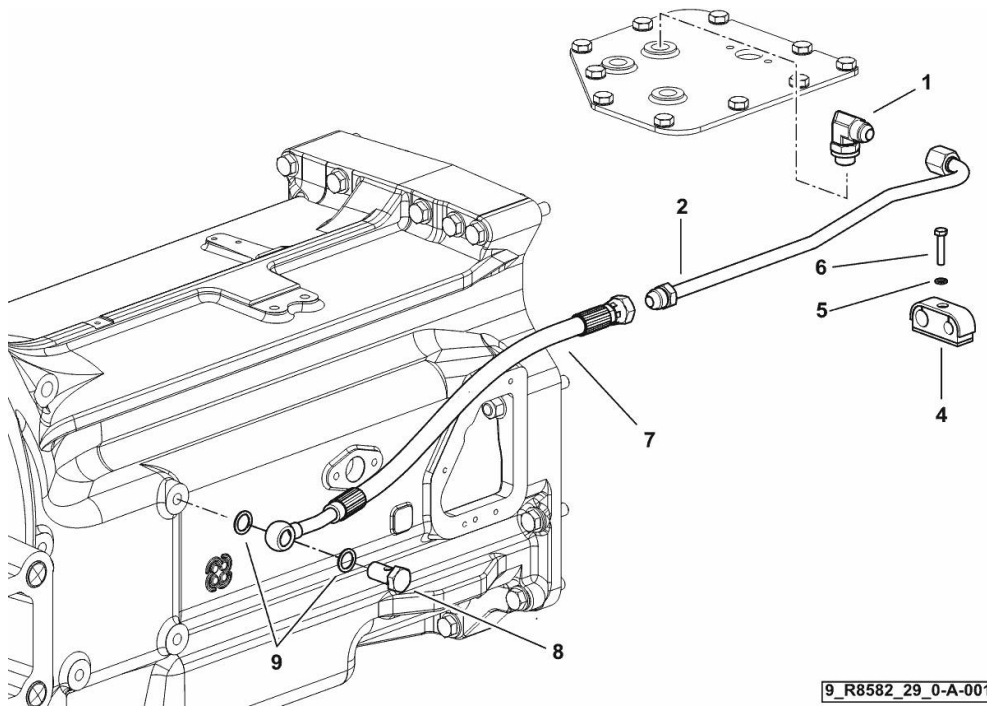

9_R8582_29_0-A-001

REDUCE AND OLD VALVE

Fig.	P/n	QTY	Name
------	-----	-----	------

Notes:

[SILVER³ 100 -> 10001 / 15001]

1	0.015.0001.4/10	1	valve
1.2	0.015.0236.0	1	slider
1.3	2.4019.431.1/30	1	spring 6.9x11.3x2.2x64
1.4	2.1561.108.0	1	oil seal 16
1.5	2.3120.010.4	1	plug m 16 p.1.5
1.6	0.015.0028.0	2	slider
1.7	2.4019.770.1	1	spring
1.8	2.1539.250.0	1	ring 11.3x2.2
1.9	2.3139.021.2	1	plug m 14
1.10	2.1539.251.0	2	ring 15.3x2.2
1.11	2.3199.331.2	1	plug m 18
1.12	2.4019.428.1	1	spring 10.4x7.2x1.6
1.13	2.3199.330.2	1	plug m 18
1.14	2.1560.006.0	1	gasket 10.2 x 16
1.15	2.2810.002.0	1	ball mm 6.350
1.16	2.3199.252.2	1	plug m 10 p.1.5
1.17	2.1531.016.0	1	ring 8.74 x 1.78
2	2.3729.696.0	2	socket
3	2.1480.014.2	2	washer 8
4	2.0312.221.2	2	screw m 8 p.1.25x75

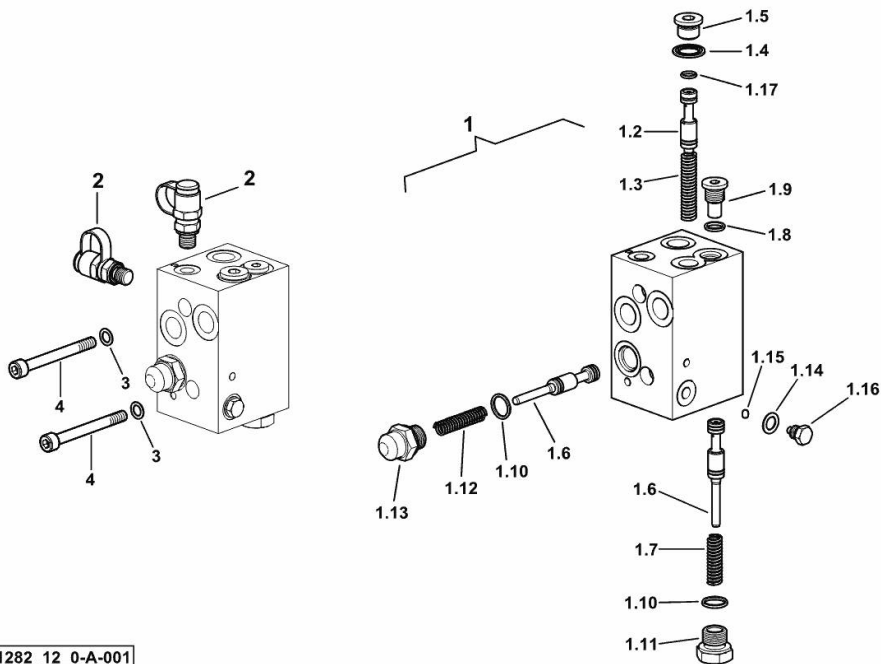

9_H1282_12_0-A-001

PRESSURE CONTROL VALVE

Fig.	P/n	QTY	Name
------	-----	-----	------

Notes:

VERSION WITH 2 HYDRAULIC PUMPS [SILVER³ 100 -> 10001 / 15001] 10019 <-

1	2.3275.015.0	1	pipe fitting m 22								
2	0.018.1328.3	1	tube								
3	2.1560.014.0	2	washer 18.2 x 24								
4	2.3335.008.2	1	pipe union m 18 p.1.5 x 32								
5	0.018.1352.3	1	bracket								
6	2.6839.066.0/10	1	clamp 16								
7	2.1470.002.2	1	lock washer 6								
8	2.1011.103.2	1	nut m 6 p.1								
9	2.3729.420.4	1	valve								
10	04454782	1	plug m 18 p.1.5								
11	2.3272.011.0	2	pipe fitting m 18 p.1.5	12	0.018.1329.3	1	tube	13	2.0112.315.2	2	screw m 10 p.1.5 x 40
12	0.018.1329.3	1	tube	13	2.0112.315.2	2	screw m 10 p.1.5 x 40				
13	2.0112.315.2	2	screw m 10 p.1.5 x 40								

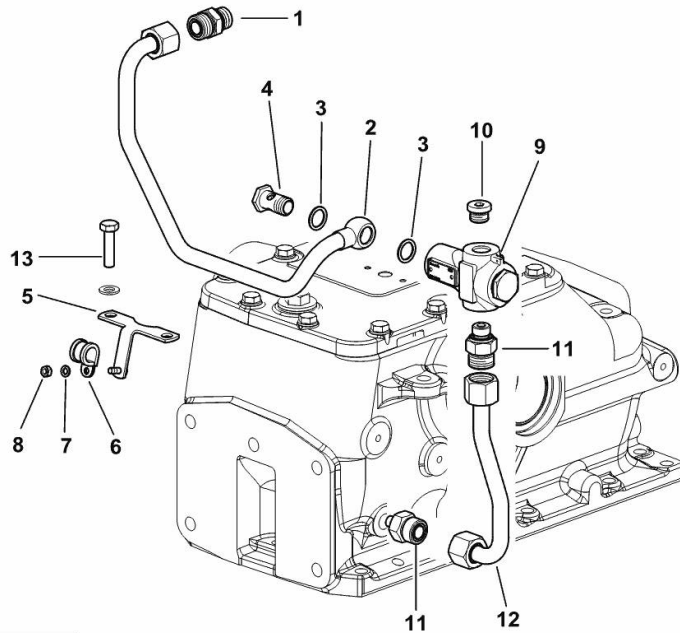

9_R8859_33_0-A-001

HYDRAULIC SYSTEM H-M-L

Fig.	P/n	QTY	Name
------	-----	-----	------

Notes:

[SILVER³ 100 -> 10001 / 15001]

1	0.017.5256.3	1	tube
2	2.1310.004.2	2	flat washer 8.4x17
3	2.0112.207.2	2	screw m 8 p 1.25 x 20
4	2.3249.173.2	1	pipe fitting M/M 7/8 JIC-M22
5	0.017.5255.3	1	tube

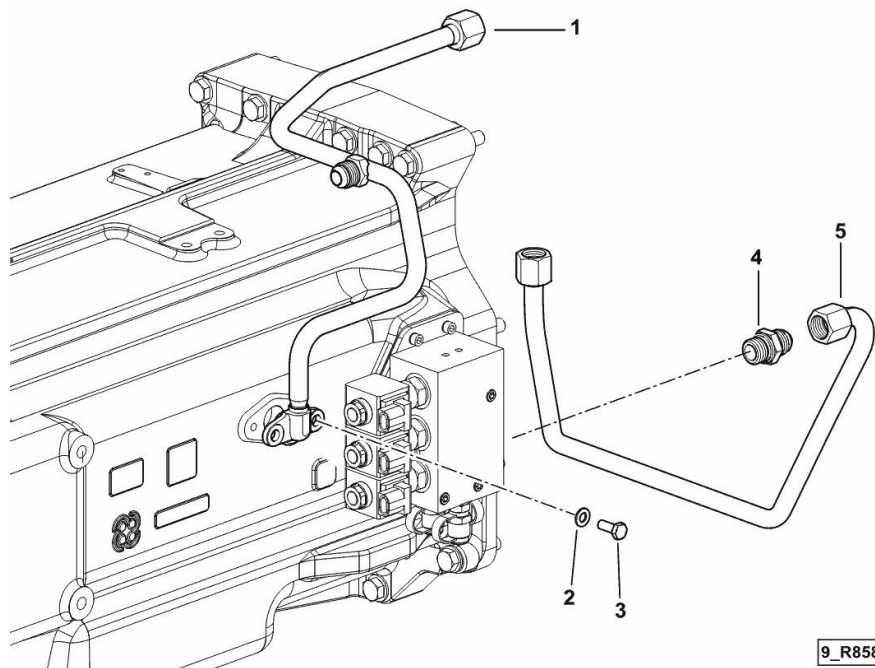

Thank you so much for reading.
Please click the “Buy Now!”
button below to download the
complete manual.



After you pay.

You can download the most
perfect and complete manual in
the world immediately.

Our support email:

ebooklibonline@outlook.com