

ENGINE TYPE-APPROVAL DATA PLATE

Fig.	P/n	QTY	Name
------	-----	-----	------

Notes:

[TIGER 60 2WD ->S10S523WXE1001] [TIGER 60 4WD ->S10S523WTE1001]

1	0.000.0000.1		cannot be supplied MADE BY TREVIGLIO ITALY
2	0.000.0000.1		cannot be supplied MADE AT RANIPET - INDIA

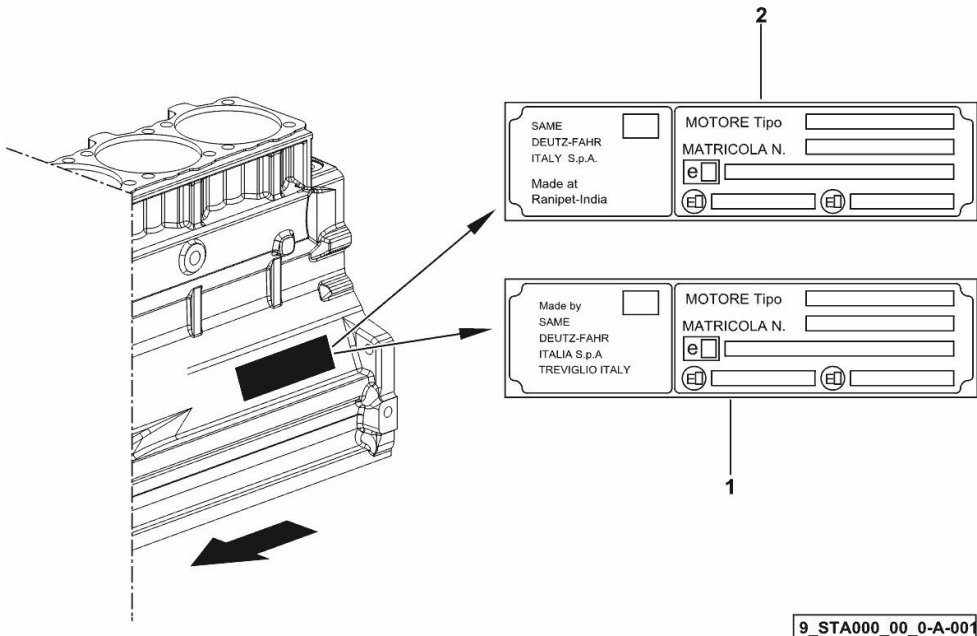

9_STA000_00_0-A-001

CRANKCASE

Fig.	P/n	QTY	Name
------	-----	-----	------

Notes:

FOR ENGINES PRODUCED IN : TREVIGLIO ITALY [TIGER 60 2WD ->S10S523WXE1001] FOR ENGINES

PRODUCED IN : TREVIGLIO ITALY [TIGER 60 4WD ->S10S523WTE1001]

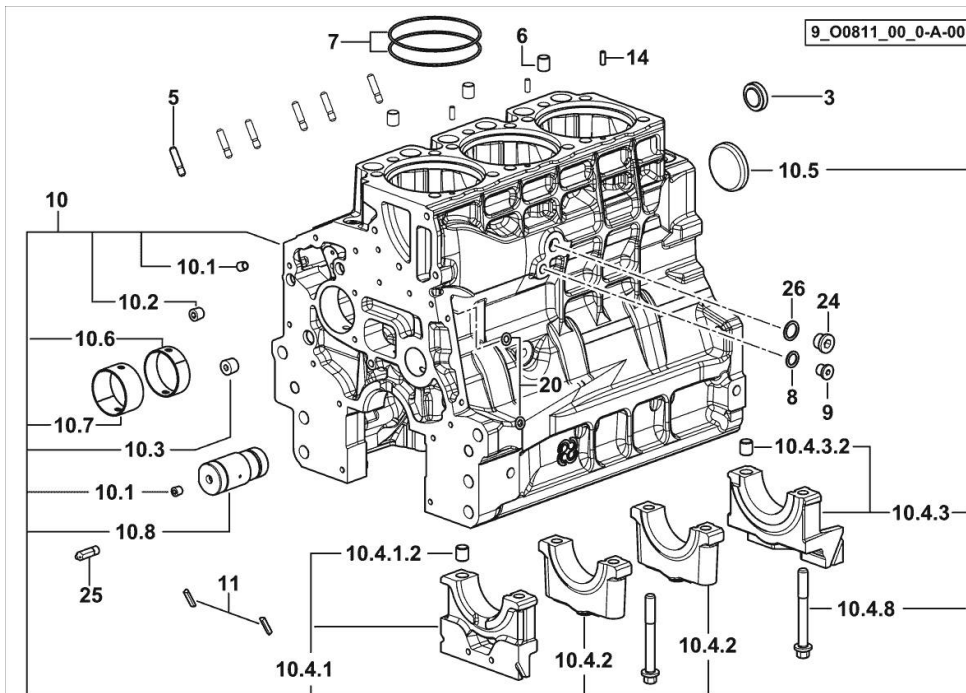

3	2.3199.312.2/20	1	plug m 35x1.5x9.5
5	2.0439.279.7	6	stud bolt m 8 p.1 x 25
6	2.1559.188.2	3	bush 11.4 x 14 x16
7	2.1539.259.0	6	special oil seal 107.62x2.62
8	2.1560.010.0	1	gasket 14.2 x 20
9	2.3199.292.0	1	plug 1/4" gas
10	0.014.9911.4/30	1	crankcase
10.1	2.3130.001.1	12	plug 1/8" gas
10.2	2.3130.002.1	4	plug 1/4" gas
10.3	2.3130.003.1	2	plug 3/8" gas
10.4.1	0.065.1112.3	1	support
10.4.1.2	2.1699.165.0	1	bush 12.3x15x16
10.4.2	0.065.1114.0/10	2	support
10.4.3	0.065.1116.3	1	support
10.4.3.2	2.1699.165.0	1	bush 12.3x15x16
10.4.8	0.065.1117.0	8	screw m 12 x 100
10.5	2.3179.012.0	1	plug 60
10.6	0.065.1140.0	3	special bushing 59X55X20
10.7	0.065.1141.0	1	special bushing 59X55X30
10.8	0.014.1340.0/10	1	pin mm 85
11	0.066.1152.0/10	4	gasket
14	2.1549.154.2	3	bush 4.8x5.8x16
20	2.1470.004.2	4	lock washer 8
24	2.3120.101.0	1	plug m 18 p.1.5
25	0.013.4946.0/10	1	sprayer nozzle
26	2.1560.014.0	1	washer 18.2 x 24

CRANKCASE

Fig.	P/n	QTY	Name
------	-----	-----	------

Notes:

FOR ENGINES PRODUCED IN : TREVIGLIO ITALY [TIGER 60 2WD ->S10S523WXE1001] FOR ENGINES

PRODUCED IN : TREVIGLIO ITALY [TIGER 60 4WD ->S10S523WTE1001]

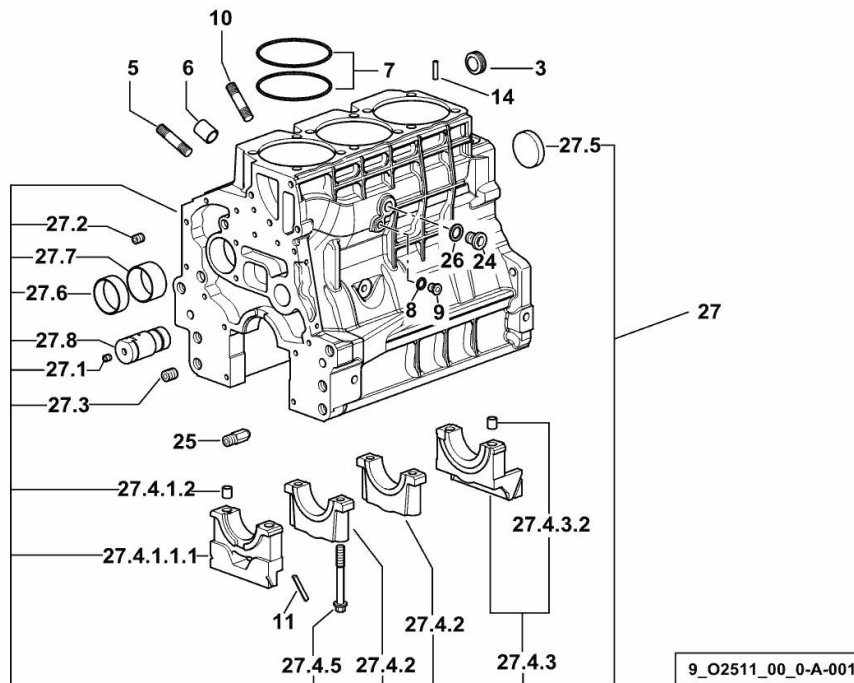

3	2.3199.312.2/20	1	plug m 35x1.5x9.5
5	2.0439.273.7	6	stud bolt m 8
6	2.1559.188.2	3	bush 11.4 x 14 x16
7	2.1539.259.0	6	special oil seal 107.62x2.62
8	2.1560.010.0	1	gasket 14.2 x 20
9	2.3199.292.0	1	plug 1/4" gas
10	2.0432.005.7	1	stud bolt m 8 p.1.5 / p.1 x 25
11	0.066.1152.0/10	4	gasket
14	2.1549.154.2	3	bush 4.8x5.8x16
24	2.3120.101.0	1	plug m 18 p.1.5
25	0.013.4946.0/10	1	sprayer nozzle
26	2.1560.014.0	1	washer 18.2 x 24
27	0.015.2793.4/10	1	crankcase
27.1	2.3130.001.1	9	plug 1/8" gas
27.2	2.3130.002.1	2	plug 1/4" gas
27.3	2.3130.003.1	2	plug 3/8" gas
27.4.1.1.1	0.065.1112.7/10	1	support
27.4.1.2	2.1699.165.0	1	bush 12.3x15x16
27.4.2	0.065.1114.0/10	2	support
27.4.3	0.065.1116.3	1	support
27.4.3.2	2.1699.165.0	1	bush 12.3x15x16
27.4.5	0.065.1117.0	8	screw m 12 x 100
27.5	2.3179.012.0	1	plug 60
27.6	0.065.1140.0	3	special bushing 59X55X20
27.7	0.065.1141.0	1	special bushing 59X55X30
27.8	0.014.1340.0/10	1	pin mm 85

CRANKCASE

Fig.	P/n	QTY	Name
------	-----	-----	------

Notes:

FOR ENGINES PRODUCED IN : RANIPET - INDIA [TIGER 60 2WD ->S10S523WXE1001] FOR ENGINES

PRODUCED IN : RANIPET - INDIA [TIGER 60 4WD ->S10S523WTE1001]

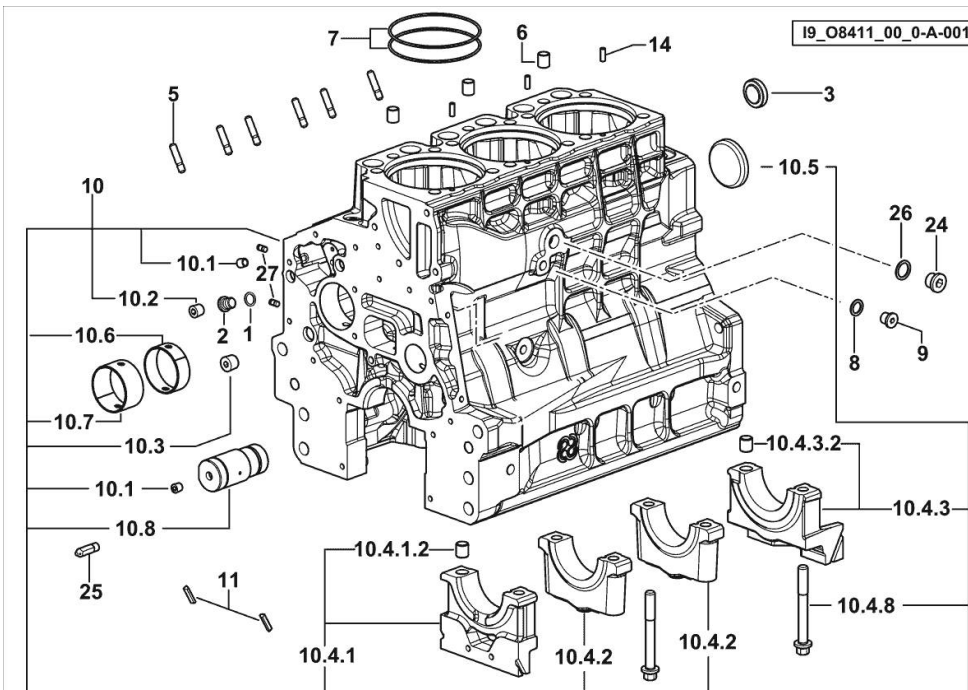

1	2.3120.008.4	1	plug m 12 x 1,5
2	2.1560.008.0	1	gasket 12.2 x 18
3	2.3199.312.2/20	1	plug m 35x1.5x9.5
5	2.0439.279.7	6	stud bolt m 8 p.1 x 25
6	2.1559.188.2	3	bush 11.4 x 14 x16
7	2.1539.259.0	6	special oil seal 107.62x2.62
8	2.1560.010.0	1	gasket 14.2 x 20
9	2.3199.292.0	1	plug 1/4" gas
10	0.014.9911.4/30	1	crankcase
10.1	2.3130.001.1	12	plug 1/8" gas
10.2	2.3130.002.1	4	plug 1/4" gas
10.3	2.3130.003.1	2	plug 3/8" gas
10.4.1	0.065.1112.3	1	support
10.4.1.2	2.1699.165.0	1	bush 12.3x15x16
10.4.2	0.065.1114.0/10	2	support
10.4.3	0.065.1116.3	1	support
10.4.3.2	2.1699.165.0	1	bush 12.3x15x16
10.4.8	0.065.1117.0	8	screw m 12 x 100
10.5	2.3179.012.0	1	plug 60
10.6	0.065.1140.0	3	special bushing 59X55X20
10.7	0.065.1141.0	1	special bushing 59X55X30
10.8	0.014.1340.0/10	1	pin mm 85
11	0.066.1152.0/10	4	gasket
14	2.1549.154.2	3	bush 4.8x5.8x16
24	2.3120.101.0	1	plug m 18 p.1.5
25	0.013.4946.0/10	1	sprayer nozzle
26	2.1560.014.0	1	washer 18.2 x 24
27	2.1890.003.2	2	expansion plug 6

CRANKCASE

Fig.	P/n	QTY	Name
------	-----	-----	------

Notes:

FOR ENGINES PRODUCED IN: RANIPET - INDIA. WITH PF 41 INJECTION PUMP [TIGER 60 2WD ->S10S523WXE1001] FOR ENGINES PRODUCED IN: RANIPET - INDIA. WITH PF 41 INJECTION PUMP [TIGER 60 4WD ->S10S523WTE1001]

19_K2511_00_0-B-001

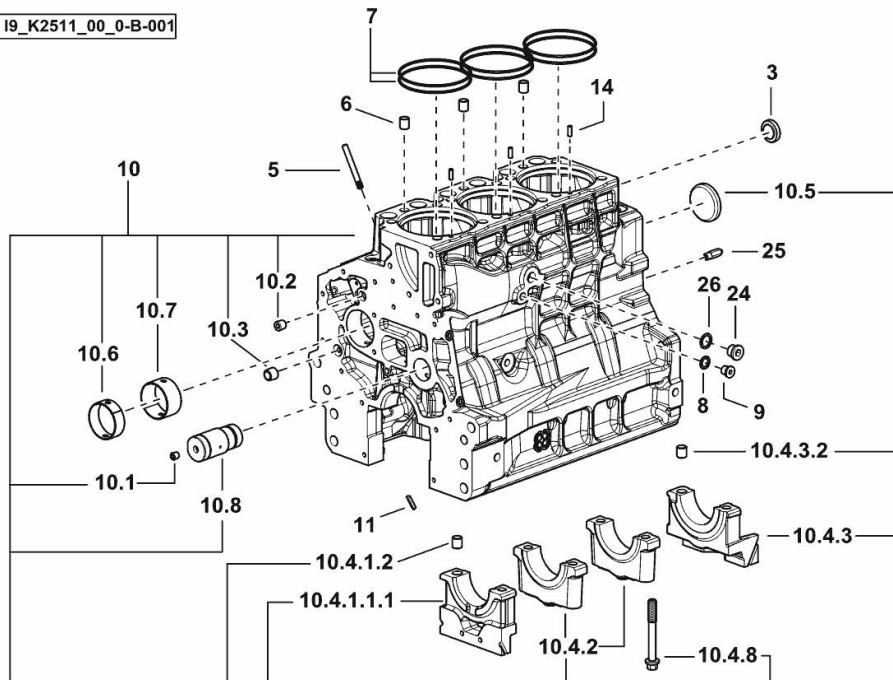

3	2.3199.312.2/20	1	plug m 35x1.5x9.5
5	2.0439.273.7	6	stud bolt m 8
6	2.1559.188.2	3	bush 11.4 x 14 x16
7	2.1539.259.0	6	special oil seal 107.62x2.62
8	2.1560.010.0	1	gasket 14.2 x 20
9	2.3199.292.0	1	plug 1/4" gas
10	0.018.3196.4	1	crankcase
10.1	2.3130.001.1	9	plug 1/8" gas
10.2	2.3130.002.1	2	plug 1/4" gas
10.3	2.3130.003.1	2	plug 3/8" gas
10.4.1.1.1	0.065.1112.7/10	1	support
10.4.1.2	2.1699.165.0	1	bush 12.3x15x16
10.4.2	0.065.1114.0/10	2	support
10.4.3	0.065.1116.3	1	support
10.4.3.2	2.1699.165.0	1	bush 12.3x15x16
10.4.8	0.065.1117.0	8	screw m 12 x 100
10.5	2.3179.012.0	1	plug 60
10.6	0.065.1140.0	3	special bushing 59X55X20
10.7	0.065.1141.0	1	special bushing 59X55X30
10.8	0.014.1340.0/10	1	pin mm 85
11	0.066.1152.0/10	4	gasket
14	2.1549.154.2	3	bush 4.8x5.8x16
24	2.3120.101.0	1	plug m 18 p.1.5
25	0.013.4946.0/10	1	sprayer nozzle
26	2.1560.014.0	1	washer 18.2 x 24

MONOBLOC ENGINE-GEARBOX CONNECTING FLANGE

Fig.	P/n	QTY	Name
------	-----	-----	------

Notes:

[TIGER 60 2WD ->S10S523WXE1001] [TIGER 60 4WD ->S10S523WTE1001]

1	0.015.8814.0	1	flange
2	2.0112.511.2	8	screw m 14 p.2 x 30
3	2.0432.255.7	2	stud bolt m 12 p.1.75-1.25x25
4	2.1651.912.0	4	cylindrical plug 12x28
5	2.0512.404.7	2	screw

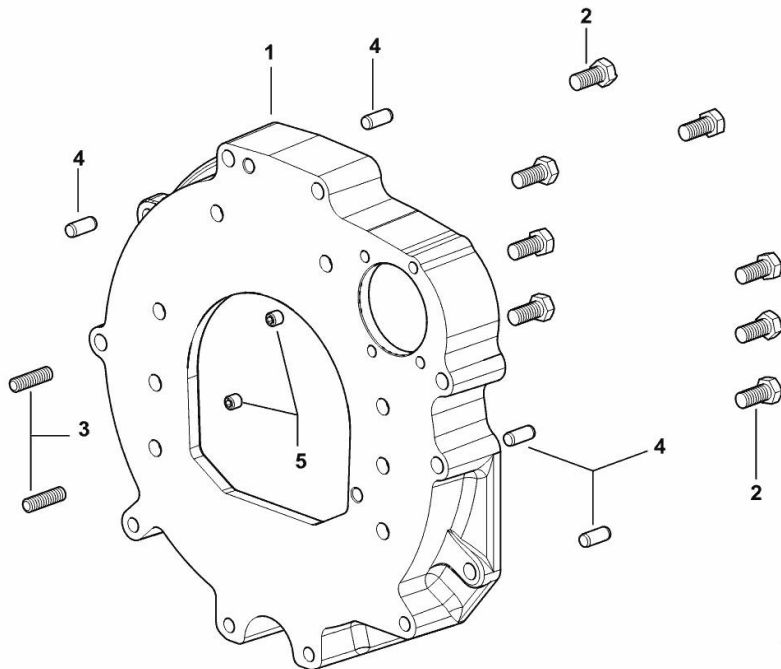

I9_38511_01_0-A-001

FITTING FOR ENGINE OIL PRESSURE SWITCH

Fig.	P/n	QTY	Name
------	-----	-----	------

Notes:

FOR ENGINES PRODUCED IN : TREVIGLIO ITALY [TIGER 60 2WD ->S10S523WXE1001] FOR ENGINES PRODUCED IN : TREVIGLIO ITALY [TIGER 60 4WD ->S10S523WTE1001]

30	2.1560.008.0	2	gasket 12.2 x 18
31	2.3339.448.2	1	pipe union m 12 p.1.75
32	2.3249.014.2	1	pipe fitting m 12 p.1.5

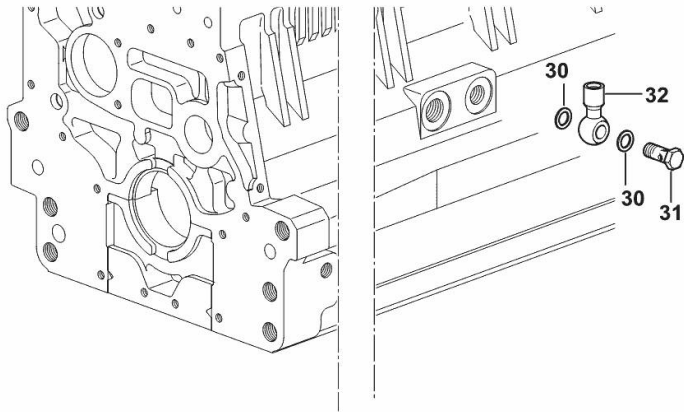

9_34815_07_0-A-001

FITTING FOR ENGINE OIL PRESSURE SWITCH

Fig.	P/n	QTY	Name
------	-----	-----	------

Notes:

FOR ENGINES PRODUCED IN: RANIPET - INDIA. WITH PF 41 INJECTION PUMP [TIGER 60 2WD ->S10S523WXE1001] FOR ENGINES PRODUCED IN: RANIPET - INDIA. WITH PF 41 INJECTION PUMP [TIGER 60 4WD ->S10S523WTE1001] FOR ENGINES PRODUCED IN: RANIPET - INDIA. WITH PF 47 INJECTION PUMP [TIGER 60 2WD ->S10S523WXE1001] FOR ENGINES PRODUCED IN: RANIPET - INDIA. WITH PF 47 INJECTION PUMP [TIGER 60 4WD ->S10S523WTE1001]

30	2.1560.008.0	2	gasket 12.2 x 18
31	2.3339.448.2	1	pipe union m 12 p.1.75
32	2.3249.014.2	1	pipe fitting m 12 p.1.5

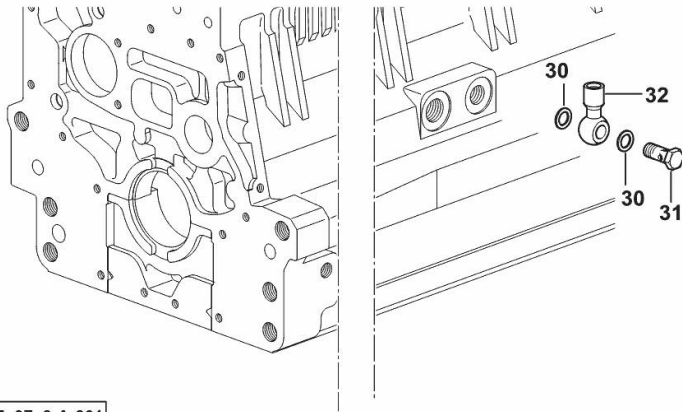

19_36215_07_0-A-001

CRANKSHAFT

Fig.	P/n	QTY	Name
------	-----	-----	------

Notes:

FOR ENGINES PRODUCED IN : TREVIGLIO ITALY [TIGER 60 2WD ->S10S523WXE1001] 1413 <- FOR ENGINES PRODUCED IN : TREVIGLIO ITALY [TIGER 60 4WD ->S10S523WTE1001] 1413 <-

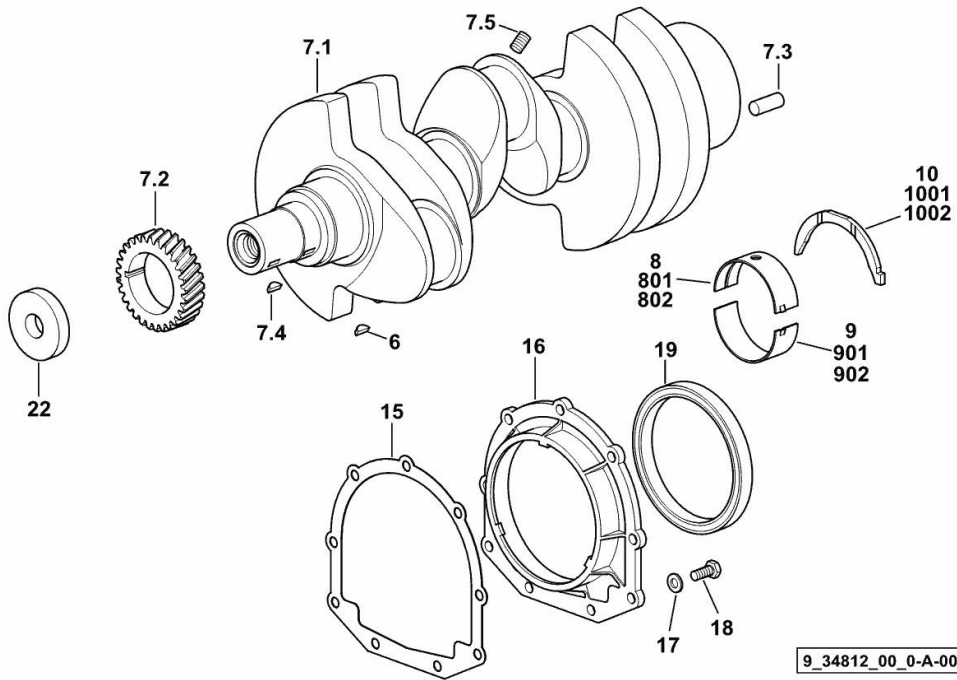

6	2.1720.006.0	1	key 4x6.5
7.1	0.007.1554.0/20	1	crankshaft
7.2	0.065.1323.0/30	1	gear Z = 29
7.3	2.1651.915.0	1	pin 12x35
7.4	2.1720.006.0	1	key 4x6.5
7.5	2.3130.001.1	3	plug 1/8" gas
8	0.065.1215.0/10	4	main half bushing STANDARD
9	0.065.1216.0/10	4	main half bushing STANDARD
10	0.065.1218.0	4	shim STANDARD
15	0.065.1254.0/20	1	gasket
16	0.007.1711.0/10	1	cover
17	2.1475.002.2	9	conical washer 8
18	2.0112.207.2	9	screw m 8 p 1.25 x 20
19	2.1529.073.0	1	special oil seal 110x130x13
22	2.1599.524.7	1	washer 21x60x12
801	0.065.1215.7		main half bushing - mm 0.25
802	0.065.1215.8		main half bushing - mm 0.50
901	0.065.1216.7		main half bushing - mm 0.25
902	0.065.1216.8		main half bushing - mm 0.50
1001	0.065.1218.7		shim + mm 0.10
1002	0.065.1218.8		shim + mm 0.15

9_34812_00_0-A-001

CRANKSHAFT

Fig.	P/n	QTY	Name
------	-----	-----	------

Notes:

FOR ENGINES PRODUCED IN : TREVIGLIO ITALY [TIGER 60 2WD ->S10S523WXE1001] FOR ENGINES PRODUCED IN : TREVIGLIO ITALY [TIGER 60 4WD ->S10S523WTE1001]

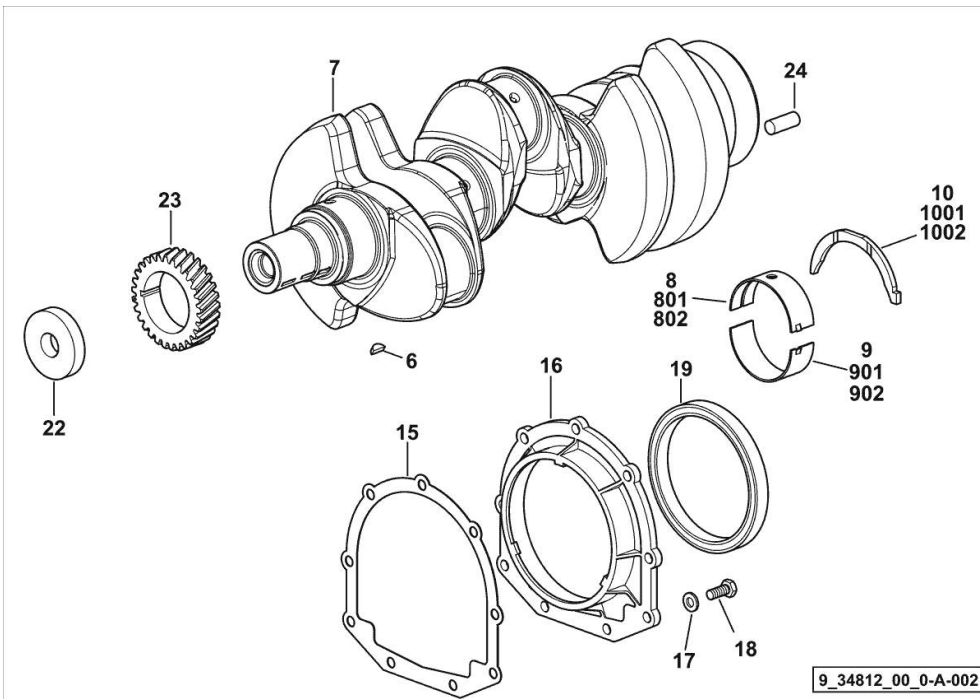

9_34812_00_0-A-002

6	2.1720.006.0	1	key 4x6.5
7	0.019.2255.0/20	1	crankshaft
8	0.019.5455.0	4	main half bushing STANDARD
9	0.019.5456.0	4	main half bushing STANDARD
10	0.065.1218.0	4	shim STANDARD
15	0.065.1254.0/20	1	gasket
16	0.007.1711.0/10	1	cover
17	2.1475.002.2	9	conical washer 8
18	2.0112.207.2	9	screw m 8 p 1.25 x 20
19	2.1529.073.0	1	special oil seal 110x130x13
22	2.1599.524.7	1	washer 21x60x12
23	0.065.1323.0/30	1	gear Z = 29
24	2.1651.915.0	1	pin 12x35
801	0.065.1215.7	-	main half bushing - mm 0.25
802	0.065.1215.8	-	main half bushing - mm 0.50
901	0.065.1216.7	-	main half bushing - mm 0.25
902	0.065.1216.8	-	main half bushing - mm 0.50
1001	0.065.1218.7	-	shim + mm 0.10
1002	0.065.1218.8	-	shim + mm 0.15

Thank you so much for reading.
Please click the “Buy Now!”
button below to download the
complete manual.



After you pay.

You can download the most
perfect and complete manual in
the world immediately.

Our support email:

ebooklibonline@outlook.com