

Page Title	Page Number
CYLINDER BLOCK - AD3.152	2
CRANKSHAFT & FLYWHEEL - AD3.152	6
CYLINDER HEAD AND COVER - AD3.152	8
ROCKER ARM - AD3.152	10
TIMING GEAR - AD3.152	12
LUBRICATING OIL SYSTEM - AD3.152	16
WATER PUMP - AD3.152	20
FUEL PIPINGS - AD3.152	22
FUEL FILTER - AD3.152	26
FUEL LIFT PUMP - AD3.152	28
STARTER MOTOR - LUCAS- FROM SERIAL 02-1981	30
ALTERNATOR	32
GASKET SET - AD3.152	34
ENGINE - AD3.152	36
FUEL TANK	38
FUEL TANK AND PIPINGS	40
RADIATOR	42
INDUCTION MANIFOLD AND AIR FILTER	44
EXHAUST MANIFOLD - MUFFLER VERTICAL	46
EXHAUST MANIFOLD AND MUFFLER - MUFFLER HORIZONTAL	48
ENGINE CONTROLS	50
ELECTRICAL WIRING	52
BATTERY	54
LIGHTS	56
INSTRUMENT PANEL	58
DUAL CLUTCH - LUK TYPE	60
DUAL CLUTCH - O.M.G.	62
CLUTCH CONTROL	64
CENTRE AXLE HOUSING AND TRANSMISSION HOUSING	68
SYNCHRO-MESH TRANSMISSION	70
REDUCER	74
TRANSMISSION CONTROLS	76
REDUCER CONTROL	78
POWER TAKE OFF - STANDARD	80
POWER TAKE OFF - 540/1000 R.P.M.	82
DIFFERENTIAL	84
DIFFERENTIAL LOCK	86
REAR AXLE-HOUSING	88
BRAKE AND CONTROLS	90
HAND BRAKE	94
BRAKE PUMP	96
BRAKE CYLINDER	98
RIM AND TIRES	100
FRONT AXLE - 2 WHEEL DRIVE	102
STEERING HYDRAULIC EQUIPMENT	104
STEERING CONTROL VALVE - 2 WHEEL DRIVE	108
STEERING CONTROL VALVE - 4 WHEEL DRIVE	110
STEERING OIL PUMP	112
STEERING CYLINDER - 2 WHEEL DRIVE	114
STEERING CYLINDER - 4 WHEEL DRIVE	116
HYDRAULIC LIFT PUMP AND LINES	118
OIL PUMP - HYDRAULIC LIFT	120
HYDRAULIC CONTROL VALVE - HYDRAULIC LIFT	122
HYDRAULIC LIFT	124
LIFT CONTROL	128
PIPINGS AUXILIARY CONTROL VALVES	132
AUXILIARY HYDRAULICS VALVE - STANDARD	134
AUXILIARY HYDRAULICS VALVE - FLOATING	136
VALVES - HYDRAULICS EQUIPMENT	138
PIPINGS CONTROLS VALVE - TILL TYPE	140
AUXILIARY HYDRAULIC VALVES - TILL TYPE	141A
LINKAGE - CAT 1 AND 2	142
REAR HOOK	148
REAR HOOK	150
DRAWBAR	152
HOOD BRACKET AND INSTRUMENT PANEL	154

TABLE OF CONTENT

00

ENGINE HOOD	156
HARDNOSE AND GRILLES	158
MOUNTING FRAME AND FRONT WEIGHTS	160
FENDERS	162
FENDERS AND PLATFORM	164
SEAT - GRAMMER	168
SEAT - BOSTROM	170
SAFETY FRAME	172
DECAL AND EMBLEMS	176
DECAL AND EMBLEMS	180
TRANSFER GEAR BOX - 4 WHEEL DRIVE	183A
FRONT AXLE - DIFFERENTIAL	183E
FRONT AXLE - FINAL DRIVE	183I
TOOL GROUP	184

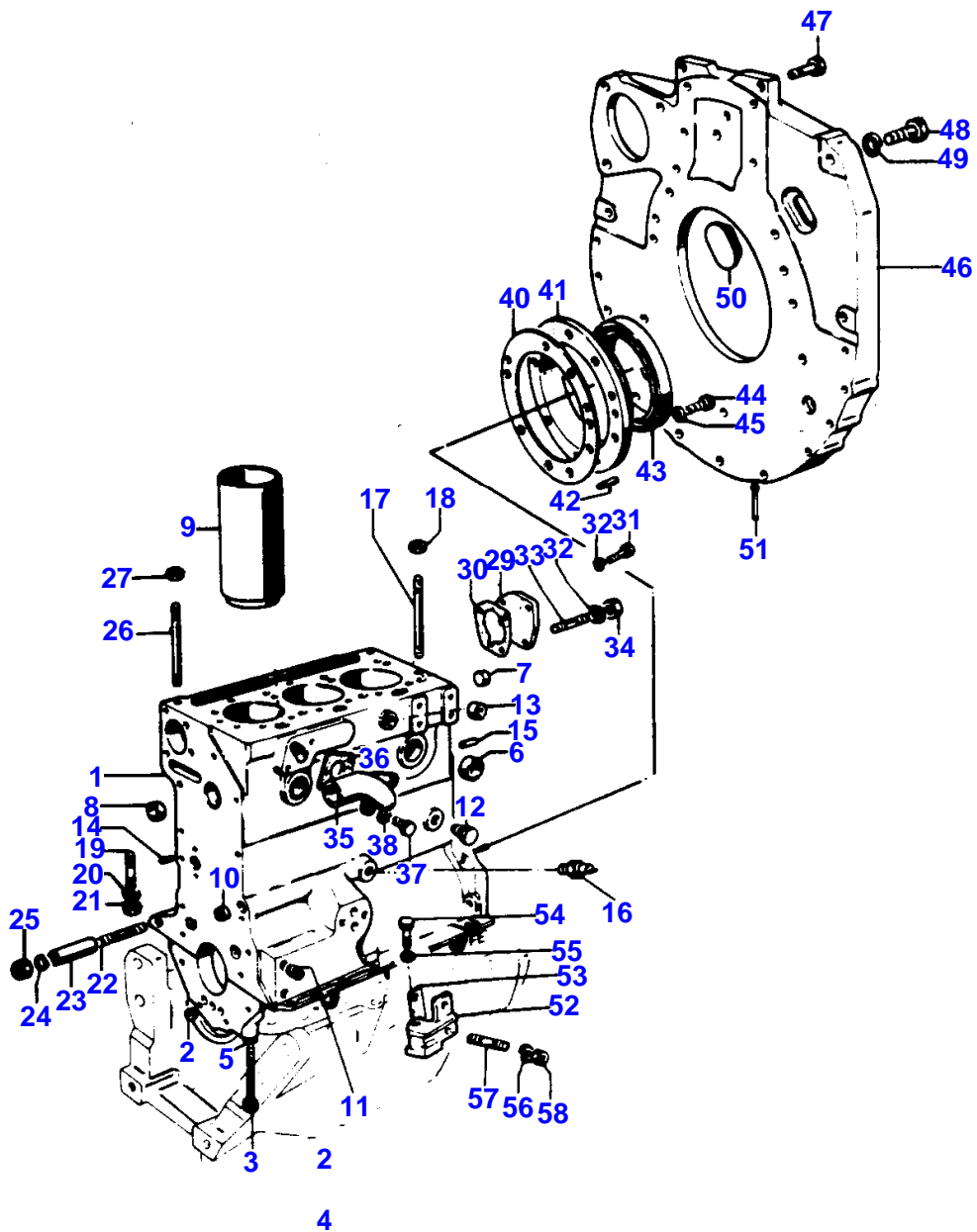

Item	Part Number	Qty	Description	Comments
				AD3.152
1	64573	1	Cylinder Block	
2	0870001	8	Thimble	1
3	32181442	6	Screw	1
4	32181448	2	Screw	1
5	2415608	2	O Ring	1
6	0650563	4	Plug	1
7	0650664	1	Plug	1
8	0650710	1	Plug	1
9	31358345	3	Liner	1
	31358381	3	Liner	(A)
10	0650566	2	Plug	
11	32114471	3	Plug	
12	32161114	1	Plug	
13	32114451	2	Plug	
14	0350005	1	Dowel	
15	0350016	2	Dowel	
16	1423895M91	1	Switch	
17	32524132	2	Stud	
18	33221329	2	Nut	
19	0826285	1	Stud	
20	0920053	1	Washer	
21	0576002	1	Nut	
22	363036X1	1	Screw	
23	33266125	1	Spacer	
24	33121417	X	Shim	Thickness 0,9 MM
	33121416	X	Shim	Thickness 0,25 MM
	0760050	X	Shim	Thickness 0,13 MM
	33121415	X	Shim	Thickness 0,05 MM
25	353427X1	1	Nut Unf	
26	32524148	3	Stud	
27	33221315	3	Nut	
29	37416753	1	Plate	
30	36862511	1	Joint	
31	0746253	2	Screw	
32	0920053	3	Washer	
33	0826201	1	Stud	
34	0576002	1	Nut	
35	0201045	1	Connection	
36	0490486	1	Joint	
37	0746255	2	Setscrew	
38	0920106	2	Washer	
40	33826111	1	Joint	
41	37424611	1	Housing	
42	0350015	2	Dowel	
43	2418F475	1	Seal	
44	0746255	9	Setscrew	
45	0920003	9	Washer	
46	37147974	1	Plate	
47	0720798	2	Screw	
48	0746454	6	Setscrew	
49	0920054	6	Washer	
50	37813113	1	Plug	
51	0610045	1	Pin	
52	38156311	1	Bracket	
53	36113131	1	Spacer	
54	0097109	1	Bolt	
55	0920058	1	Washer	
56	0920056	2	Washer	
57	0826833	2	Stud	
58	0576005	2	Nut	

(A)
PRESS FIT

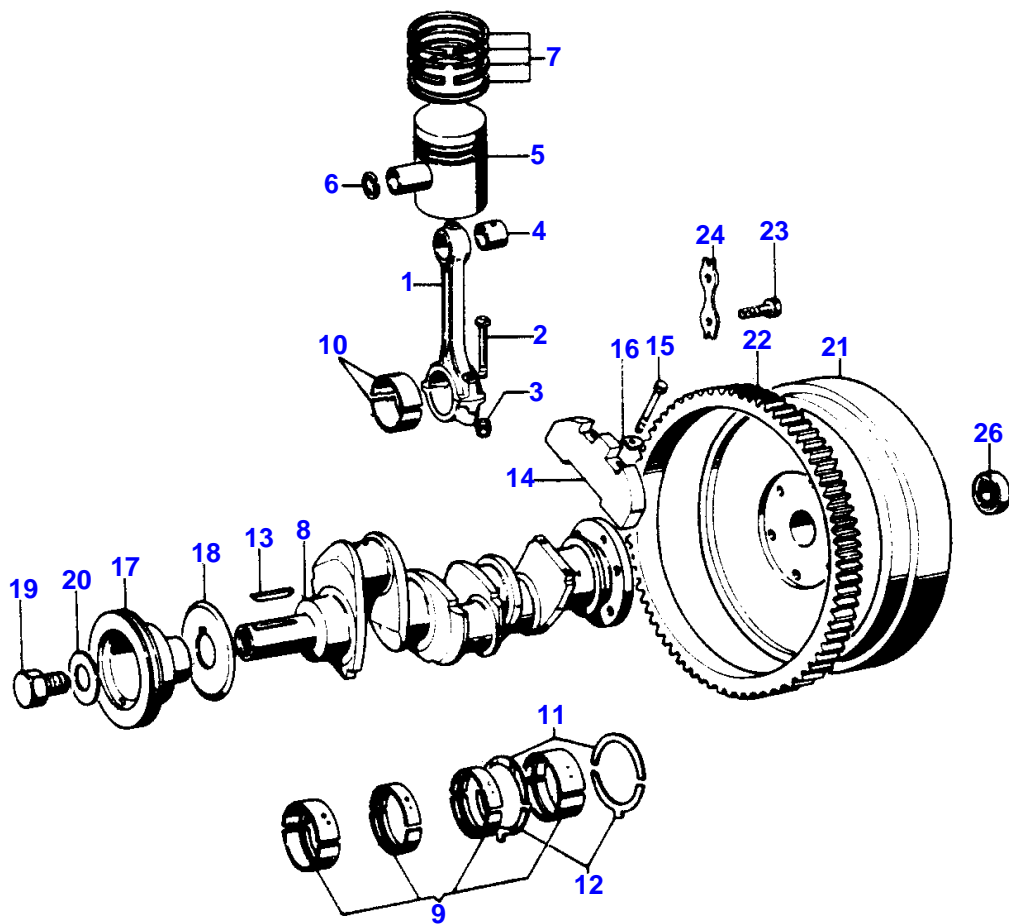

CRANKSHAFT & FLYWHEEL - AD3.152

Item	Part Number	Qty	Description	Comments
				AD3.152
1	M7BJ0014	3	Kit, Conrod	
2	0095250	6	Bolt	1
3	33221327	6	Nut	1
4	31134151	3	Bush	1
5	89214	3	Kit, Piston	
6	0170001	6	Circlip	5
7	41158065	3	Kit, Piston Ring	
8	94458	1	Kit, Crankshaft	
9	68084	X	Kit, Bearing	8
	68084A	X	Kit, Bearing	(A) Thickness -0,254 MM
9	68084B	X	Kit, Bearing	(A) Thickness -0,508 MM
9	68084C	X	Kit, Bearing	(A) Thickness -0,762 MM
10	85036	X	Kit, Bearing	8
	85036A	X	Kit, Bearing	(A) Thickness -0,254 MM
10	85036B	X	Kit, Bearing	(A) Thickness -0,508 MM
10	85036C	X	Kit, Bearing	(A) Thickness -0,762 MM
11	31137211	2	Thrust Washer	8
	31137212	X	Washer	Thickness +0,178 MM
12	31137221	2	Thrust Washer	
	31137222	X	Washer	Thickness +0,178 MM
13	36271704	1	Woodruff Key	
14	31328241	2	Weight	
15	2185189	4	Screw	
16	31731516	2	Washer	Left Hand
	31731515	2	Washer	Right Hand
17	31147788	1	Pulley,Crank	
18	33176137	1	Washer	
19	32162312	1	Screw	
20	33125112	1	Washer	
21	1825512M1	1	Flywheel	
22	0410236	1	Starter Ring	
23	973013M1	6	Bolt	
24	0921062	3	Tab Washer	
26	339599X1	1	Bearing Ball	(A) BEARING ARE SEMIFINISHED

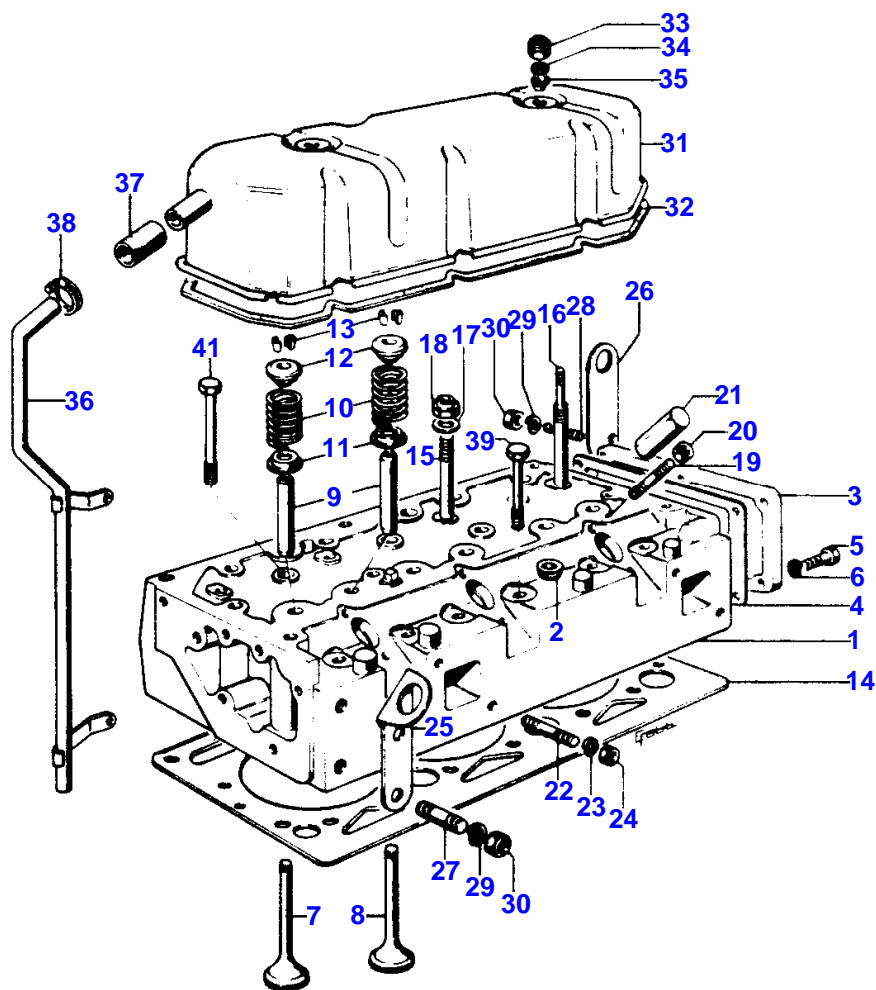

CYLINDER HEAD AND COVER - AD3.152

Item	Part Number	Qty	Description	Comments
				AD3.152
1	A5BD2722	1	Cylinder Head	
2	2431154	2	Plug	1
3	0940737	1	Plate	1
4	0490485	1	Joint	1
5	0746254	6	Setscrew	1
6	0920053	6	Washer	1
7	31431681	3	Valve Inlet	1
8	31431011	3	Valve Exhaust	1
9	33261723	6	Guide	1
10	0780006	6	Spring	1
11	33415133	6	Washer	1
12	0150008	6	Cap	1
13	0230001	12	Cotter	(A) 1
14	36812127	1	Gasket	
15	0826469	2	Stud	
16	32754412	2	Stud	
17	0920004	4	Washer	
18	2211283	4	Nut	
19	0826264	6	Stud	
20	0576002	3	Nut	
21	32726512	3	Nut	
22		4	Stud	See Page - Reference Number 44
23		4	Washer	See Page - Reference Number 44
24		4	Nut	See Page - Reference Number 44
25	36456321	1	Plate	
26	36531408	1	Plate	
27	0826462	2	Stud	
28	0826466	2	Stud	
29	0920054	4	Washer	
30	2188135	4	Nut	
31	37188557	1	Cyl.Head Cover	
32	36811115	1	Joint	
33	0576102	2	Nut	
34	0920003	2	Washer	Up to Serial or Engine Number U787014N
	3314P004	2	Washer	From Serial or Engine Number U787015N
35	0920302	2	Washer	
36	35732479	1	Pipe,Breather	
37	0202058	1	Hose	
38	2481863	2	Clip	
39	32181457	4	Screw	
41	32181458	9	Screw	

(A)
SERVICED IN PAIR

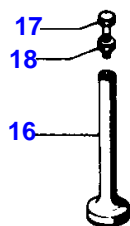
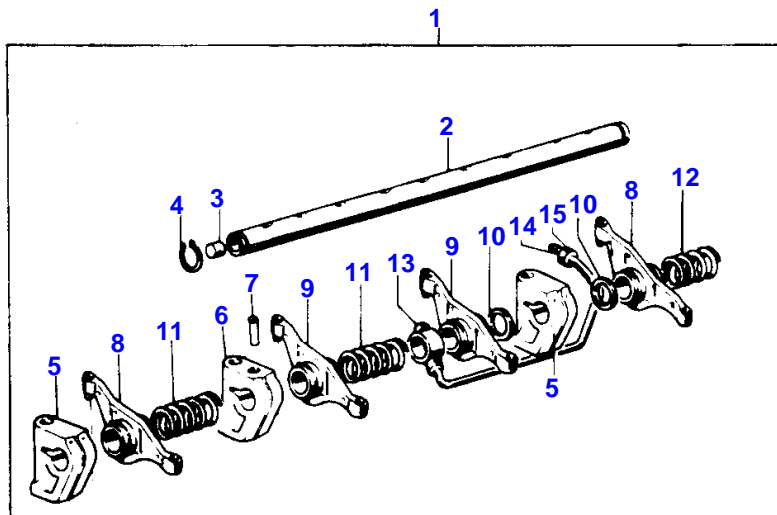

Item	Part Number	Qty	Description	Comments
				AD3.152
1	41151306	1	Rocker Shaft Ass	
2	U7LR0002	1	Rocker Shaft	1
3	0650507	2	Plug	2
4	0170033	2	Circlip	1
5	0101138	3	Bracket	1
6	37521212	1	Bracket	1
7	2112A066	1	Pin	1
8	3737A031	3	Lever	1
9	3737A041	3	Lever	1
10	0330505	4	Spacer	1
11	0780005	2	Spring	1
12	0780175	1	Spring	1
13	35568352	1	Pipe,Oil	1
14	0566002	1	Olive	13
15	0576111	1	Nut	13
16	0860012	6	Tappet	
17	0720677	6	Screw	
18	0576052	6	Nut	

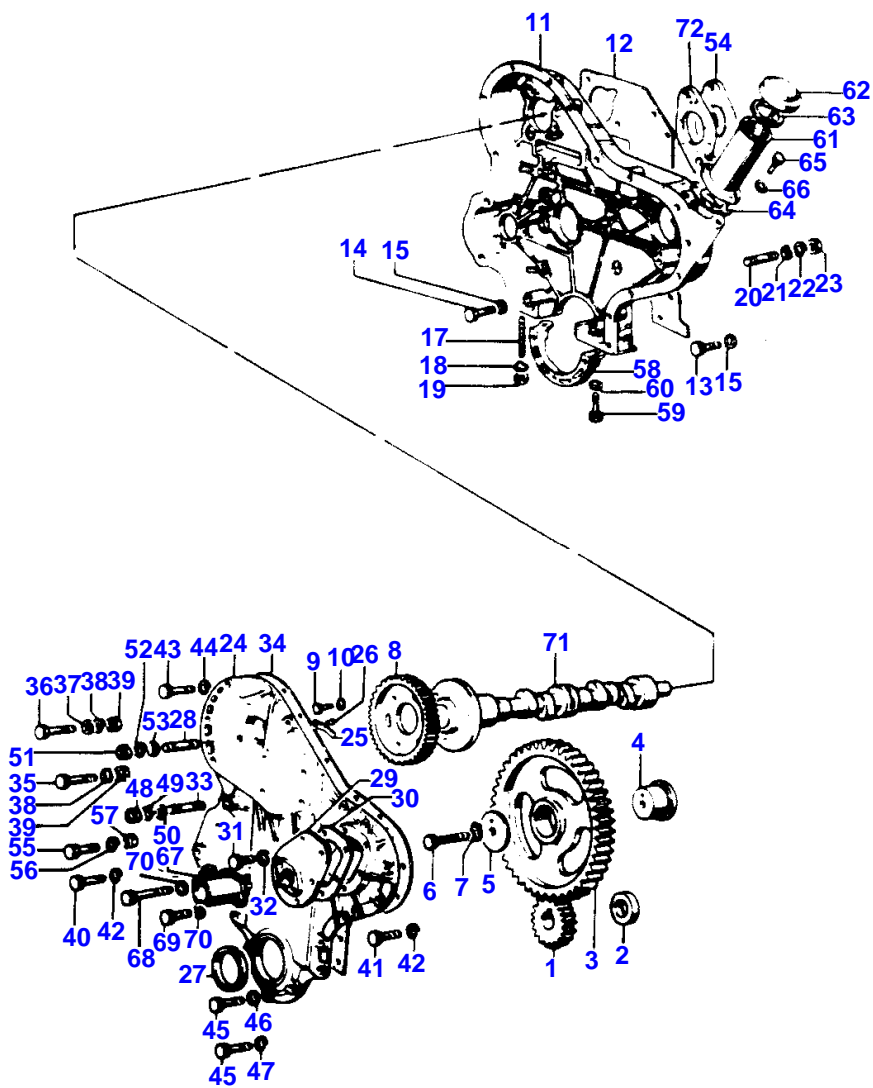

TIMING GEAR - AD3.152

Item	Part Number	Qty	Description	Comments
				AD3.152
1	0410132	1	Gear,Crankshaft	Number of teeth/spines 25
2	0330811	1	Spacer	
3	31164362	1	Gear,Idler	Number of teeth/spines 90
4	0995447	1	Hub	
5	0940738	1	Plate	
6	0095199	1	Screw	
7	0920883	1	Washer	
8	0410241	1	Gear,Camshaft	Number of teeth/spines 50
9	0746214	3	Screw	
10	0920053	3	Washer	
11	37161481	1	Timing Case	
12	36814119	1	Joint	
13	0746355	12	Screw	
14	0096234	2	Bolt	
15	0920053	14	Washer	
17	0826265	2	Stud	
18	0920053	2	Washer	
19	0576002	2	Nut	
20	0827619	3	Stud	
21	0920003	3	Washer	
22	0920053	3	Washer	
23	0576002	3	Nut	
24	A5FH0197	1	Cover	
25	3661P002	1	Spring	24
26	2126151	1	Rivet	24
27	2415344	1	Seal	24
28	0827622	1	Stud	24
29	37523171	1	Cover	24
30	36862512	1	Joint	24
31	0748353	6	Screw	24
32	2411151	6	Washer	24
33	0827622	1	Stud	24
34	36813136	1	Joint	
35	0096213	2	Bolt	
36	0096242	1	Bolt	
37	0920003	1	Washer	
38	0920053	3	Washer	
39	0576002	3	Nut	
40	0748354	1	Screw	
41	0748353	8	Screw	
42	0920052	9	Washer	
43	0748414	2	Setscrew	
44	0920053	2	Washer	
45	0748405	3	Screw	
46	2411152	1	Washer	
47	0920053	2	Washer	
48	0576002	1	Nut	
49	0920053	1	Washer	
50	0920497	1	Washer	
51	0576002	1	Nut	
52	0920053	1	Washer	
53	0920460	1	Spacer	
54	37461104	1	Plate	
55	0748510	2	Bolt	
56	0920054	2	Washer	
57	2238153	2	Nut	
58	37354312	1	Timinggear Cover	
59	0096232	2	Bolt	
60	0920053	2	Washer	
61	35784123	1	Filler	
62	2487854	1	Cap	61
63	24870001	1	Joint	62
64	36837413	1	Joint	
65	0746254	2	Setscrew	
66	2411152	2	Washer	
67	2758346	1	Angle Drive	
68	0748353	1	Screw	
69	0748357	1	Screw	
70	2411151	2	Washer	

MASSEY FERGUSON

MF 154 V TRACTOR - 3310904

3310904

TIMING GEAR - AD3.152

12

Item	Part Number	Qty	Description	Comments
71	31415261	1	Camshaft	
72	36835413	1	Joint	

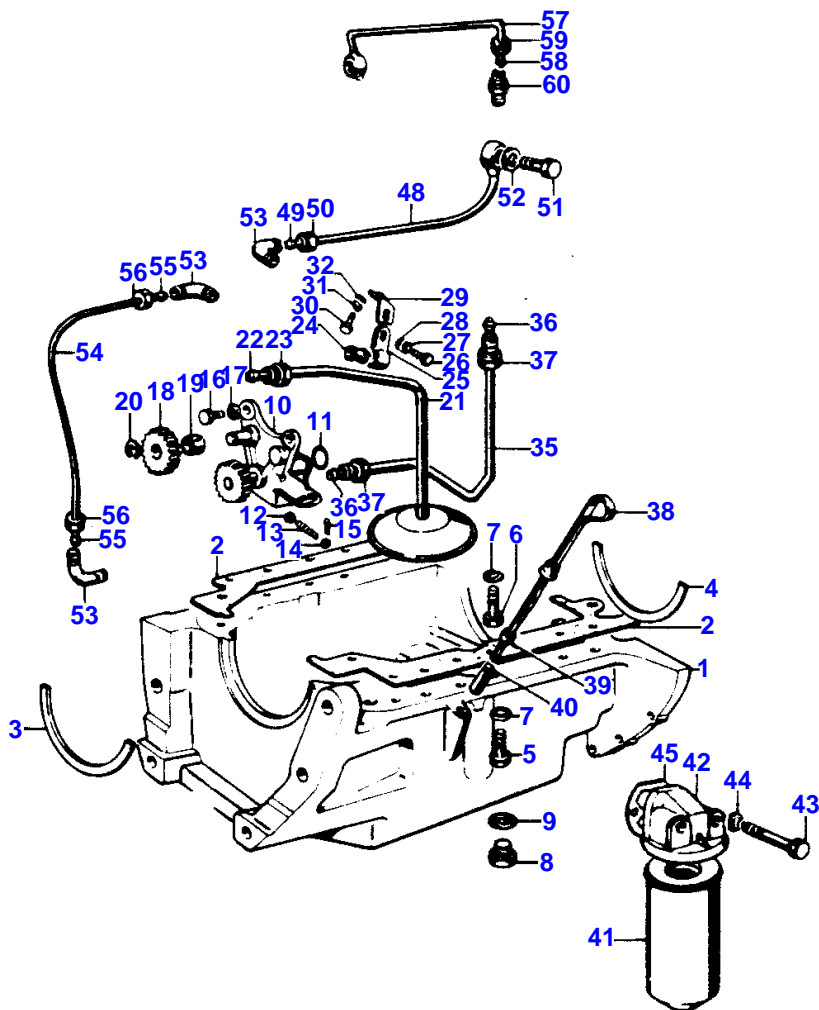

Buy Now



Our support email:

ebooklibonline@outlook.com