

Page Title	Page Number
ENGINE ASSEMBLY-T3.152.4 ENGINE	1
SHORT ENGINE-TABLE PK ACEC9107	2
CYLINDER BLOCK-T3.152.4 ENGINE	3
CRANKSHAFT, PISTONS AND CONNECTING RODS-T3.152.4 ENGINE	4
CYLINDER HEAD-T3.152.4 ENGINE	5
ROCKER SHAFT-T3.152.4 ENGINE	6
TIMING GEAR AND CAMSHAFT-T3.152.4 ENGINE	7
FUEL INJECTION EQUIPMENT-T3.152.4 ENGINE	8
LUBRICATING OIL SUMP-T3.152.4 ENGINE	9
LUBRICATING OIL FILTER AND INTEGRAL COOLER-T3.152.4 ENGINE	10
WATER PUMP, THERMOSTAT AND HEAT EXCHANGER-T3.152.4 ENGINE	11
FUEL SYSTEM AND FILTER-T3.152.4 ENGINE	12
TURBOCHARGER-T3.152.4 ENGINE	13
TURBOCHARGER-T3.152.4 ENGINE	14
TURBOCHARGER-T3.152.4 ENGINE	15
ALTERNATOR POSITIONER-T3.152.4 ENGINE	16
JOINTS AND GASKETS-T3.152.4 ENGINE	17
HEATER KIT-COLD CLIMATE	18
ALTERNATOR	19
ALTERNATOR	20
ALTERNATOR-ISKRA TYPE	21
STARTER MOTOR-MARELLI TYPE	22
STARTER MOTOR-ISKRA TYPE	23
STARTER MOTOR-BOSCH	24
COOLING SYSTEM-FAN AND HOSES	25
COOLING SYSTEM-RADIATOR AND BRACKET	26
FUEL SYSTEM	27
FUEL TANK	28
DRY AIR FILTER-DRY AIR CLEANER	29
EXHAUST SYSTEM	30
EXHAUST SYSTEM	31
TURBOCHARGER-WITH EXHAUST HORIZONTAL	32
THROTTLE CONTROLS	33
THROTTLE CONTROLS	34
BATTERY	35
INSTRUMENT PANEL AND INSTRUMENTS	36
INSTRUMENT PANEL AND INSTRUMENTS	37
ELECTRONIC HARNESS	38
ELECTRICAL WIRING-FRONT	39
ELECTRICAL WIRING-REAR	40
LIGHTING EQUIPMENT	41
LIGHTING EQUIPMENT	42
CLUTCH-0.M.G. - 11	43
CLUTCH-LUK - 11	44
CLUTCH PEDAL AND LINKAGE	45
LOWER CLUTCH P.T.O.	46
CENTRE AXLE HOUSING AND TRANSMISSION HOUSING	47
CENTRE AXLE HOUSING AND TRANSMISSION HOUSING	48
TRANSMISSION	49
TRANSMISSION	50
SHIFT LEVERS	51
GEAR BOX-FOR SHUTTLE VERSION ONLY.	52
REDUCER OPTION-FOR SHUTTLE VERSION ONLY.	53
GEAR BOX-FOR SHUTTLE VERSION ONLY.	54
GEAR BOX-FOR SPECIAL OPTIONS VERSION ONLY	55
REDUCER OPTION-OVERDRIVE AND SHUTTLE VERSION	56
REDUCER OPTION-OVERDRIVE AND UNDERDRIVE VERSION	57
REDUCER OPTION-OVERDRIVE AND CREEPER VERSION	58
REDUCER OPTION-UNDERDRIVE AND SHUTTLE VERSION	59
REDUCER OPTION-UNDERDRIVE E CREEPER VERSION	60
REDUCER OPTION-SHUTTLE AND CREEPER VERSION	61
PTO SHAFT-STANDARD	62
PTO SHAFT-540/750/1000 R.P.M.	63
PTO-CONTROL-STANDARD	64
PTO-CONTROL-540/750/1000 R.P.M.	65
TRANSFER GEAR BOX AND DRIVE SHAFT:	66

TABLE OF CONTENT

4 WHEEL DRIVE CONTROLS	67
REAR AXLE	68
REAR AXLE	69
DIFFERENTIAL LOCK MECHANISM	70
DIFFERENTIAL LOCK MECHANISM	71
BRAKE AND CONTROLS-PEDALS	72
BRAKE AND CONTROLS-PIPINGS	73
BRAKES AND CONTROLS	74
BRAKES	75
MASTER CYLINDER-BRAKE PUMP	76
BRAKE CYLINDER	77
TRAILER BRAKES-FRANCE TYPE	78
TRAILER BRAKES-ITALY TYPE	79
REAR WHEELS	80
WHEELS FRONT	81
FRONT AXLE 2 WHEEL DRIVE	82
FRONT AXLE 4 WHEEL DRIVE	83
FRONT AXLE 4 WHEEL DRIVE-WITH DISCBRAKES	84
FRONT AXLE 4 WHEEL DRIVE	85
FRONT AXLE 4 WHEEL DRIVE	86
FRONT AXLE 4 WHEEL DRIVE	87
STEERING HYDRAULIC LINES	88
STEERING HYDRAULIC LINES	89
STEERING ORBITROL UNIT-2 WHEEL DRIVE	90
STEERING ORBITROL UNIT-4 WHEELS DRIVE	91
STEERING-PUMP-TUROLLA	92
STEERING-PUMP-BOSCH	93
STEERING CYLINDER	94
STEERING CYLINDER	95
HYDRAULIC EQUIPMENT-HYDRAULIC LINES STD.	96
HYDRAULIC EQUIPMENT-WITH REAR AND FRONT CONTROL VALVE	97
HYDRAULIC PUMP-TUROLLA	98
HYDRAULIC PUMP-BOSCH	99
HYDRAULIC PUMP-TUROLLA	100
HYDRAULIC PUMP-BOSCH	101
HYDRAULIC LIFT VALVE-WITH MECHANICS RISER	102
HYDRAULIC LIFT-WITH MECHANICS RISER	103
HYDRAULIC LIFT-WITH ELECTRONIC LIFT	104
HYDRAULIC LIFT - DETAILS	105
ELECTRICAL WIRING-WITH ELECTRONIC LIFT	106
ELECTRICAL WIRING-WITH ELECTRONIC LIFT	107
ELECTRICAL WIRING-CONTROL PANEL ELECTRONIC LIFT	108
HYDRAULIC LIFT VALVE-WITH ELECTRONIC LIFT	109
HYDRAULIC LIFT CYLINDER	110
MECHANICAL CONTROL LIFT	111
MECHANICAL CONTROL LIFT-INTERMIX	112
MECHANICAL CONTROL LIFT	113
AUXILIARY HYDRAULIC VALVE LINES-TILL TYPE	114
AUXILIARY HYDRAULIC VALVE LINES-TILL TYPE	115
AUXILIARY HYDRAULIC VALVE LINES-THIRD DISTRIBUTOR TILL	116
AUXILIARY HYDRAULICS-CONTROL FOR 1.0 DISTRIBUTOR	117
AUXILIARY HYDRAULICS-CONTROL WITH 1.0 AND 2.0 DISTRIBUTOR.	118
AUXILIARY HYDRAULICS-CONTROL FOR 3.0 DISTRIBUTOR TILL	119
AUXILIARY HYDRAULICS VALVE STANDARD-UP TO SERIAL N.B32126	120
AUXILIARY HYDRAULICS VALVE STANDARD-FROM SERIAL N.B32127	121
AUXILIARY HYDRAULICS FLOATING-UP TO SERIAL N.B32126	122
AUXILIARY HYDRAULICS FLOATING-FROM SERIAL N.B32127	123
AUXILIARY HYDRAULIC VALVE LINES-WITH 1.0 DISTRIBUTOR	124
AUXILIARY HYDRAULIC VALVE LINES-WITH 2.0 DISTRIBUTORES	125
AUXILIARY HYDRAULIC VALVE LINES-WITH 3.0 DISTRIBUTORES	126
AUXILIARY HYDRAULIC VALVE LINES-WITH 4.0 DISTRIBUTORES	127
AUXILIARY HYDRAULICS-CONTROL WITH 1.0 AND 2.0 DISTRIBUTOR.	128
AUXILIARY HYDRAULICS-CONTROL FOR 3.0 DISTRIBUTOR - HIDROIRMA	129
AUXILIARY HYDRAULICS-CONTROL FOR 4.0 DISTRIBUTOR -HIDROIRMA	130
CONTROL VALVE-HYDROIRMA TYPE FOR REAR CONTROL VALVE	131
CONTROL VALVE-HYDROIRMA TYPE FOR REAR AND FRONT CONTROL VAL	132
AUXILIARY HYDRAULICS VALVE STANDARD-HYDROIRMA TYPE STANDARD	133
AUXILIARY HYDRAULICS VALVE STANDARD-HYDROIRMA TYPE STANDARD	134

TABLE OF CONTENT

AUXILIARY HYDRAULICS FLOATING-HYDROIRMA TYPE FLOATING	135
AUXILIARY HYDRAULICS FLOATING-HYDROIRMA TYPE FLOATING	136
.-HIDROIRMA TYPE.	137
.-HIDROIRMA TYPE.	138
UPPER AND LOWER LINKS AND RELATED PARTS	139
LINKAGE-QUICK ATTACH	140
LINKAGE-QUICK ATTACH	141
LINKAGE-QUICK ATTACH-DETAILS	142
LINKAGE-QUICK ATTACH	143
SHEET METAL	144
SIDE COVER-SHIELD FAN	145
SHEET METAL	146
SHEET METAL	147
SHEET METAL-CLADDING PLATFORM	148
SHEET METAL-CLADDING PLATFORM	149
BALE EJECTOR KIT	150
BALE EJECTOR KIT	151
BALE EJECTOR KIT	152
SUPPORTS PLATFORM	153
SHEET METAL-CLADDING PLATFORM	154
SHEET METAL-CHASSIS AND SUSPENSION	155
FENDERS - FRONT-4 WHEEL DRIVE	156
SEAT	157
SEAT	158
SEAT	159
SEAT	160
DRIVER SEAT	161
TRACTOR CAB	162
TRACTOR CAB-FRONT - WINDSCRENN	163
TRACTOR CAB-LOWER FIXED COMPONENTS	164
TRACTOR CAB	165
TRACTOR CAB-REAR AND BRACKET	166
TRACTOR CAB-LEFT SIDE - RIGHT SIDE	167
TRACTOR CAB-OUTSIDE AND INTERNAL	168
ROTATING LIGHT	169
WEIGHT FRAME AND WEIGHTS W	170
REAR HITCH	171
REAR HOOK-STANDARD	172
DRAWBAR-HEAVY DUTY	173
REAR HOOK-WITH 6 POSITIONS	174
REAR HITCH	175
TOOL KIT	176

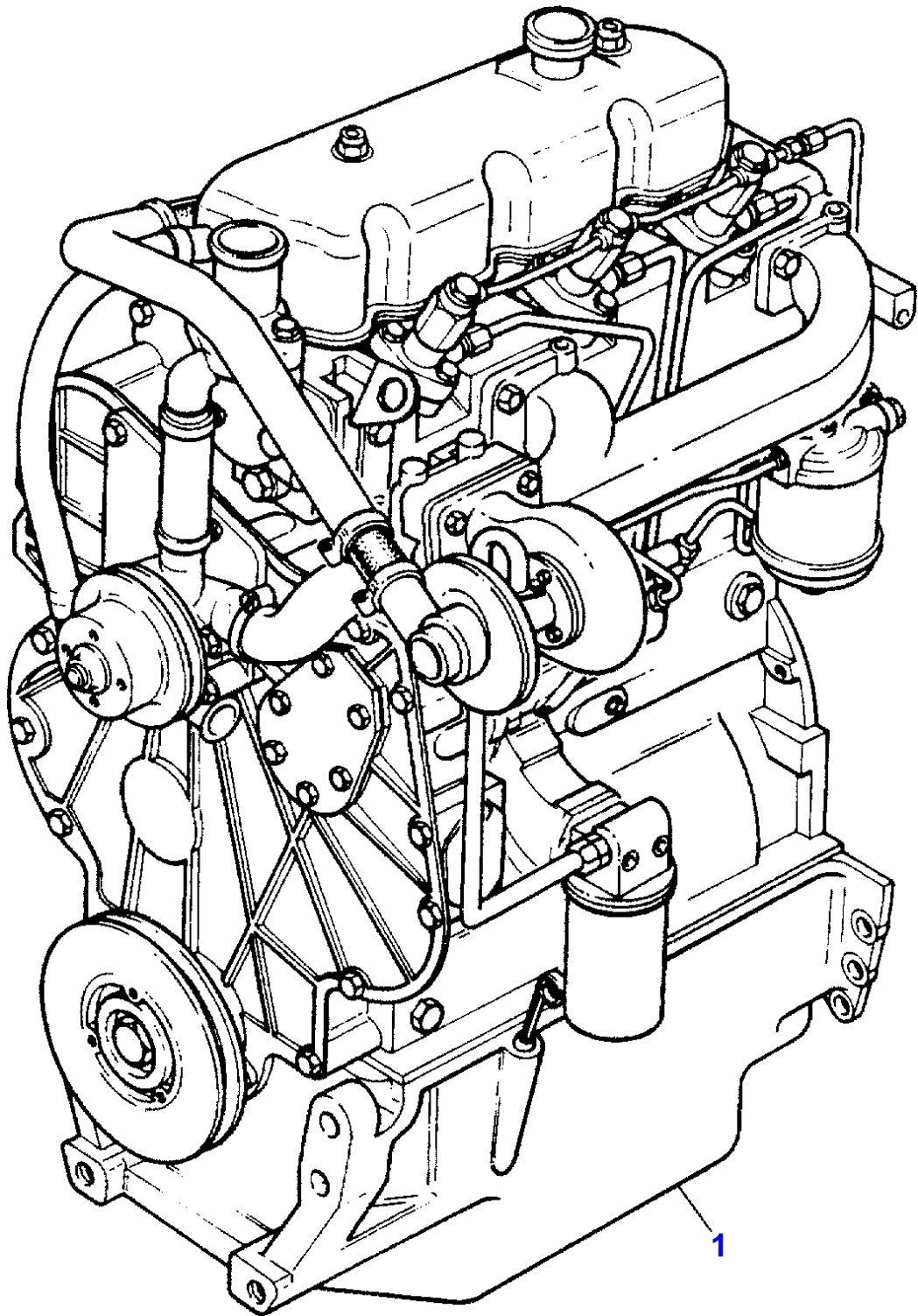

MASSEY FERGUSON

MF 364 FQ CAB TRACTOR - 3540967

3540967

ENGINE ASSEMBLY-T3.152.4 ENGINE

1

Item	Part Number	Qty	Description	Comments
1	3553117M91	1	Engine	[C] "CN31198"
1	3553116M91	1	Engine	[D] "CN31225"
				[C] STD.HYDRAULIC LINES
				[D] SINGLE HYDRAULIC LINES

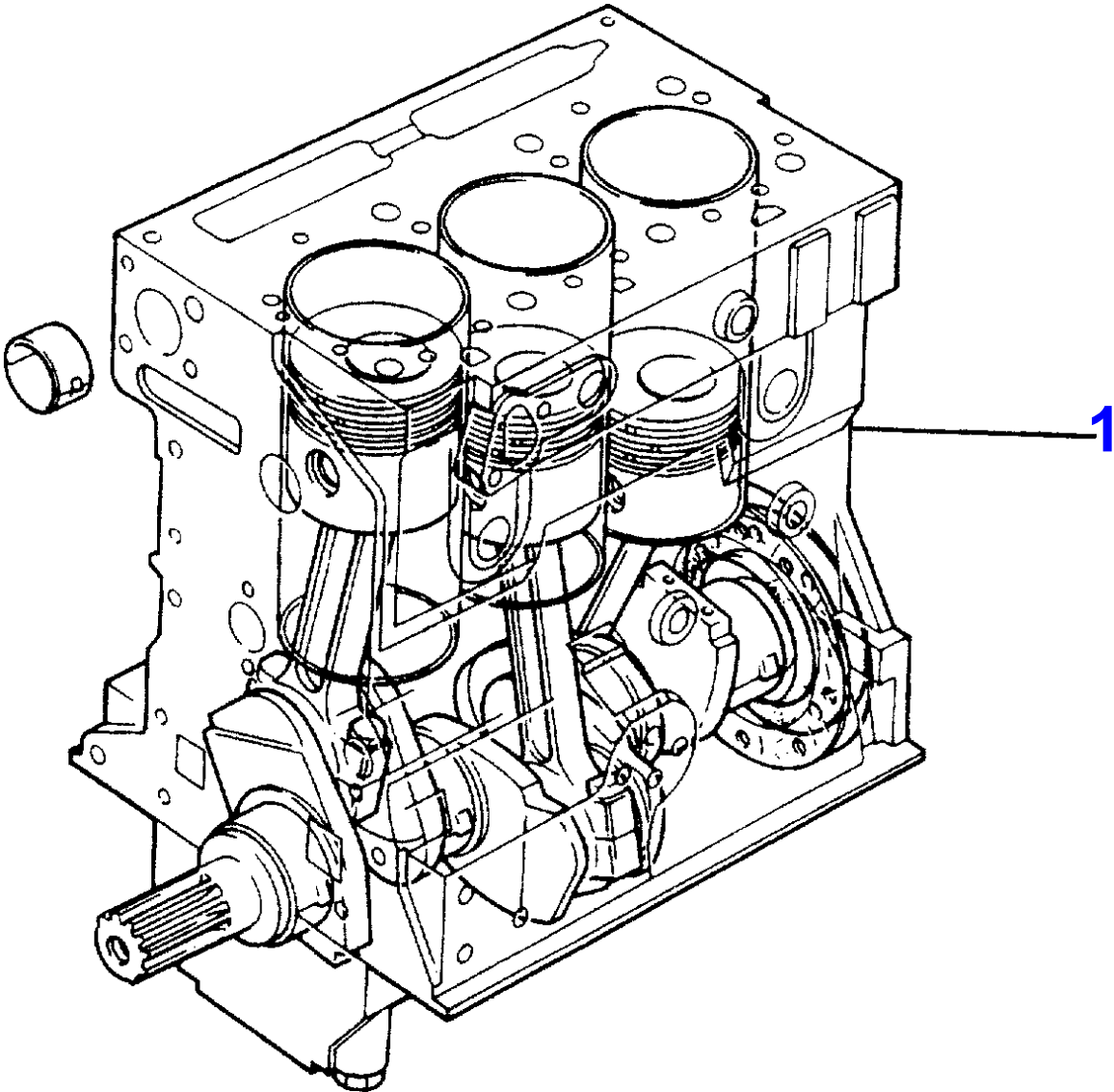

SHORT ENGINE-TABLE PK ACEC9107

Item	Part Number	Qty	Description	Comments
1	CN39125	1	SHORT ENGINE	[A] "CN39117"
2		1	HOUSING	[B]
		3	LINER	(1)
		1	ALBERO A	(1)
		2	WEIGHT	(1)
		1	ALBERO A	(1)
		3	PISTON	(1)
		3	ALBERO A	(1)
		3	CONROD	(1)
		1	ALBERO A	(1)
		4	WASHER	(1)
		1	SEAL	(1)
		1	HOUSING	(1)
				[A] LIP SEAL
				[B] COMPLETE WITH PLUGS

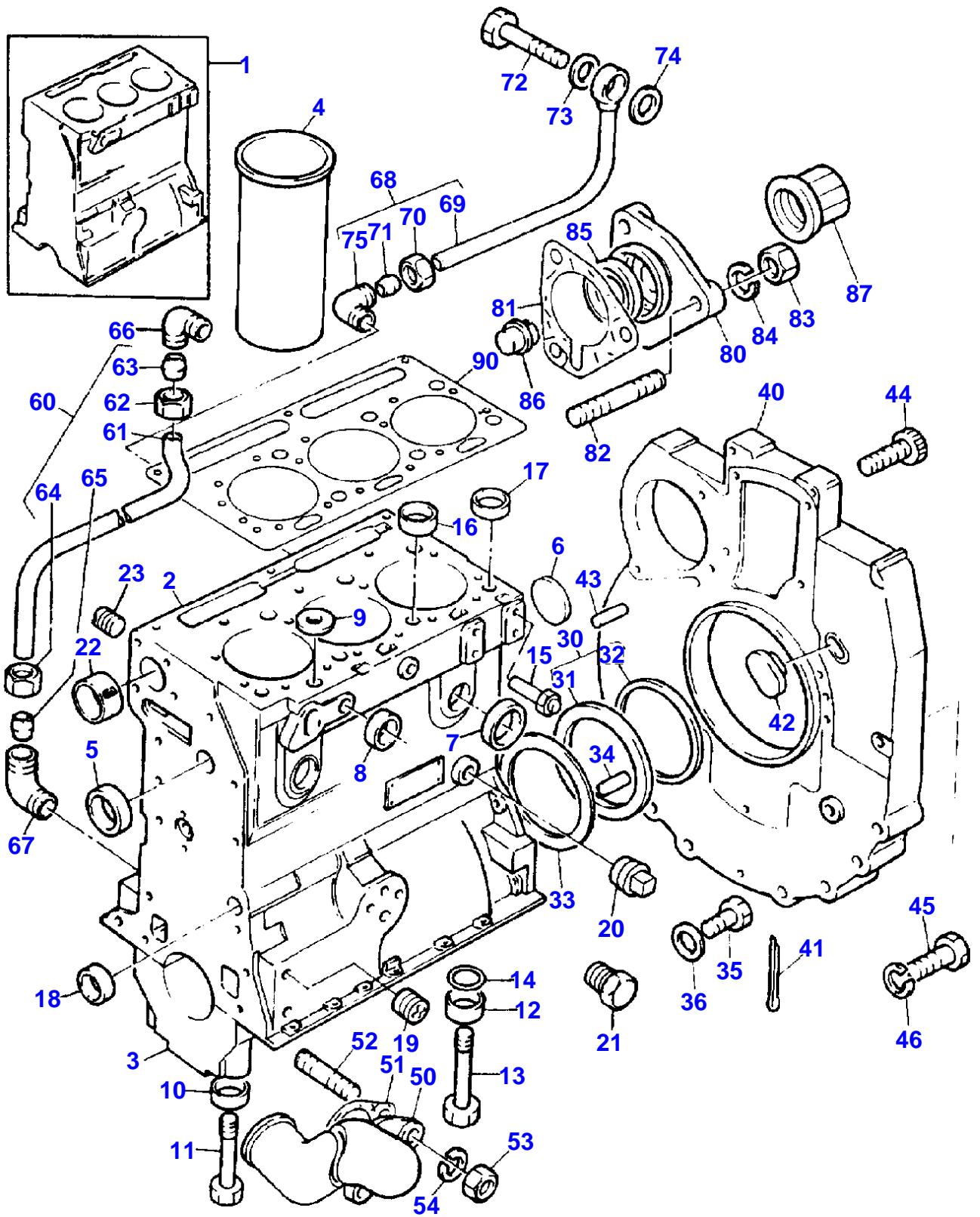

CYLINDER BLOCK-T3.152.4 ENGINE

Item	Part Number	Qty	Description	Comments
1	ZZ 50133	1	BLOCK	Up to Serial or Engine Number
	ZZ 50206	1	BLOCK	From Serial or Engine Number
2		1	CYLINDER BLOCK	(1)
3		4	SUPPORT	Not serviced, order REF.1 (1)
4	31358323	3	Liner	Not serviced, order REF.1 [A, X] (1)
4	31358345	X	Liner	[B]
	31358357	X	Liner	[B] Thickness (+)0.76MM Thickness (+)0.030
5	0650710	1	Plug	(1)
6	0650692	1	Plug	(1)
7	0650710	4	Plug	(1)
8	32417163	2	Plug	(1)
9	33141124	1	Plug	(1)
10	33137408	6	Thimble	(1)
11	32181441	6	Screw	(1)
12	33137408	2	Thimble	(1)
13	32181442	2	Screw	(1)
14	2415608	2	O Ring	(1)
15	2485A204	1	Plug	(1)
16	33157142	2	Plug	(1)
17	33157143	2	Plug	(1)
18	0650566	2	Plug	(1)
19	32114472	3	Plug	(1)
20	0650593	1	Plug	(1)
20	0650594	1	Plug	Up to Serial or Engine Number U726816K [D] From Serial or Engine Number U726817K
21	32161114	1	Plug	(1)
22	32114143	1	Plug	(1)
23	31134128	1	Bush	(1)
30	4142V002	1	Housing	[X]
31		1	RING	. 1. 2. 4 (30) Not serviced, order REF.30
32	2418F475	1	Seal	(30)
33	33826115	1	GASKET	[X] . 1. 2. 4
34	0350015	2	Dowel	
35	2183205	9	Screw	
36	390972X1	9	Washer Metric	
40	37147975	1	Plate	
41	0610045	1	Pin	
42	37813113	1	Plug	
43	0350016	2	Dowel	
44	0720798	2	Screw	
45	0746454	6	BOLT	
46	0920054	6	Washer	
50	3765T011	1	Connection	
51	3686J003	1	GASKET	
52	2217072	2	Stud	
53	0576002	2	Nut	
54	0920053	2	Washer	
60	35352404	1	Pipe,Oil	
61		1	PIPE	(60) Not serviced, order REF.60
62	0576111	1	Nut	(60)
63	0566002	1	Olive	(60)
64	0576111	1	Nut	(60)
65	0566002	1	Olive	(60)
66	0201047	1	Connection	
67	0201047	1	Connection	
68	35568109	1	Pipe,Oil	
69		1	PIPE	(68) Not serviced, order REF.68
70	0576111	1	Nut	(68)

CYLINDER BLOCK-T3.152.4 ENGINE

Item	Part Number	Qty	Description	Comments
71	0566002	1	Olive	(68)
72	0095350	1	Bolt	
73	2411118	1	Washer	
74	2411118	1	Washer	
75	0201047	1	Connection	
80	37556191	1	Plate	[E]
81	36862605	1	GASKET	
82	2183205	3	Screw	[F]
82	2183203	3	Screw	[G]
83	0920053	3	Washer	
90	3681E024	1	GASKET	[X] . 4. 4. 8
				[B] SLIP FIT
				[A] PRESS FIT
				[C] REMOVE AND FIT 0650594
				[D] FITTED IN PLACE OF OIL PRESSURE RAIL PLUG SUPPLIE WITH CYLINDER BLOCK ASSEM
				[E] WAS 37416753 - USE 37556191 WITH 2183203-3
				[F] USED ONLY WITH 37416753
				[G] USED ONLY WITH 37556191
				[X] QTY PER TRACTORS SOLD (AA.BBB.CCC.DDD) (AA) FOR ,(BBB) 2-10 (CCC) 11-25 (D DD) 26-50

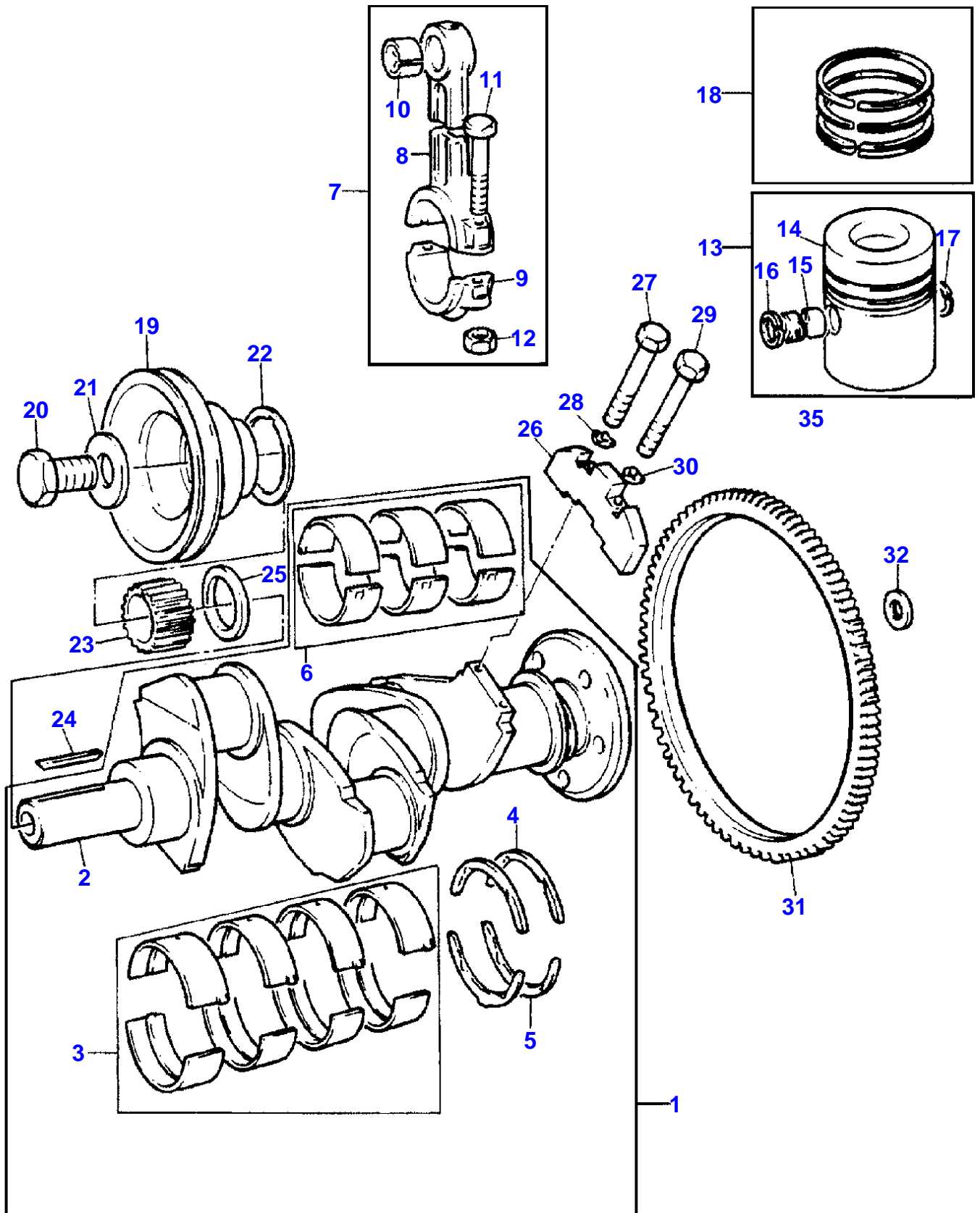

CRANKSHAFT, PISTONS AND CONNECTING RODS-T3.152.4 ENGINE

Item	Part Number	Qty	Description	Comments
1	ZZ90106	1	SHAFT	
2		1	SHAFT	(1) Not serviced, order REF.1
3	U5MB0008	1	KIT	[A, X] . 1. 2. 3
3	68084A	X	Kit, Bearing	[A] Thickness (-)0.25MM Thickness (-)0.010 U5MB0008A
3	U5MB0008B	X	KIT	[A] Thickness (-)0.50MM Thickness (-)0.020
3	U5MB0008C	X	KIT	[A] Thickness (-)0.75MM Thickness (-)0.030
4	31137211	2	Thrust Washer	[X] (1) . 1. 2. 3
4	31137212	X	Washer	Thickness (+)0.19MM Thickness (+)0.0075
5	31137221	2	Thrust Washer	[X] (1) . 1. 2. 3
5	31137222	X	Washer	Thickness (+)0.19MM Thickness (+)0.0075
6	U5ME0005	1	KIT	[A, X] (1) . 1. 2. 3
6	U5ME0005A	X	KIT	[A] Thickness (-)0.25MM Thickness (-)0.010
6	U5ME0005B	X	KIT	[A] Thickness (-)0.50MM Thickness (-)0.020
6	U5ME0005C	X	KIT	[A] Thickness (-)0.75MM Thickness (-)0.030
7	ZZ90010	1	Kit, Conrod	[X] . 3. 6. 9
8		1	CONROD	(7) Not serviced, order REF.7
9		1	SUPPORT	(7) Not serviced, order REF.7
10	31134151	1	Bush	(7)
11	0095250	2	Bolt	(7)
12	33221327	2	Nut	(7)
13	U5LP0029	3	Kit, Piston	[B]
	U5LU0023	3	Kit, Piston	[C, X] . 3. 6. 9
14		1	PISTON	(13) Not serviced, order REF.13
15		1	PIN	(13) Not serviced, order REF.13
16	0170001	1	Circlip	(13)
17	0170001	1	Circlip	(13)
18	4181A017	3	Kit, Piston Ring	[X] . 3. 6. 9
19	31147788	1	PULLEY	
20	32162331	1	Screw	
21	33125112	1	Washer	
22	33176137	1	Washer	
23	31163495	1	GEAR	[D, G] Number of teeth/spines 25
23	31163495	1	GEAR	[E, H] Number of teeth/spines 25
24	36271704	1	Woodruff Key	
25	33125151	1	SPACER	
26	31328242	2	Weight	[F]
27	2185189	2	Screw	
28	31731515	2	Washer	Right Hand
29	2185189	2	Screw	
30	31731516	2	Washer	Left Hand
31	3552228M1	1	CROWNWHEEL	Number of teeth/spines 115

Item	Part Number	Qty	Description	Comments
32	33117127	6	Washer	

[B]
UNTOPPED
[A]
PRE-FINISHED
[C]
PRE-TOPPED
[D]
FOR ENGINES BUILT TO BUILD LIST CN31198 (3553117M 1).
[E]
FOR ENGINES BUILT TO BUILD LIST CN31225 (3553116M 1).
[F]
REPLACES 31328241 IN ENGINE SETS ONLY(QTY 2).
[G]
STD.HYDRAULIC LINES
[H]
SINGLE HYDRAULIC LINES
[X]
QTY PER TRACTORS SOLD (AA.BBB.CCC.DDD) (AA) FOR ,(BBB) 2-10 (CCC)
11-25 (D DD) 26-50

Buy Now



Our support email:

ebooklibonline@outlook.com