

Page Title	Page Number
Engine - Cylinder Head	010-0005
Engine - Cylinder Head Cover	010-0010
Engine - Intake Manifold	010-0015
Engine - Exhaust Manifold	010-0020
Engine - Cylinder-Block	010-0025
Engine - Connecting Rod Bearings - Optional	010-0030
Engine - Oil Sump	010-0035
Engine - Rear Plate	010-0040
Engine - Timing Gear Housing - E3CDVB43	010-0045
Engine - Timing Gear Housing - E3CDWB20	010-0050
Engine - Hanger	010-0055
Engine - Rocker Arm	010-0060
Engine - Camshaft	010-0065
Engine - Piston	010-0070
Engine - Crankshaft - E3CDWB20	010-0075
Engine - Crankshaft - E3CDVB43	010-0080
Engine - Oil Pump	010-0085
Engine - Water Pump - E3CDWB20 - E3CDVB43	010-0090
Engine - Fan	010-0095
Engine - Injection System	010-0100
Engine - Injection System - Injection Nozzle	010-0105
Engine - Injection Pump	010-0110
Engine - Fuel Pipe	010-0115
Adaptor	010-0120
Engine Electrics	010-0125
Engine - Injection Pump	010-0130
Engine - Repair Kit	010-0135

I-IS01-002-B

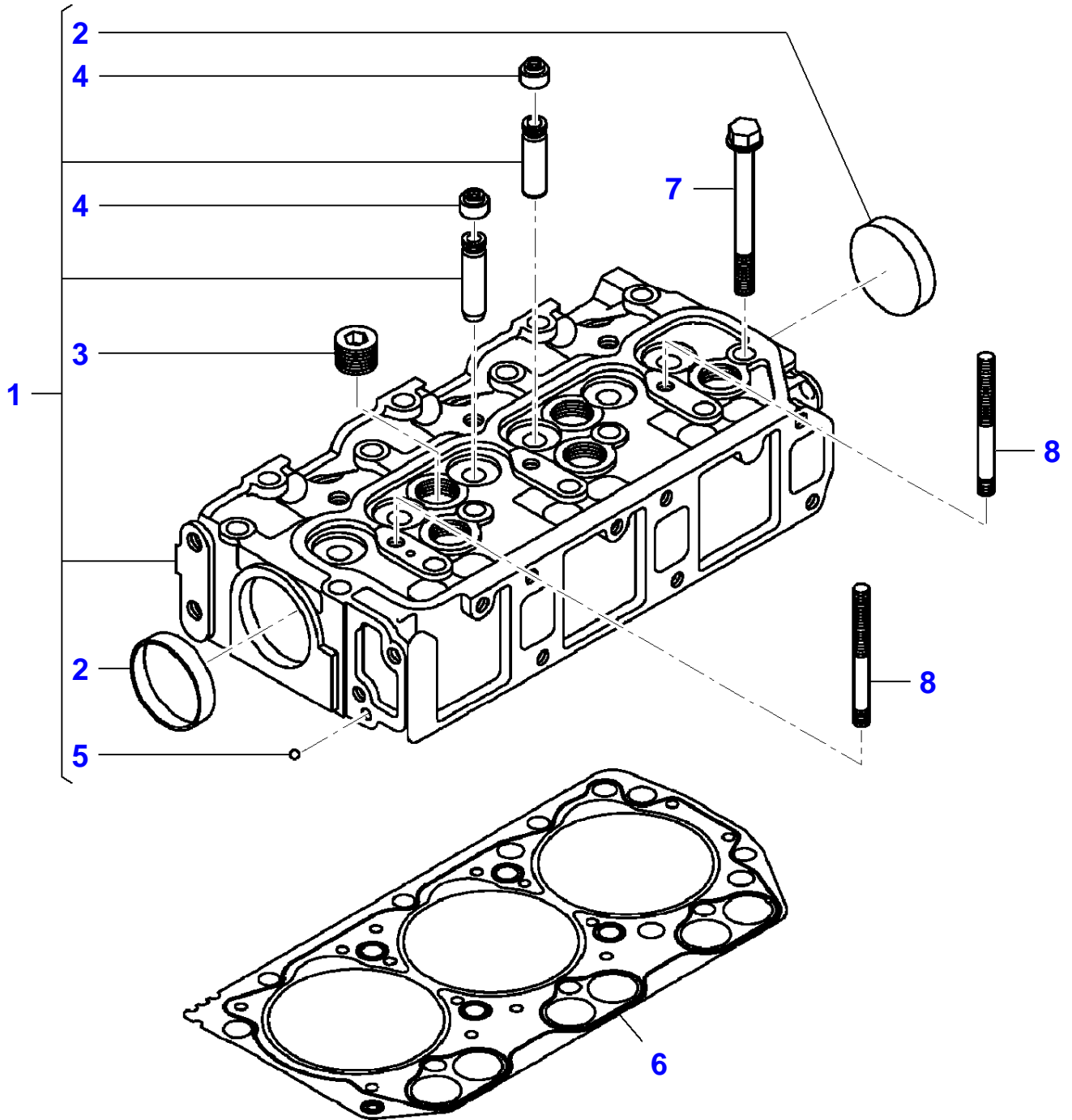

**Massey Ferguson****MF 1531 COMPACT TRACTOR - 3906057****3906057****Engine - Cylinder Head****Page010-0005**

<b>Item</b>	<b>Part Number</b>	<b>Qty</b>	<b>Description</b>	<b>Comments</b>
1	4265866M95	4	Kit, Cyl. Head	
2	3710542M1	2	Cup	(1) Diameter 50 mm
3	3707877M2	5	Pipe Plug	(1)
4	3710256M1	6	Oil Seal	(1)
5	3711713M1	1	Ball	(1)
6	6242056M2	1	Head Gasket	
7	3710536M1	14	Hex Head Bolt	
8	3607420M1	2	Stud Bolt	

I-IS02-004-A

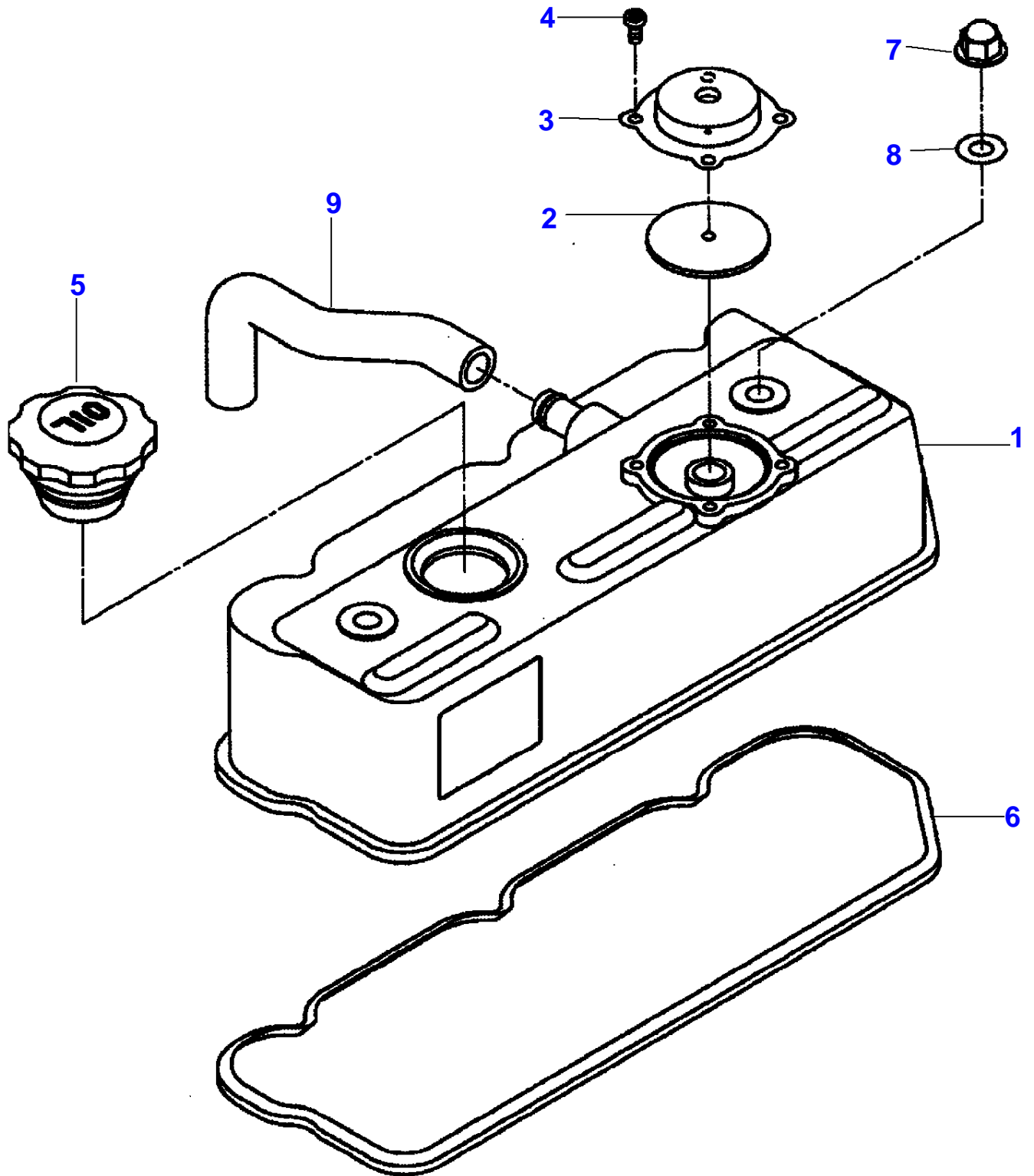

Engine - Cylinder Head Cover

Item	Part Number	Qty	Description
1	3608540M92	1	Valve Cover
2	3710554M1	1	Rubber
3	3710561M1	1	Cover
4	3710529M1	4	Hex Head Bolt
5	<b>3710188M1</b>	1	Plug
6	<b>3710553M1</b>	1	Seal
7	3710127M2	2	Blind Nut
8	4267629M1	2	Seal
9	6242049M2	1	Rubber Hose

Thank you so much for reading.  
Please click the “Buy Now!”  
button below to download the  
complete manual.



After you pay.

You can download the most  
perfect and complete manual in  
the world immediately.

Our support email:

[ebooklibonline@outlook.com](mailto:ebooklibonline@outlook.com)