

Page Title	Page Number
Knives And Fingers - Freeflow - 20-22'	001-0001
Table Auger Right Hand - Freeflow - 20-22'	001-0002
Table Auger Left Hand - Freeflow - 20-22'	001-0003
Guarding And Transmissions - Freeflow - 20-22'	001-0004
Table Housing And Guarding - Freeflow - 20-22'	001-0005
Knives And Fingers - Powerflow - 18'-20'-22'	001-0006
Table Auger Right Hand - Powerflow - 18'-20'-22'	001-0007
Tabel Auger Left Hand - Powerflow - 18'-20'-22'	001-0008
Guarding And Transmissions - Powerflow - 20' + (22' up to No 939566)	001-0009
Table Housing And Guarding - Powerflow - 20-22' - From 942482	001-0010
Table Housing And Guarding - Powerflow - 20-22' Up To 942481	001-0011
Knives And Fingers - Powerflow - 25'	001-0012
Feeder Drum Right Hand - Powerflow - 25'	001-0013
Feeder Drum Left Hand - Powerflow - 25'	001-0014
Guarding And Transmissions - Powerflow - 22' - From 939567 + 25'	001-0015
Table Housing And Guarding - Powerflow - 25' - From 942482	001-0016
Table Housing And Guarding - Powerflow - 25' - Up To 942481	001-0017
Powerflow Band - Rear - 18'-20'-22'	001-0018
Powerflow Band - Front - 18'-20'-22'	001-0019
Powerflow Band - Rear - 25'	001-0020
Powerflow Band - Front - 25'	001-0021
Oilseed Rape Auger - From Serial No 942482	001-0022
Oilseed Rape Auger - Up To 942481	001-0023
Straw Dividers - FROM 61365 - UP TO 62017	001-0024
Straw Dividers - FROM 62018	001-0025
Straw Dividers - UP TO 61364	001-0026
Table Trailer - From No 0000500	001-0027
Table Trailer - UP TO NO. 7374033	001-0028
Table Trailer - With Trailor Braking - World Wide Hook Up - From Serial No 942482	001-0029
Lightening Bracket - UP TO NO. 7374033	001-0030
Electric Vertical Knife	001-0031
Decals	001-0032
Multi-Coupling	001-0033

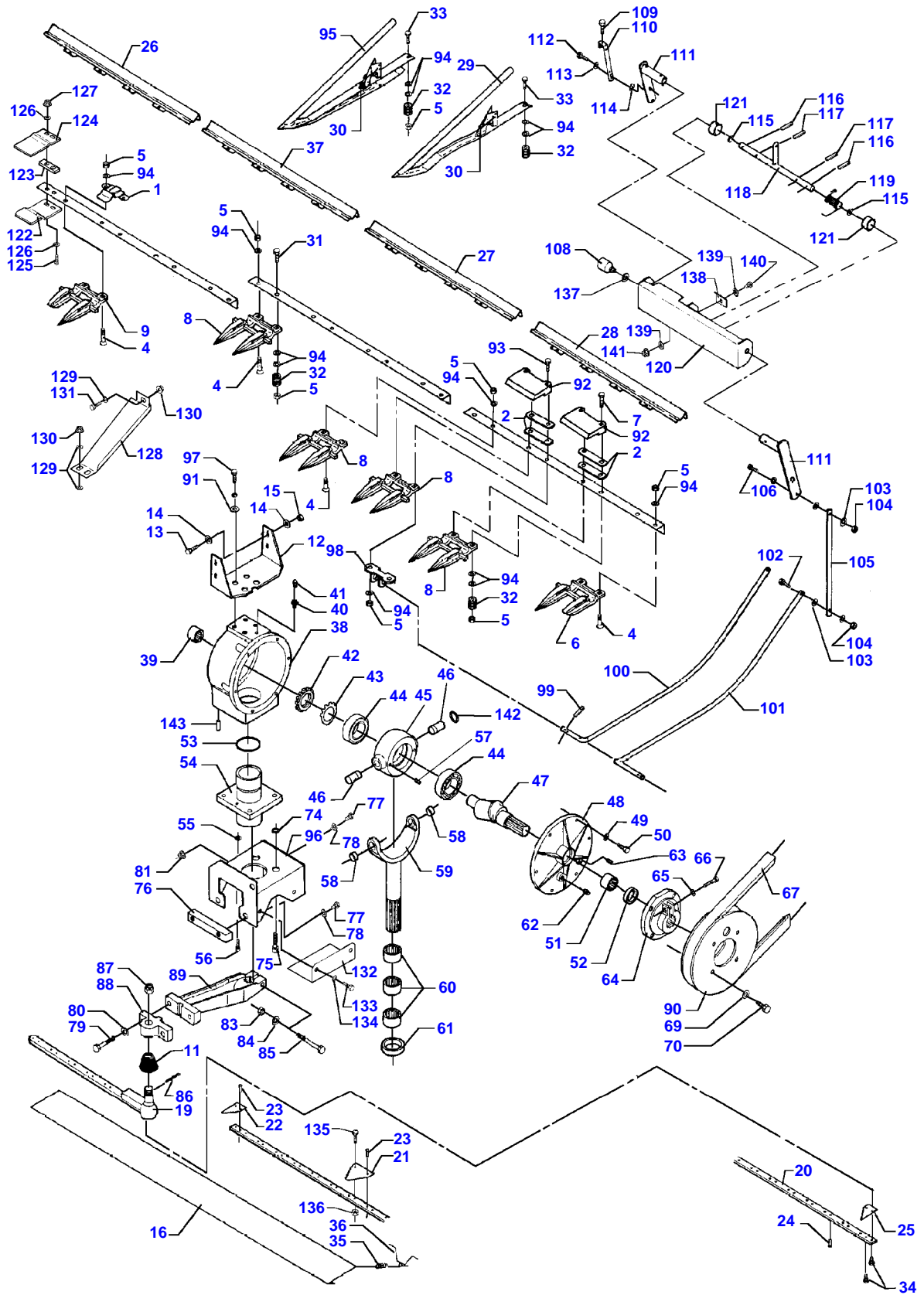

Item	Part Number	Qty	Description	Comments
1	D28283934	19	Clip	20' - 6,16M
	D28283934	21	Clip	22' - 6,77M
2	D28230292	4	Shim	
4	D40551500	X	Bolt	
5	D41010800	X	Nut	
6	D44104700	1	Finger	Left Hand
7	D40067600	X	Screw	
8	D44104500	39	Finger	20' - 6,16M
	D44104500	43	Finger	22' - 6,77M
9	D44104600	1	Finger	Right Hand
11	D44120500	1	Cap	
12	D28283104	1	Support	Up to Serial or Engine Number 939559
13	339337X1	2	Hex Cap Screw	M8 X 30
14	D20400414	4	Washer	
15	394367X1	2	Locknut	
16	D28230830	2	Guard	22' - 6,77M
	D28230831	1	Guard	20' - 22' 6,16M - 6,77M
	D28200314	1	Guard	20' - 6,16M
	D28200738	1	Guard	20' - 6,16M
19	D28283010	2	Knife Back	20' - 6,16M
	D28283865	2	Blade	22' - 6,77M
	D28283011	2	Toggle	
20	D28281492	2	Knife Back	20' - 6,16M
	D28281493	2	Knife Back	22' - 6,77M
21	D44103700	X	Tr Knife Blades	[D]
22	D44103800	2	Half Section	
23	D41306100	X	Rivet	[D]
24	D41306200	X	Rivet	[D]
25	D44104000	2	Half Section	Left Hand
26	D18283701	1	Stone Trap	
27	D18283705	1	Stone Trap	22' - 6,77M
	D18283706	1	Stone Trap	20' - 6,16M
28	D18283702	1	Stone Trap	
29	D49040900	X	Ear Lifter	
30	D49040400	X	Spring	
31	339019X1	X	Hex Cap Screw	M10 X 50
32	D49040600	X	Roller	
33	339019X1	X	Hex Cap Screw	M10 X 50
34	339560X1	2	Hex Cap Screw	M6 X 16
35	D26500317	2	Spring	(16)
36	D28230841	2	Spring	(16)
37	D18283704	1	Stone Trap	22' - 6,77M
38	D28281324	1	Wobble Drive	[B] Cpl. (38)
	D44127800	1	Box	[B] (38)
	D28281324	1	Wobble Drive	[C] (38) Cpl.
	D44126500	1	Box	[C] (38)
39	D44128800	1	Bearing Needle	(38)
40	D44129400	1	Connector	(38)
41	D46116500	1	Valve	(38)
42	D44129100	1	Nut	(38)
43	D44129200	1	Washer	(38)
44	D41668400	2	Roller Bearing	(38)
45	D44127900	1	Housing	[B] (38)
	D44126400	1	Housing	[C] (38)
46	D44128000	2	Journal	[B] (38)
	D44125900	1	Journal	[C] (38)
47	D44129300	1	Shaft	(38)
48	D44128200	1	Cover	[B] (38)
	D44126300	1	Cover	[C] (38)

Item	Part Number	Qty	Description	Comments
49	D41102100	6	Washer	(38) A8
50	339123X1	6	Hex Cap Screw	(38) M8 X 20
51	D41669700	1	Bearing Needle	(38)
52	D45412000	1	Gasket	(38)
53	D45481500	1	O Ring	(38)
54	D44128300	1	Bearing Carrier	[B] (38)
54	D44126200	1	Bearing Carrier	[C] (38)
55	D41102100	2	Washer	(38) A8
56	D40697200	2	Screw	[B] (38)
56	D40697700	2	Screw	[C] (38)
57	D40639600	2	Pin	[B] (38)
58	D44128400	2	Bush	[B] (38)
58	D44126100	2	Bush	[C] (38)
59	D44128500	1	Yoke	[B] (38)
59	D44126000	1	Yoke	[C] (38)
60	D41669800	3	Bearing Needle	(38)
61	D45409500	1	Gasket	(38)
62	D44128600	1	Plug	(38)
63	D45236200	1	Plug	(38)
64	D44127100	1	Hub	(38)
65	D41100900	1	Spring Washer	(38)
66	D40694000	1	Screw	(38)
67	D41985600	1	Belt	
69	D20400426	4	Washer	
70	1440716X1	4	Hex Cap Screw	M12 X 30
74	D20400523	4	Spacer	
75	D40465400	4	Screw	
76	D28283103	1	Clamp	
77	390419X1	5	Hex Cap Screw	M16 X 40
78	D20400461	5	Washer	
79	D40698400	2	Screw	
80	D20400438	2	Washer	
81	1442739X1	2	Locknut	M16
83	1442190X1	1	Locknut	M12
84	D20400428	1	Washer	
85	390826X1	1	Hex Cap Screw	M12 X 100
86	391423X1	1	Split Pin	Diameter 4 X 40
87	D41054300	1	Nut	
88	D44126900	1	Flange	
89	D44127000	1	Swivel Arm	
90	D44127200	1	Pulley	
91	D28280986	4	Washer	
92	D28260362	X	Clip	
93	1441671X1	X	Screw Special	M10 X 50
94	D20400419	X	Washer	
95	D49040300	X	Ear Lifter	
96	D18283109	1	Support	
97	339337X1	4	Hex Cap Screw	M8 X 30
98	D28284356	4	Union	[A]
99	339662X1	8	Roll Pin	[A] Diameter 6 X 28
100	D28284257	2	Sensor	[A]
101	D28284258	2	Sensor	[A]
102	D40405300	4	Screw	[A]
103	D20400506	20	Washer	[A]
104	394367X1	8	Locknut	[A] M8
105	D28284223	4	Link	[A]
106	339009X1	4	Hex Cap Screw	[A] M8 X 35

Item	Part Number	Qty	Description	Comments
108	D28780523	2	Potentiometer	[A]
109	D40464900	2	Screw	[A]
110	D28780845	2	Rod	[A]
111	D28284225	4	Lever	AUTO LEVEL 22' - 6,77M
111	D28284234	4	Lever	[A]
112	339804X1	2	Hex Cap Screw	[A] M6 X 25
113	D20400404	2	Washer	[A]
114	1441462X1	2	Locknut	[A] M6
115	D28200551	4	Washer	[A]
116	D42611900	8	Pin	[A]
117	339052X1	4	Roll Pin	[A] Diameter 6 X 40
118	D28284232	2	Shaft	[A]
119	D28284389	2	Spring	[A]
120	D28284229	2	Support	AUTO LEVEL 22' - 6,77M
121	D28284456	4	Bush	[A]
122	D28281576	1	Plate	
123	D28281575	1	Chock	
124	D28281574	1	Plate	
125	339010X1	2	Hex Cap Screw	M8 X 40
126	D20400506	2	Washer	
127	394367X1	2	Locknut	M8
128	D28281572	1	Guard	
129	D20400506	3	Washer	
130	D41017500	3	Locknut	
131	339761X1	1	Hex Cap Screw	M8 X 25
132	D28281706	1	Guard	
133	339124X1	2	Hex Cap Screw	M8 X 16
134	D20400506	2	Washer	
135	339560X1	X	Hex Cap Screw	M6 X 16
136	1441462X1	X	Locknut	M6
137	D20400441	1	Washer	
138	D28284268	2	Stop	
139	D20400416	4	Washer	
140	339123X1	2	Hex Cap Screw	M8 X 20
141	394367X1	2	Locknut	M8
142	D45483000	1	O Ring	[C]
143	D42650400	2	Pin	

FOOTNOTE [A] OPTIONAL EQUIPMENT AUTO LEVEL

FOOTNOTE [B] USED ONLY IN KNIFE DRIVES WITH 6 HOLES IN BEARING HOUSING BOTTOM

FOOTNOTE [C] USED ONLY IN KNIFE DRIVES WITH 8HOLES IN BEARING HOUSING BOTTOM AND BULGES SIDES

FOOTNOTE [D] OPTIONAL

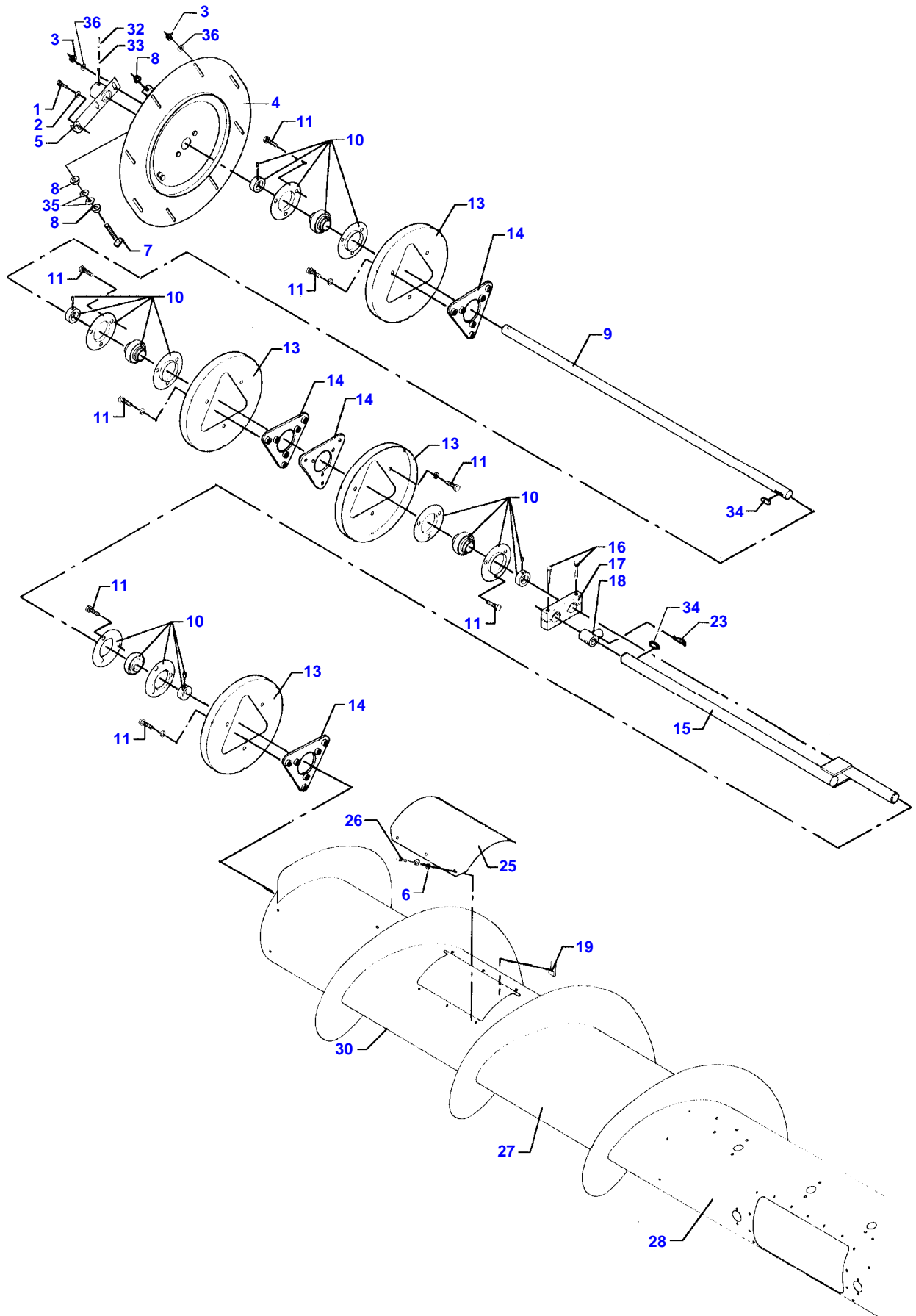

Item	Part Number	Qty	Description	Comments
1	339124X1	1	Hex Cap Screw	M8 X 16
2	D20400506	1	Washer	
3	D41017500	10	Locknut	
4	D18280040	1	Plate	Right Hand
5	D28283029	1	Adjuster	
6	391038X1	6	Flat Washer	
7	D28211023	1	Bolt	
8	1440329X1	2	Locknut	M10
9	D28283037	1	Shaft	20' - 6,16M Up to Serial or Engine Number 940147
	D28283871	1	Shaft	22' - 6,77M Up to Serial or Engine Number 940147
	D28284655	1	Shaft	20' - 6,16M From Serial or Engine Number 940148
	D28284661	1	Crankshaft	22' - 6,77M From Serial or Engine Number 940148
10	D41707800	4	Bearing	
11	339814X1	24	Hex Cap Screw	M10 X 35
13	D28280014	4	Plate	
14	D28283847	4	Bearing Plate	
15	D28285977	1	Crankshaft	
16	3009498X1	2	Hex Cap Screw	M10 X 55
17	D28283039	1	Arm	
18	D28251831	15	Bearing Carrier	
19	D43428200	6	Nut	M6
23	D28283853	15	Hair Pin	
25	D18283070	1	Cover	Up to Serial or Engine Number 939559
	D18285312	1	Cover	From Serial or Engine Number 939560
26	339666X1	6	Hex Cap Screw	M6 X 20
27	D18283125	1	Table Auger	20' - 6,16M Up to Serial or Engine Number 940147
	D18283870	1	Table Auger	22' - 6,77M Up to Serial or Engine Number 940147
	D18285991	1	Table Auger	20' - 6,16M From Serial or Engine Number 940148
	D18285992	1	Table Auger	22' - 6,77M From Serial or Engine Number 940148
28	D28283012	1	Body	
30	D28283034	1	Body	Right Hand 20' - 6,16M Up to Serial or Engine Number 940147
	D28286012	1	Body	Right Hand 20' - 6,16M From Serial or Engine Number 940148
	D28283876	1	Body	Right Hand 22' - 6,77M Up to Serial or Engine Number 940147
	D28286013	1	Body	Right Hand 22' - 6,77M From Serial or Engine Number 940148
32	1441645X1	1	Pin	Diameter 8 X 55
33	D42625300	1	Pin	Diameter 13 X 56
34	339441X1	2	Key Parallel	
35	D20400471	2	Washer	
36	D20400414	X	Washer	

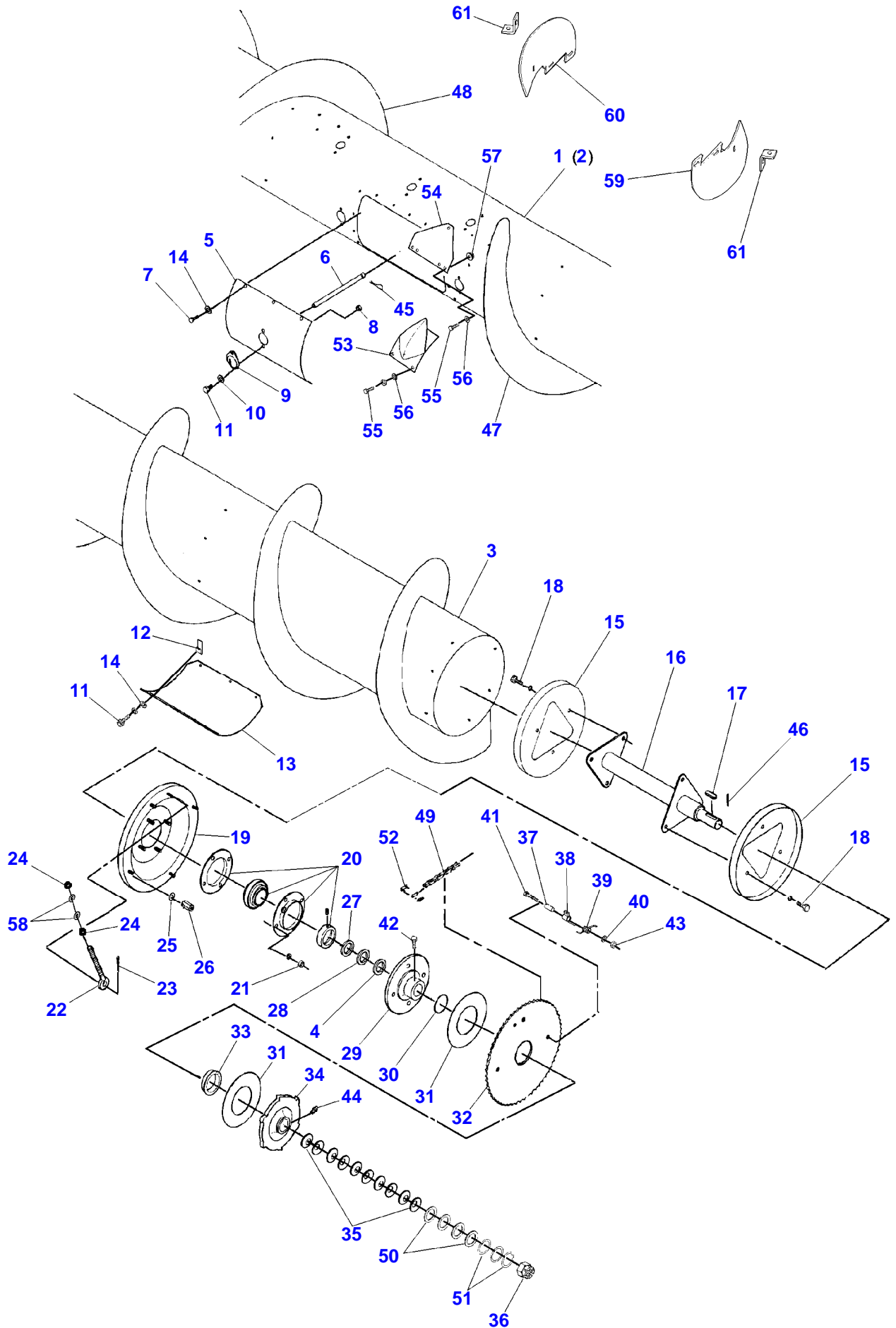

Item	Part Number	Qty	Description	Comments
1	D18283125	1	Table Auger	20' - 6,16M Up to Serial or Engine Number 940147
	D18283870	1	Table Auger	22' - 6,77M Up to Serial or Engine Number 940147
	D18285991	1	Table Auger	20' - 6,16M From Serial or Engine Number 940148
	D18285992	1	Table Auger	22' - 6,77M From Serial or Engine Number 940148
2	D28283012	1	Body	
3	D28283875	1	Body	Left Hand 22' - 6,77M
	D28286006	1	Body	Left Hand 20' - 6,16M
4	D41653500	X	Washer	[A]
5	D18283078	1	Cover	
6	D28283815	15	Finger	
7	339560X1	X	Hex Cap Screw	M6 X 16
8	1441462X1	X	Locknut	M6
9	D28283060	15	Bush	
10	D20400404	X	Washer	
11	339666X1	X	Hex Cap Screw	M6 X 20
12	D43428200	6	Nut	M6
13	D18283070	1	Cover	Up to Serial or Engine Number 939559
	D18285312	1	Cover	From Serial or Engine Number 939560
14	391038X1	6	Flat Washer	
15	D28280014	2	Plate	
16	D28283007	1	Drive Shaft	
17	D43106800	1	Key	
18	3009491X1	6	Hex Cap Screw	M10 X 20
19	D18283053	1	Plate	
20	D41716500	1	Bearing	
21	3009695X1	4	Nut	M12
22	D28281387	1	Screw	
23	339531X1	1	Split Pin	Diameter 4 X 35
24	339402X1	2	Nut	M10
25	D20400415	4	Washer	
26	D28280729	4	Nut	
27	D41653500	X	Washer	
28	D41653500	4	Washer	
29	D28283004	1	Washer	
30	D45481600	1	O Ring	
31	D45904300	2	Friction Disc	
32	D28283008	1	Chain Sprocket	Up to Serial or Engine Number 937852
	D28286047	1	Sprocket	From Serial or Engine Number 937853
33	D28283000	1	Insert	Up to Serial or Engine Number 937852
	D28286049	1	Insert	From Serial or Engine Number 937853
34	D28286166	1	Clutch Disc	
35	D41112400	10	Washer	
36	D41054100	1	Castle Nut	
37	D28281431	1	Spacer	From Serial or Engine Number 940222
	D28282429	1	Bush	From Serial or Engine Number 941444
38	D28281432	1	Support	From Serial or Engine Number 941444
	D28282430	1	Dog	From Serial or Engine Number 940222
39	D28283006	1	Spring	From Serial or Engine Number 940222
	D28282433	1	Spring	From Serial or Engine Number 941444
40	390734X1	1	Flat Washer	From Serial or Engine Number 940222
41	3009498X1	1	Hex Cap Screw	M10X55 From Serial or Engine Number 940222
42	339761X1	1	Hex Cap Screw	M8 X 25
43	1440329X1	1	Locknut	M10 From Serial or Engine Number 940222
44	1441858X1	1	Grease Fitting	M6
45	D28283853	15	Hair Pin	
46	354066X1	1	Split Pin	5/32" X 1
47	D28280005	1	Auger	20' - 6,16M Up to Serial or Engine Number 939455
	D28280067	1	Auger	22' - 6,77M Up to Serial or Engine Number 939455
	D28286019	1	Auger	20' - 6,16M From Serial or Engine Number 939649
	D28286021	1	Auger	22' - 6,77M From Serial or Engine Number 939649

Massey Ferguson**MF 7274 / 7278 COMBINES - |---> 61123 / |---> 61115 - 3906105****3906105****Table Auger Left Hand - Freeflow - 20-22'****Page001-0003**

Item	Part Number	Qty	Description	Comments
48	D28280006	1	Auger	20' - 6,16M Up to Serial or Engine Number 939455
48	D28280068	1	Auger	22' - 6,77M Up to Serial or Engine Number 939455
48	D28286018	1	Auger	20' - 6,16M From Serial or Engine Number 939649
48	D28286020	1	Auger	22' - 6,77M From Serial or Engine Number 939649
49	D42329300	1	Roll Of Chain	
50	D20400520	4	Spacer	
51	D20400522	3	Spacer	
52	D42365100	1	Roll Chain Link	
53	D28283294	4	Spike	
54	D28281694	4	Plate	Up to Serial or Engine Number 61489
55	339123X1	20	Hex Cap Screw	M8 X 20
56	D20400506	20	Washer	
57	394367X1	12	Locknut	M8
58	D20400471	2	Washer	
59	D28285967	1	Auger Extension	
60	D28285968	1	Auger Extension	
61	D28285981	2	Bracket	

FOOTNOTE [A] OPTIONAL

MF 7274 / 7278 COMBINES - |---> 61123 / |---> 61115 - 3906105
D-ZAZD-016-B

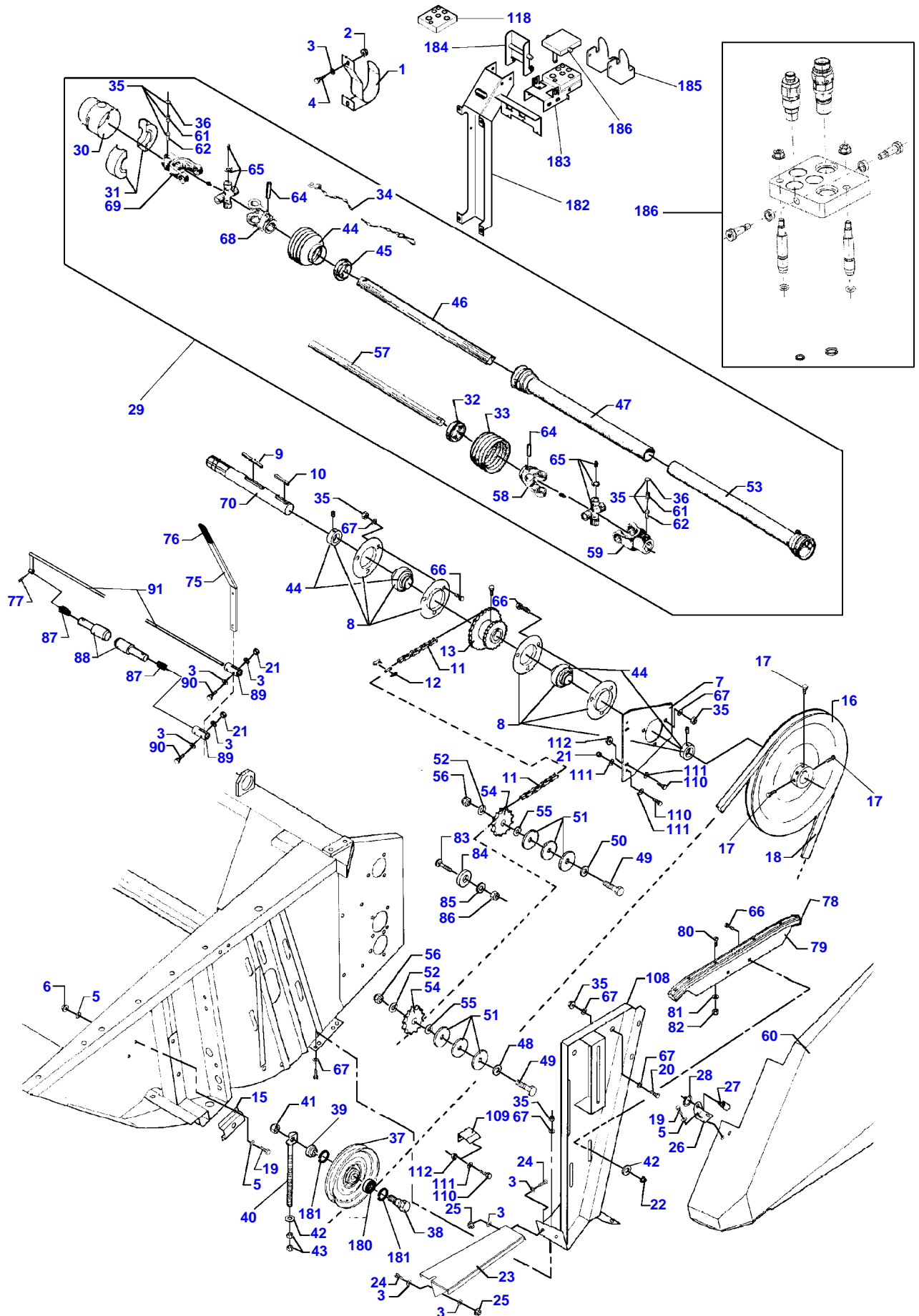

D-ZAZD-016-B

Item	Part Number	Qty	Description	Comments
1	D28281345	1	Stirrup	
2	394367X1	X	Locknut	M8
3	D20400506	X	Washer	
4	339124X1	X	Hex Cap Screw	M8 X 16
5	391038X1	X	Flat Washer	
6	1441462X1	X	Locknut	M6
7	D28285302	1	Bearing Carrier	
8	D41707800	2	Bearing	
9	D43114900	1	Key	
10	1441579X1	1	Key Parallel	
11	D42329300	1	Roll Of Chain	
12	D42365100	1	Roll Chain Link	
13	D28280225	1	Chain Sprocket	
15	D28281578	1	Retainer	
16	D28285423	1	Pulley	
17	D40697900	3	Screw	
18	D41985600	1	Belt	
19	339666X1	X	Hex Cap Screw	M6 X 20
20	3009492X1	4	Hex Cap Screw	M10 X 25
21	394367X1	X	Locknut	M8
22	1440329X1	X	Locknut	M10
23	D28281570	1	Plate	
24	339761X1	3	Hex Cap Screw	M8 X 25
25	394367X1	3	Locknut	M8
26	D28281577	1	Angle.	
27	D43427500	1	Pin	
28	1440988X1	1	Snapping	
29	D45609100	1	Shaft	20' - 6,16M Up to Serial or Engine Number 942481
	D28273974	1	Shaft	20' -6,16M From Serial or Engine Number 942482 WWHU
	D45609300	1	Shaft	22' - 6,77M Up to Serial or Engine Number 942481
	D28273973	1	Shaft	22' - 6,77M From Serial or Engine Number 942482 WWHU
30	D45632900	1	Bush	
31	D45633000	1	Ring	
32	D45630700	1	Ring	
33	D45630500	1	Guard	
34	D45681800	2	Chain	
35	D45632400	2	Tube	
36	D45645700	2	Washer	
37	D28760574	1	Pulley	Valid from machine/table no,can be used in new as well as in older machines 938215
38	D28760156	1	Screw	
39	D28760155	1	Bush	
40	D28260181	1	Bolt	
41	1442739X1	X	Locknut	M16
42	D20400416	X	Washer	
43	339402X1	X	Nut	M10
44	D45630400	1	Guard	
45	D45630600	1	Ring	
46	D45631100	1	Tube	20' - 6,16M
	D45633700	1	Tube	22' - 6,77M
47	D45631900	1	Tube	20' - 6,16M
	D45633900	1	Tube	22' - 6,77M
48	D28181284	1	Washer	
49	391889X1	2	Hex Cap Screw	M16 X 70
50	D20400463	1	Washer	
51	D20400460	6	Washer	
52	D20400459	2	Washer	
53	D45632300	1	Tube	
54	D41716800	2	Tightener	
55	D20400516	X	Spacer	[B]

Item	Part Number	Qty	Description	Comments
56	1442739X1	2	Locknut	M16
57	D45631500	1	Tube	
58	D45630100	1	Yoke	
59	D45633200	1	Yoke	
60	D18281583	1	Guard	
61	D45667300	2	Spring	
62	D45665300	2	Pin	
64	D42619100	2	Pin	
65	D45630300	2	Hub	
66	1442456X1	8	Screw Special	M10 X 30
67	D20400419	X	Washer	
68	D45630200	1	Yoke	
69	D45633100	1	Yoke	
70	D28284404	1	Shaft	
74	D45140037	2	Screw	[A,C]
75	D28285536	1	Lever	
76	D43484900	1	Lever	
77	D42612200	X	Pin	
78	D28280787	1	Rail	
79	D18281365	1	Crossmember	
80	D40609300	6	Screw	
81	D20400466	6	Washer	
82	D41087200	6	Locknut	M4
83	D40073100	1	Screw	
84	D28280981	1	Spacer	
85	D20400459	1	Washer	
86	1442739X1	1	Locknut	M16
87	D27100794	2	Spring	
88	D28283200	1	Shaft	
89	D28285535	2	Fork	
90	339168X1	X	Hex Cap Screw	M8 X 50
91	D28285531	1	Journal	
92	D45140038	2	Ring	[A,C] Up to Serial or Engine Number 59115
108	D18283090	1	Plate	
109	D18283098	1	Union	
110	339123X1	X	Hex Cap Screw	M8 X 20
111	D20400506	X	Washer	
112	394367X1	X	Locknut	M8
118	D28285492	1	Rubber Patch	
180	SKF62042RS	1	Bear. 6204 2rs	Valid from machine/table no.,can be used in new as well as in older machines 938215
181	339199X1	2	Circlip	Valid from machine/table no.,can be used in new as well as in older machines 938215
182	D28285518	1	Bracket	
183	D28285519	1	Support	CPL.
184	D28285497	1	Support	
185	D28285494	1	Stirrup	
186	D45140044	1	Clutch	CPL. See Page - Reference Number 001-0033

FOOTNOTE [A] OPTIONAL EQUIPMENT

FOOTNOTE [B] OPTIONAL

FOOTNOTE [C] NOT ILLUSTRATED

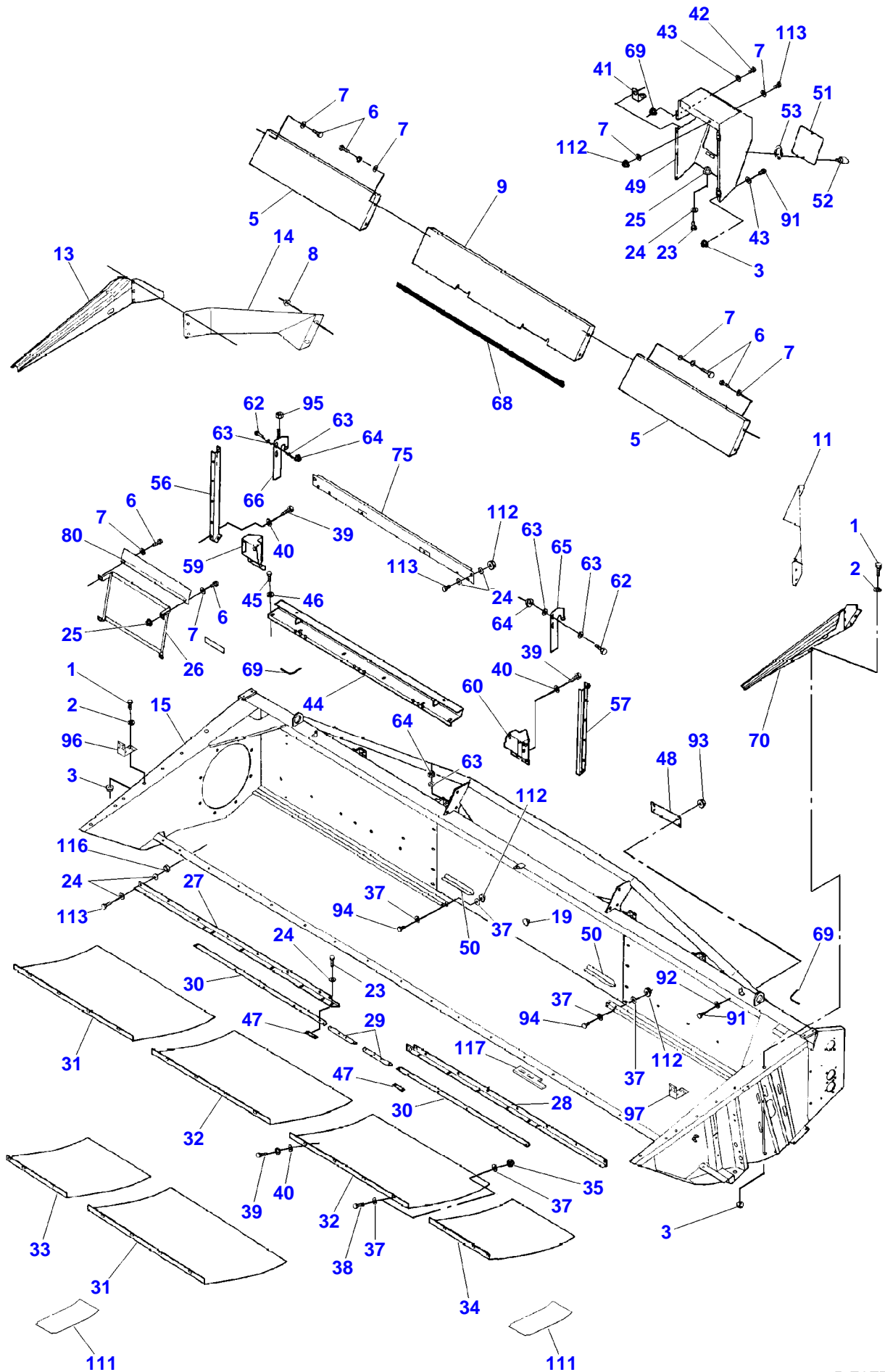

Buy Now



Our support email:

ebooklibonline@outlook.com