

FORD

51, 60 AND 65 RIDER MOWER TRACTOR

OPERATOR'S MANUAL



FORD TRACTOR OPERATIONS

FORD MOTOR COMPANY

Reprinted



Warranty and Limitation of Liability

Ford Tractors and Equipment

COVERAGE PROVIDED

Ford Motor Company and the Selling Dealer jointly warrant to the original purchaser with respect to each Ford Tractor, Ford Implement or piece of Ford Equipment that for the periods specified herein, the Selling Dealer will repair or replace any part that is found to be defective in factory materials or workmanship.

Tractors designated for agricultural use	12 Months
Self-propelled combines and attachments	12 Months
Garden tractors, rider mowers and related attachments	12 Months
Except commercial usage in which case coverage is	90 Days
Tractors and related equipment designated for industrial usage	6 Months
Agricultural implements except self-propelled combines and attachments	6 Months

- The warranty period will begin on the date of original retail delivery or date of original use, whichever is earlier.
- The obligation of Ford and the Selling Dealer under this warranty is limited to repairs or replacements which will be made free of charge for both parts and labor using Ford service parts.
- The repairs or replacements will be performed by the Selling Dealer following delivery of the unit by the customer to the dealer's place of business in the United States.
- If the owner is traveling or has moved a long distance from the Selling Dealer, any authorized Ford Tractor and Equipment Dealer will perform the repairs.
- The Selling Dealer shall review these warranty provisions with his customer, secure his customer's acknowledgement of delivery of this warranty and record the date of original retail delivery.

WHAT IS NOT COVERED BY THE WARRANTY

1. This warranty shall NOT apply to any Ford Tractor, Ford Implement or Ford Equipment:
 - (i) With respect to vendor warranted items such as tires and tubes and attachments, or to batteries which are covered by the Ford Parts and Accessories Warranty.
 - (ii) With respect to vendor warranted items on the Series 340 Compact Loader which includes engine, battery, tires and tubes and attachments.
 - (iii) If it has been subject to misapplication, abuse, misuse, negligence, or fire or other accident, or
 - (iv) If parts not made or supplied by Ford have been used in connection with it if, in the sole judgment of Ford, such use affects its performance, stability or reliability, or
 - (v) If it has been altered or repaired outside of a Ford location in a manner which, in the sole judgment of Ford, affects its performance, stability or reliability.
2. This warranty shall NOT apply to normal maintenance services (such as tune-ups, fuel system cleaning and wheel, brake and clutch adjustments) or to normal replacement of service items (such as filters and brake or clutch linings) or to normal deterioration due to use and exposure (such as belts and exterior finish).
3. This warranty shall NOT apply to any Ford unit which is distributed by anyone other than Ford Tractor and Equipment Operations - North America through its dealers in the United States. This warranty shall NOT apply to any Ford unit which is normally operated outside of the United States.

DISCLAIMER OF IMPLIED WARRANTIES

Except for personal injuries proven to have been caused by a defect, **THIS WARRANTY, to the extent allowed by law, IS EXPRESSLY IN LIEU OF any other express or implied warranty, condition or guarantee agreement or representation by any person with respect to any Ford Tractor, Ford Implement or Ford Equipment or any part thereof, including ANY IMPLIED WARRANTY OF MERCHANTABILITY OR FITNESS.**

- Ford Motor Company and its authorized dealers will not assume any responsibility under this warranty for any loss of use of the unit, loss of time, inconvenience, commercial loss or consequential damages.
- No person is authorized to make any representations beyond those expressed herein.

RIGHT TO MAKE DESIGN CHANGES

Ford Motor Company reserves the right to make changes in the design of and other changes in its products at any time and from time to time without notice and without incurring any obligation with respect to any product previously ordered from it or sold or shipped by it.

SAFETY



WHILE THIS MOWER HAS BEEN BUILT TO OPEI SAFETY STANDARDS, the manufacturer does not mean to imply that this unit is 100% accident proof. **IT MUST BE USED WITH THE SAME CAUTION AND CARE REQUIRED WHEN OPERATING ANY SIMILAR MECHANICAL EQUIPMENT.**



READ THIS MANUAL CAREFULLY BEFORE ACTUAL OPERATION. Assemble your mower completely and carefully as described in this manual. **Do not use mower without either the chute guard or a grass bag.** Keep all safety devices in place and check the grass catcher frequently for signs of wear and deterioration. Replace with new bag as a safety protection.



FAMILIARIZE YOURSELF COMPLETELY WITH ALL CONTROLS AND LEARN TO STOP THE ENGINE IN CASE OF EMERGENCY.

TEACH ALL SAFETY RULES AND OPERATING PROCEDURES TO ALL PERSONS OPERATING MOWER. Never allow children to operate power mower.



ANY CARBURETOR ADJUSTMENTS SHOULD BE MADE WITH EXTREME CAUTION . . .

Mower mufflers develop extreme heat in operation, be careful not to touch the muffler while engine is running . . . or for a while after engine is shut off. Never change engine governor setting



DISENGAGE ALL CLUTCHES AND PUT GEAR-SHIFT IN NEUTRAL BEFORE STARTING ENGINE.

Never run the engine in an enclosed area . . . exhaust fumes are dangerous. Never store the mower with gasoline in the tank, inside a building where fumes may reach an open flame or spark. Allow the engine to cool before storing in any enclosure.



KEEP HANDS AND FEET CLEAR OF MOVING PARTS AND THE DISCHARGE CHUTE . . . AT ALL TIMES!



ALWAYS START MOWER FROM THE SIDE OPPOSITE THE DISCHARGE CHUTE. Have mower on a level surface. When starting "manual start" mowers, stand firmly on the side opposite the discharge chute.



CLEAR THE AREA TO BE MOWED OF ALL STONES, STICKS, WIRE, TIN CANS AND ALL OTHER DEBRIS BEFORE STARTING TO MOW.

Determine the location of and avoid striking any solid, permanent fixtures, such as curbs, tree roots, stumps, water pipes, shut-off valves, etc.



IF YOU SHOULD STRIKE ANY OBJECT:

- **STOP THE MOWER IMMEDIATELY.**
- **DISCONNECT THE SPARK PLUG WIRE FROM SPARK PLUG AND EXAMINE MOWER FOR DAMAGE.**
- **REPAIR OR REPLACE ANY DAMAGED PART BEFORE RESUMING OPERATION.**



DISCONNECT SPARK PLUG WIRE FROM SPARK PLUG AND SECURE THE WIRE AWAY FROM THE SPARK PLUG BEFORE ATTEMPTING ANY ADJUSTMENTS OR REPAIRS. Never attach or remove grass bag, or unclog a chute, while engine is running or blade is turning.



THIS RIDING MOWER IS DESIGNED TO CARRY ONLY THE OPERATOR. In the interest of safety, other passengers, especially children, should never be allowed to ride with the operator.



GIVE COMPLETE AND UNDIVIDED ATTENTION TO THE MOWING JOB. Operate the mower at the slowest speed that will cut the grass satisfactorily. Use caution when operating on uneven terrain. Disengage the blade drive when transporting.



DO NOT WEAR LOOSE CLOTHING THAT MIGHT GET CAUGHT IN MOVING PARTS.



STOP THE ENGINE WHENEVER YOU LEAVE THE MOWER OPERATING POSITION. Never leave the mower running, when you leave it, for any reason. Don't start the mower until you are ready to mow.



DEVELOP THE HABIT OF REMOVING THE KEY EVERY TIME YOU LEAVE THE MACHINE.

KEEP CHILDREN COMPLETELY AWAY FROM THE MOWER WHILE IT IS IN OPERATION. Keep all persons and pets away from area to be mowed. Never direct the discharge of the mower toward bystanders or in a direction where thrown objects could cause injury or damage. Avoid directing discharge toward a street, sidewalk or similar traffic area.



DO NOT DRIVE TOO CLOSE TO A CREEK OR A DITCH AND BE WATCHFUL OF HOLES WHICH MIGHT CAUSE THE RIDER TO TIP SIDEWAYS. Be especially careful when making turns, stopping, starting or backing. Never stop or start suddenly.



BE ESPECIALLY CAREFUL WHEN OPERATING THE RIDER ON HILLSIDES OR SLOPES. As a general rule, if the slope is steep enough to make you feel uncomfortable or uneasy, it is too steep for safe operation of the Rider. Mow up and down the face of a steep slope . . . never across the face.



NEVER OPERATE MOWER IN THE RAIN OR WHEN GRASS IS WET. Slippery conditions are extremely dangerous.



FILL GAS TANK OUTDOORS, BUT NEVER WHILE ENGINE IS RUNNING OR HOT. NEVER FILL TANK WHILE SMOKING. Use an approved container to handle and store an inflammable liquid. If you spill gasoline, wipe it up. Keep mower free from accumulations of grass or debris build-up. Replace gas tank cap securely.

ASSEMBLY

Check the contents of the small carton; it should include:

- Steering Handle
- Chute Deflector
- Seat
- Plastic Fastener Bag

(ELECTRIC START MODELS ONLY)

- Battery Carton (containing Battery and Battery Acid)
- Battery Charger

RIDER EQUIPPED WITH 5 H.P. ENGINE has Battery Carton strapped to left side of frame.

Remove the two "J" bolts holding the front axle and the bolt through the rear hitch, to free the rider from the carton skid.

STEERING HANDLE

Align holes in the Steering Handle with the holes in steering shaft. Secure with two hex head cap screws and lock nuts (included in fastener bag) as shown in FIG. 3.

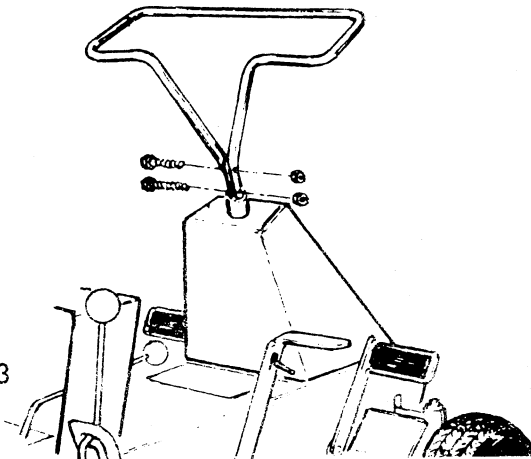

FIG. 3

SEAT ASSEMBLY

Attach the Seat to the Seat Spring using parts from fastener bag as indicated in FIG. 4.

The squareholes in the Seat Spring provide an adjustment to allow the operator to position the seat so that he may easily reach the foot pedals.

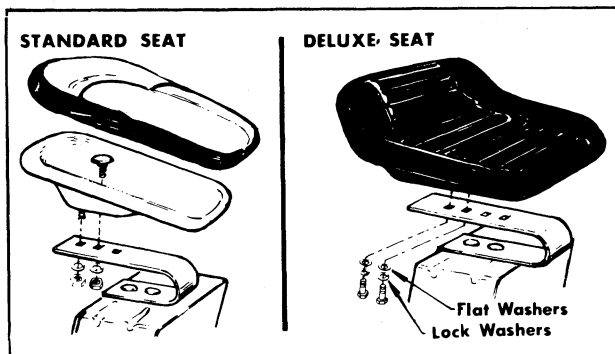

FIG. 4

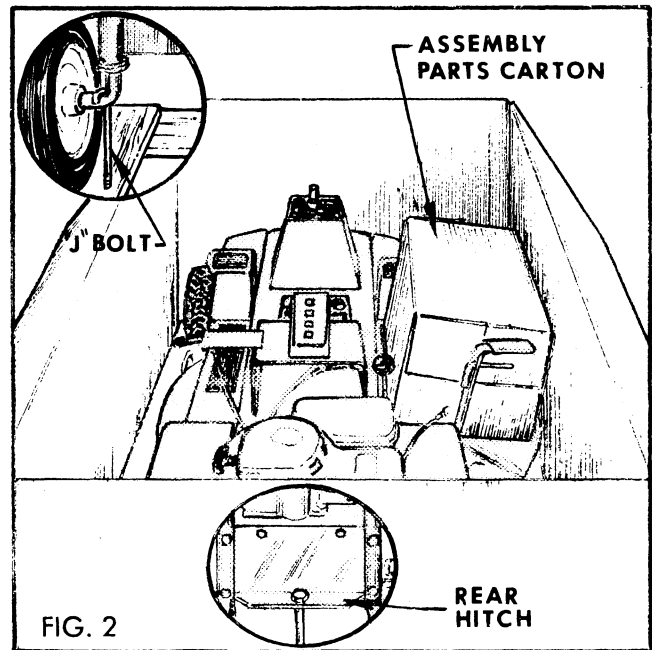

FIG. 2

CHUTE DEFLECTOR

Assemble the Chute Deflector to the Cutter Housing with hex head cap screws and lock nuts (included in fastener bag) as shown in FIG. 5.

WARNING: DO NOT OPERATE THE MOWER WITHOUT THE CHUTE DEFLECTOR OR A GRASS BAG INSTALLED!

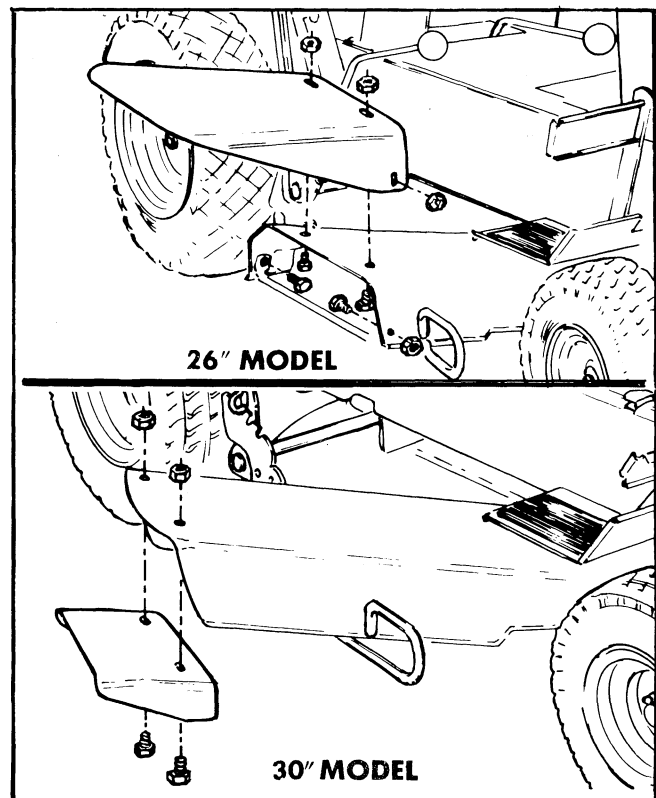

FIG. 5

ASSEMBLY cont.

ELECTRIC START MODEL

Carefully remove the Battery and the Battery Acid from carton. Do not tip or squeeze the Battery Acid carton. Activate the Dry-Charge Battery BEFORE installing it on the rider.

FILL: Carefully fill each cell with acid furnished until it becomes visible at bottom of filling tube. Temperature of acid should be room temperature. Use extreme CAUTION when filling. Should any acid be spilled on your person, your clothing, or the battery during filling—WASH OFF IMMEDIATELY!! and neutralize with soda or ammonia solution.

CHARGING: Loosen or remove the battery filler caps during the charge cycle.

Connect the Battery Charger to the Battery as follows, BEFORE plugging into AC outlet:

- Connect Red POSITIVE (+) Charger Clip to POSITIVE (+) Battery Terminal.
- Connect Black NEGATIVE (–) Charger Clip to NEGATIVE (–) Battery Terminal. (If there is any sparking, the clips are not connected to the proper terminal. . . reverse the connection IMMEDIATELY!
- Make sure all connections are secure.
- Connect the line cord to AC outlet and charge with 1 amp Charger for 24 hours prior to use.

Leave caps off for approximately twenty minutes to allow gases to escape.

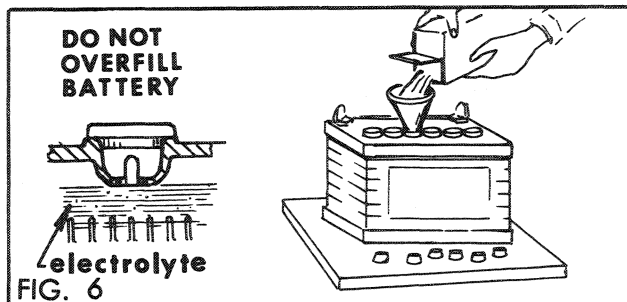

CAUTION: Battery acid is corrosive to metals. Do not pour into any sink or drain. Before discarding, rinse and mutilate electrolyte container.

INSTALLATION:

Position the Battery on the frame and secure with Hold Down Bracket, two Hooks, washers and wing nuts (included in fastener bag) as shown in FIG. 7. Connect wires to Battery as shown, using carriage bolts, lock washers, and hex nuts included in fastener bag.

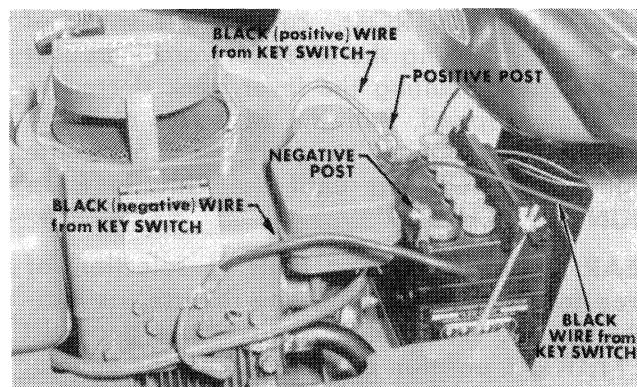

FIG. 7

BEFORE OPERATION

- **READ THIS MANUAL** . . . Become completely familiar with the controls and operation before actual use of the rider.
- **READ** . . . the safety section of this manual.
- **FILL** . . . crankcase with oil.
- **FILL** . . . the fuel tank with clean, fresh "regular" grade gasoline. DO NOT MIX OIL WITH GASOLINE.
- **CHECK** . . . the battery liquid level.
- **CHECK** . . . the oil level of the transaxle.
- **CHECK** . . . the air pressure in the tires. See Specifications

All accessories and attachments have their own manual. Be sure to read such manuals thoroughly for proper assembly and operating instructions.

Thank you so much for reading.
Please click the “Buy Now!”
button below to download the
complete manual.



After you pay.

You can download the most
perfect and complete manual in
the world immediately.

Our support email:

ebooklibonline@outlook.com