

FORD

**42" Mower
Attachment**
Model 09GN3698
For YT 12.5 Yard Tractor

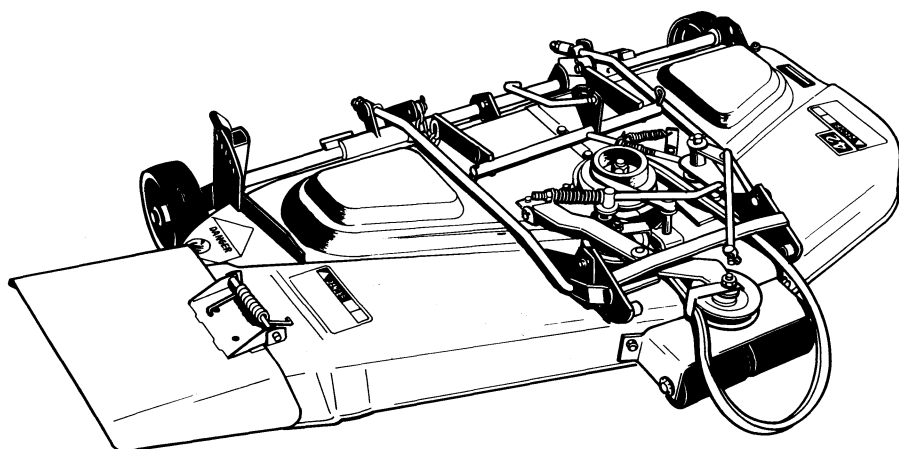

OPERATOR'S MANUAL

42641029

Reprinted

INTRODUCTION

This operator's manual has been prepared to provide the information you need to correctly assemble, operate and maintain your unit. Read it carefully and keep it for future reference. Should you ever need repair parts or service, contact your authorized parts and service dealer.

Be sure safety precautions are observed. Read and follow all safety and operating instructions in this operator's manual.

Any references made in this manual concerning the right- or left-hand sides are determined with the operator facing forward in the operating position.

The replacement of any part on this product by other than the manufacturer's authorized replacement part may adversely affect the performance, durability or safety of this product.

The manufacturer reserves the right to make changes on, or add improvements to its product at any time without prior notice or obligation. The manufacturer also reserves the right to decide, upon its discretion and at any time, to discontinue a product.

NOTICE: Record the model and serial numbers of your unit (located on the nameplate) in the spaces provided below.

Product Model No. _____

Product Serial No. _____

Dealer Purchased From _____

Date Purchased _____

Dealer Address _____

Dealer Telephone No. _____

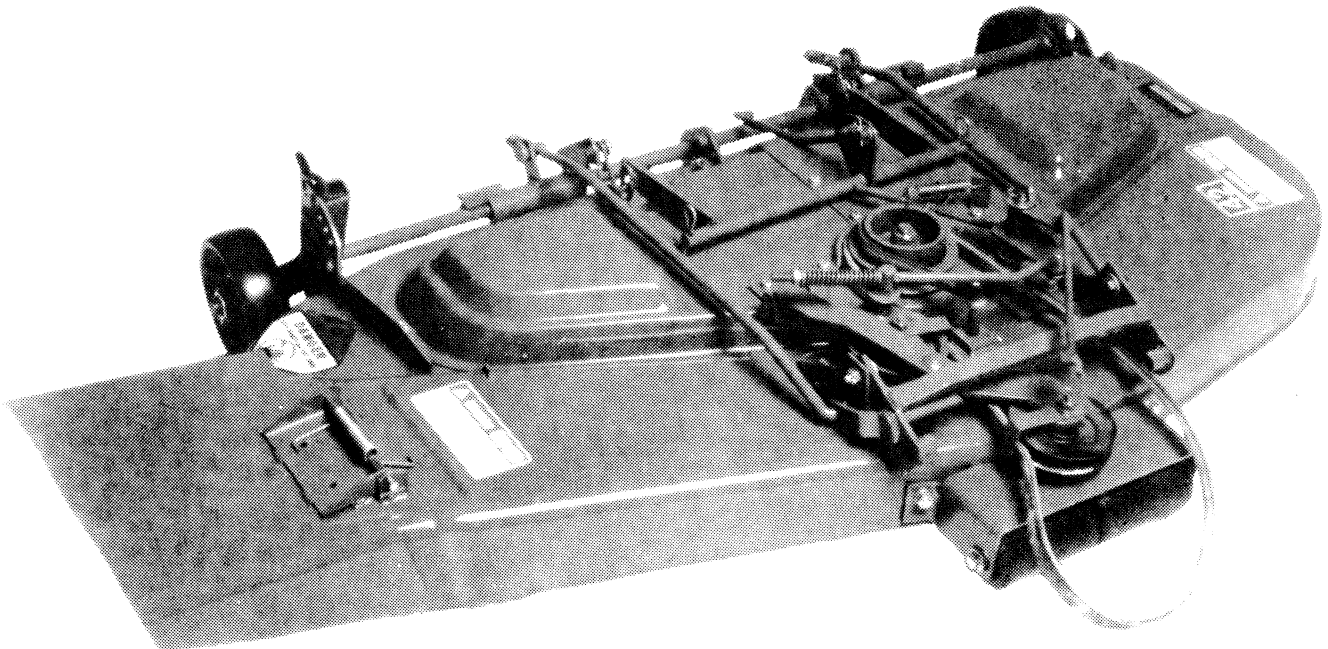

TABLE OF CONTENTS

1 Safety Precautions	1.1-1.2	5 Storage/Trouble Shooting	5.1
2 Controls And Operation		6 Replacement Decals	
Discharge Guard	2.1	Safety	6.1
Controls	2.1	Standard	6.1
Mower Lift	2.1	7 Set-Up And Assembly	7.1-7.5
Cutting Heights	2.1	8 Parts And Parts Lists	8.1-8.4
Cutting Speed	2.1		
Grass Discharge	2.2		
Cutting Patterns	2.2		
3 Maintenance And Lubrication			
Daily Schedule	3.1		
25 Hour Schedule	3.1		
Blade Sharpening	3.2		
Blade Balancing	3.2		
4 Adjustment And Servicing			
Mower Deck Pitch	4.1		
Spindle Bearings	4.1		
Blade Brake	4.1		
Mower Belt	4.2		
Drive Belt	4.3		
Belt Installation Diagram	4.3		

IMPORTANT: IF SAFETY OR STANDARD Decals are missing, illegible, or damaged, they should be replaced. See "Replacement Decals" section.

1 SAFETY PRECAUTIONS

THE FOLLOWING PRECAUTIONS ARE SUGGESTED TO HELP PREVENT ACCIDENTS.

A CAREFUL OPERATOR IS THE BEST OPERATOR. MOST ACCIDENTS CAN BE AVOIDED BY OBSERVING CERTAIN PRECAUTIONS. READ AND TAKE THE FOLLOWING PRECAUTIONS BEFORE OPERATING THIS EQUIPMENT TO HELP PREVENT ACCIDENTS. EQUIPMENT SHOULD BE OPERATED ONLY BY THOSE WHO ARE RESPONSIBLE AND INSTRUCTED TO DO SO.

THE MOWER

- Read this Tractor and Mower operators manual carefully before using the equipment. Lack of operating knowledge can lead to accidents.
- Keep the vehicle and attachments in good operating condition and keep safety devices in place.
- Do not modify or alter or permit anyone else to modify or alter this mower or any of its components or any tractor function.
- Keep people and pets a safe distance away from the machine.
- Clear the work area of objects which might be picked up and thrown.

MOWER OPERATION

- Disengage power to mower when transporting or not in use.
- Disengage power to mower before backing up. Do not mow in reverse unless absolutely necessary and then only after careful observation of the entire area behind the mower.
- When mowing proceed as follows:
 - a) Mow only in daylight or in good artificial light.
 - b) Never make a cutting height adjustment while the engine (motor) is running if the operator must dismount to do so.

- c) Check the blade mounting bolts for proper tightness at frequent intervals.
- d) Shut the engine (motor) off when removing the grass catcher or unclogging chute.

- Watch for holes in terrain and other hidden hazards.
- Do not stop or start suddenly when going uphill or downhill. Mow up and down the face of steep slopes, never across the face.
- Disengage power to attachment(s) and stop the engine (motor) before leaving the operator's position.

SERVICING & MAINTENANCE

- Keep all shields in place.
- Replace safety and warning decals when they become illegible.
- The vehicle and attachments should be stopped and inspected for damage after striking a foreign object and the damage should be repaired before restarting and operating the equipment.
- Do not lubricate or make mechanical adjustments while the unit is in motion or when the engine is running. However, if minor engine adjustments must be made, apply the parking brake securely, block the wheels and use extreme caution.
- Periodically maintain mower. Tighten nuts, bolts and fittings periodically for safe operation. Check blade for tightness.

SAFETY DEFINITIONS

 **DANGER**

The signal word "DANGER" signifies that a source of extreme danger to a person on or near a machine exists as a result of the very nature of the machine itself. This danger to persons is such that it would result in a high likelihood of death or permanent injury if the recommended precautions are not taken.

 **WARNING**

The signal word "WARNING" indicates that a source of danger to a person on or near a machine exists which may result in death or injury if the recommended precautions are not taken.

Whenever you see this symbol



it means: ATTENTION! BECOME ALERT! YOUR SAFETY IS INVOLVED!

SAFETY PRECAUTIONS

Safety is NO accident Be Alert!

This symbol is used to attract your attention to the safety precautions that should be understood by the operator to avoid accidents.



When you see this symbol-HEED ITS WARNING!



- Be sure to read all tractor and engine instructions before operation.
- Know your controls. Know how to stop tractor and engine in an emergency.
- All guards must be in place before operating mower.
- Stop operation when another person approaches.
- Keep children and pets away. Children and pets should be kept a good safe distance away from mower.
- Set parking brake and stop engine before leaving seat.



- Be sure lawn is clean. Remove stones, wires, sticks, toys-anything that might catch or be thrown by the mower blade.

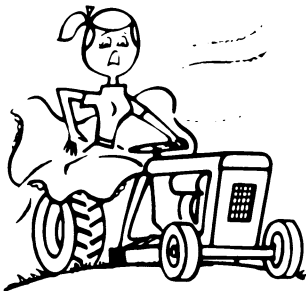

- Do not wear loose fitting clothing that might get caught in moving parts. Also, keep hands and feet away from moving parts.



- Reduce speed on all side slopes and sharp turns to prevent tipping or losing control.

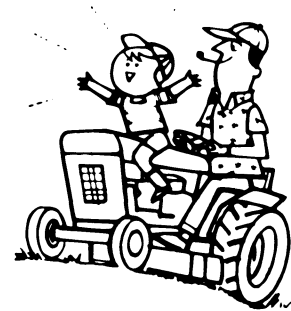

- Do not allow anyone to ride on tractor or any of its attachments.

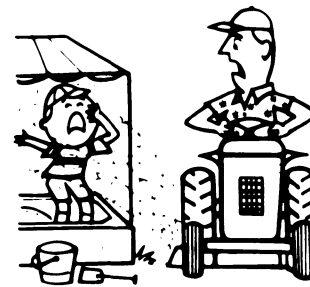

- Never allow tractor to discharge grass toward anyone.
- The discharge guard must be down at all times during mowing operation.

2 CONTROLS AND OPERATION

DISCHARGE GUARD

The discharge guard is assembled to the mower at the factory, ready to use.

WARNING: To avoid personal injury, this guard must be in place and secure when operating mower.

CONTROLS

Review operation of all tractor controls in tractor operator's manual. Power to the mower is controlled by the tractor's P.T.O. The P.T.O. must be OFF unless you are cutting grass.

MOWER LIFT

Lift is controlled by the attachment lift lever or implement lift on your tractor (see your tractor's operator's manual). **NOTE:** On some models of tractors, the attachment lift may not raise the mower gage wheels when cutting height adjustment handle is in high cut position.

WARNING: To avoid personal injury, do not operate mower in the transport position.

CUTTING HEIGHTS

Refer to Fig. 2.1A.

This mower can be adjusted to cut from 1 $\frac{1}{8}$ " to 3 $\frac{5}{8}$ " high. Cutting heights should be determined by cutting conditions and personal preference. The following recommendations will provide a guide for height selection.

LAWNS 1 $\frac{1}{8}$ "-2 $\frac{5}{8}$ "

Due to the size of the mower, it is not recommended that the 1 $\frac{1}{8}$ " cutting height be used on any but the smoothest of lawns.

FIELD CUTTING 2 $\frac{5}{8}$ "-3 $\frac{5}{8}$ "

To change from one cutting height to another slide handle out of notch and move lever to desired notch.

The length of grass being removed should be no more than $\frac{1}{3}$ of the height of the grass before it is cut. Tall grass will have to be cut twice for best results.

CUTTING SPEED

For best mowing results, it is important that blades be run at maximum speed. Set engine speed control in FAST position, thus providing proper blade speed and maximum engine horsepower. Engage the attachment drive

Choose a ground speed which will provide the desired finish cut, will provide maximum operator comfort and will not overload the mower drive. A slower ground speed will provide a smoother operating machine.

WARNING

FAILURE TO FOLLOW SAFE OPERATING PROCEDURE MAY RESULT IN INJURY.

1. READ OPERATOR'S MANUAL
2. KNOW LOCATION AND FUNCTION OF ALL CONTROLS
3. BEFORE LEAVING OPERATOR'S POSITION
 - A. SET PARKING BRAKE
 - B. SHUT ENGINE OFF AND REMOVE KEY
4. WAIT FOR ALL MOVEMENT TO STOP BEFORE SERVICING MACHINE
5. DO NOT OPERATE MACHINE WHERE IT COULD TIP OR SLIP
6. IF MACHINE STOPS GOING UPHILL, DISENGAGE P.T.O. (ATTACHMENT DRIVE) AND BACK SLOWLY DOWN
7. LOOK TO REAR BEFORE BACKING UP
8. REMOVE OBJECTS THAT COULD BE THROWN BY ROTATING BLADES
9. NEVER CARRY CHILDREN. KEEP PEOPLE AND PETS A SAFE DISTANCE AWAY FROM MACHINE
10. KEEP GUARDS AND SAFETY DEVICES IN PLACE AND WORKING

REPLACEMENT MANUALS ARE AVAILABLE FROM YOUR DEALER

TR1059

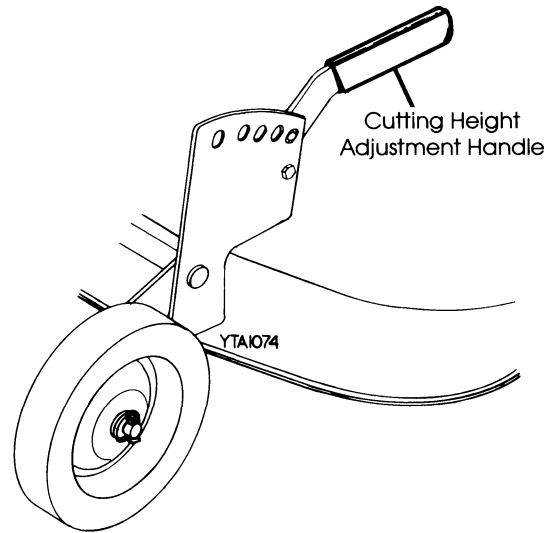

FIG. 2.1A

Thank you so much for reading.
Please click the “Buy Now!”
button below to download the
complete manual.



After you pay.

You can download the most
perfect and complete manual in
the world immediately.

Our support email:

ebooklibonline@outlook.com