

FORD

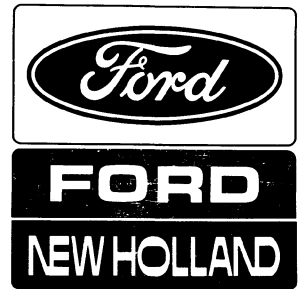

Operator's Manual

40'' Two Stage Snowblower Model 9828130

For YT & LT Series Tractors

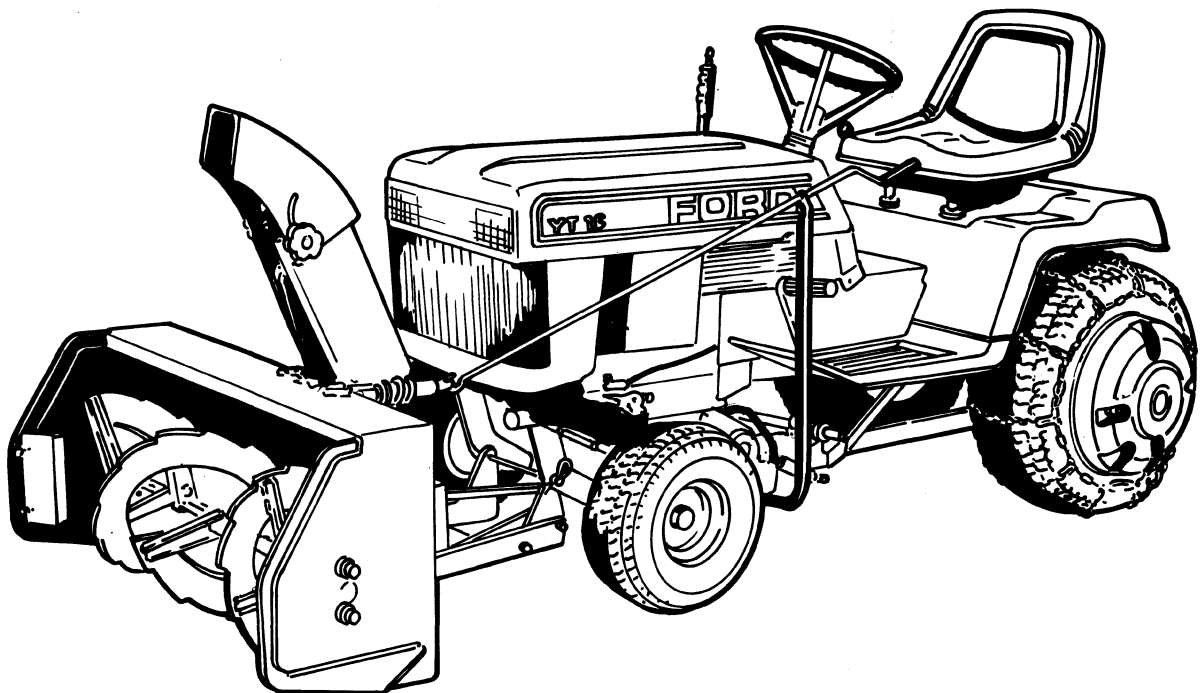

OWNER ASSISTANCE

We at Ford New Holland, Inc. and your Ford New Holland Dealer want you to be completely satisfied with your investment. Normally any problems with your equipment will be handled by your dealer's Service Department. Sometimes however, a misunderstanding can occur. If your problem has not been handled to your satisfaction, we suggest the following:

1. Contact the owner or General Manager of the dealership, explain the problem, and request assistance. When additional assistance is needed, your dealer has direct access to our branch office.
2. If you cannot obtain satisfaction by doing this, contact the Ford New Holland, Inc. branch office in your area and provide them with:
 - o Your name, address and telephone number.
 - o Machine model and serial number.
 - o Your dealership name and address.
 - o The purchase date and amount of use on your equipment.
 - o The nature of problem you are experiencing.

FORD NEW HOLLAND, INC. - Branch Offices**WESTERN U.S.**

San Francisco, California
P.O. Box 6100
Fairfield, CA 94533
Phone: (707)423-9200

SOUTHEASTERN U.S.

Atlanta, Georgia
2000 Mountain Industrial Rd.
Tucker, GA 30084
Phone: (404)723-3615

NORTH CENTRAL U.S.

Minneapolis, Minnesota
P.O. Box 1342
Minneapolis, MN 55440
Phone: (612)887-4232

NORTHEASTERN U.S.

New Holland, Pennsylvania
500 Diller Ave.
New Holland, PA 17557
Phone: (717)355-3951

SOUTH CENTRAL U.S.

Dallas, Texas
P.O.Box 10227
Dallas, TX 75207
Phone: (214)939-4919

WESTERN CANADA

Calgary, Alberta
P.O.Box 1616, Main Post Office
Calgary, Alberta T2P 2M7
Phone: (403)569-3208

EASTERN CANADA

Guelph, Ontario
P.O. Box 3610,
Guelph, Ontario N1H 6P1
Phone: (519)767-4824

IF YOU NEED FURTHER ASSISTANCE, CONTACT:

Consumer Services Department
FORD NEW HOLLAND, INC.
Mail Station 500,
New Holland, PA 17557
Phone: (717) 355-1545

When contacting Ford New Holland Inc.'s Branch Office or Consumer Services department, be aware that your problem will likely be resolved in the dealership, using his facilities, equipment and personnel, so it is important that your initial contact be with your dealer.

TABLE OF CONTENTS

	PAGE
INTRODUCTION	2
SAFETY PRECAUTIONS	3
SAFETY DECALS	5
ASSEMBLY	
Step 1: Subframe Preparation	6
Step 2: Subframe Installation on Tractor	7
Step 3: Snowblower Preparation	8
Step 4: Mounting Snowblower to Tractor	9
DISMOUNTING	11
OPERATING CONTROLS	11
ADJUSTMENTS.....	11
MAINTENANCE	12
PREPARING FOR SNOW REMOVAL	13
SNOW REMOVAL METHODS	14
PARTS LISTS	
Snowblower Head	15
Push Frame	18
Chute and Rotation System	19
Subframe	21
Lift Mechanism	22
Drive Mechanism	23
TORQUE SPECIFICATION TABLE	24

INTRODUCTION

TO THE PURCHASER

This new snowblower was carefully designed to give years of dependable service.

This manual has been provided to assist in the safe operation and service of your snowblower.

NOTE: All photographs and illustrations in the manual may not necessarily depict the actual models or equipment, but are intended for reference only and are based on the latest product information available at the time of publication.

Familiarize yourself fully with the safety recommendations and operating procedures before putting the machine to use. Carefully read, understand and follow these recommendations and insist that they be followed by those who work with you.



THIS SAFETY ALERT SYMBOL IDENTIFIES IMPORTANT SAFETY MESSAGES IN THIS MANUAL. WHEN YOU SEE IT, BE ALERT TO THE POSSIBILITY OF PERSONAL INJURY AND CAREFULLY READ THE MESSAGE THAT FOLLOWS.

Record your snowblower model and serial number. Your **FORD NEW HOLLAND** Dealer requires this information to give you prompt, efficient service when ordering parts or attachments. Service with genuine **FORD NEW HOLLAND** parts when replacement parts are required.

If warranty repairs are required please present this registration booklet and original sales invoice to your selling dealer for warranty service.

Right hand and left hand are determined by sitting on tractor seat facing forward.

MODEL: 9828130 **SERIAL NUMBER:** _____ **DATE PURCHASED:** _____

THE SERIAL NUMBER PLATE (BELOW) IS LOCATED ON THE RIGHT HAND SIDE OF THE IMPELLER HOUSING. IT IS RIVETED ON AND SHOULD NOT BE REMOVED.

FORD NEW HOLLAND INC. NEW HOLLAND, PENNSYLVANIA	
	MODEL NO.
FORD	SERIAL NO.
NEWHOLLAND	COMPONENT
MADE IN CANADA	

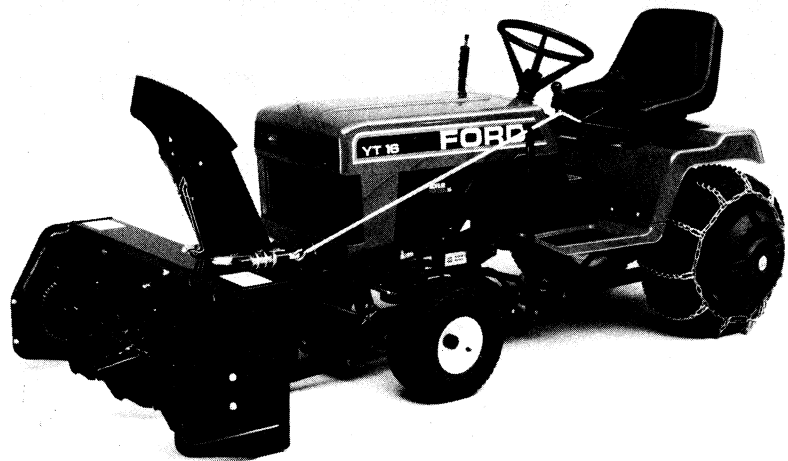

Careful operation is your best insurance against an accident. Read this section carefully before operating the tractor and attachment. All operators, no matter how experienced they may be, should read this and other related manuals before operating the attachment. It is the owner's legal obligation to instruct all operators in safe operation.

WHENEVER YOU SEE THIS SYMBOL 

IT MEANS:

ATTENTION!

BECOME ALERT!

YOUR SAFETY IS INVOLVED!



The signal word "DANGER" signifies that a source of extreme danger to a person on or near a machine exists as a result of the very nature of the machine itself. This danger to persons is such that it would result in a high likelihood of death or permanent injury if the recommended precautions are not taken.



The signal word "WARNING" indicates that a source of danger to a person on or near a machine exists which may result in death or injury if the recommended precautions are not taken.

BEFORE OPERATION

 This symbol, the industry's "Safety Alert Symbol", is used throughout this manual and on snowblower safety labels to warn of the possibility of personal injury. Your dealer requests that you take special care in understanding the safety precautions before operating snowblower and the tractor.

1. Read and understand this Operator's Manual and the tractor Operator's Manual. Know how to operate all controls and how to stop the unit and disengage the controls quickly.
2. Never allow other persons to operate the equipment without proper instruction. Never allow children to operate the equipment.
3. Keep the area of operation clear of all bystanders, especially small children and pets.
4. Never wear loose, torn, or bulky clothing around the tractor and attachment. It may catch on moving parts or controls, leading to the risk of accident.
5. Before the snow season, thoroughly inspect the area where the equipment is to be used and remove all door mats, sleds, boards and other foreign objects.
6. Disengage clutch and shift into neutral before starting the engine.
7. Do not operate equipment in winter time without wearing adequate winter garments.
8. Never attempt to make any adjustments while engine is running.

SAFETY PRECAUTIONS

SNOWBLOWER OPERATION

NOTE: POWER TAKE OFF is abbreviated to PTO, which is the power source for the snowblower and is activated by manual or electric clutch.

1. Make sure drive belt is routed properly before operation.
2. Before getting off tractor, take all possible precautions. Disengage PTO, lower the attachment, shift into neutral, set the parking brake, stop the engine and remove the key.
3. Before starting, remove any ice that has accumulated in the auger/impeller.
4. Watch carefully for foreign objects that could enter the blower while operating.
5. Be sure the PTO switch/lever is in **OFF** position before starting engine.
6. Do not put hands or feet near rotation parts. Keep clear of discharge opening at all times.
7. Exercise extreme caution when operating on or crossing a gravel drive, walks, or roads. Stay alert for hidden hazards of traffic. Do not carry passengers.
8. Adjust collector housing height to clear gravel or crushed rock surface.
9. Use adequate safety warning lights. Check local regulations.
10. Stop the engine, remove the key, set the parking brake, and allow the rotating parts to stop before unclogging the collector/impeller housing or chute, and before making any repairs, adjustments or inspections. Use only a 36" long piece of wood to unclog blower.
11. If the snowblower starts to vibrate abnormally, stop the engine immediately and check for cause. Excessive vibration is generally a sign of trouble.
12. Do not run the engine indoors except when starting engine and transporting attachment in or out of building. Carbon monoxide gas is colorless, odorless and deadly.
13. Exercise extreme caution when changing direction on slopes. Do not attempt to clear steep slopes.
14. Never operate snowblower without guards, and other safety protective devices in place.
15. Never operate snowblower near glass enclosures, automobiles, window wells, embankments, etc., without proper adjustment of snow discharge angle.
16. Never operate machine at high transport speeds on a slippery surface.
17. Use extra caution when backing up.
18. Do not direct discharge at bystanders or animals. Ejected objects may cause injury.
19. Disengage power to auger/impeller when transporting or when not in use.
20. Never operate the snowblower without good visibility and lighting.
21. Use only Ford New Holland approved tire chains and counterweights for better traction and stability (see **WARNING** on page 10).
22. Prolonged exposure to loud noise can cause impairment or loss of hearing. Wear a suitable hearing protective device such as earmuffs or earplugs to protect against objectionable or uncomfortable noises.

REPLACE IMMEDIATELY IF DAMAGED

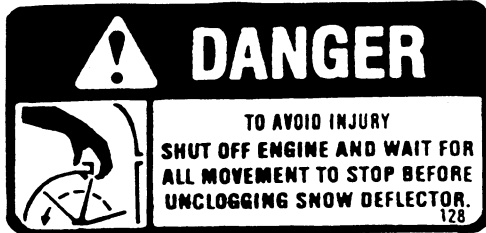

1. BER 657723



2. BER 657725

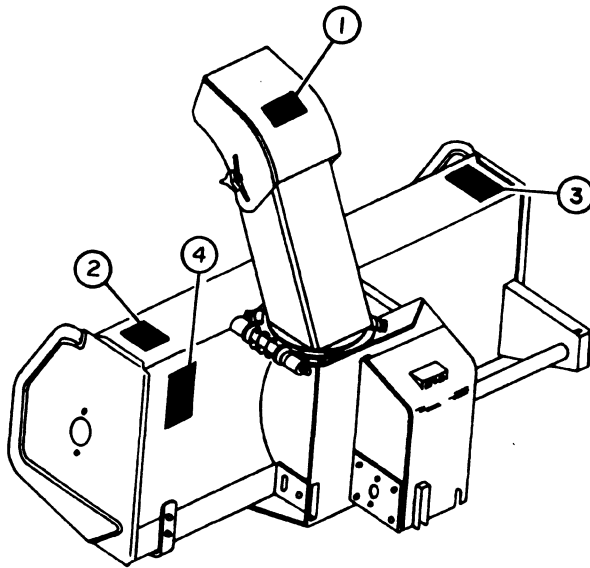

3. BER 657724



4. BER 660265

Thank you so much for reading.
Please click the “Buy Now!”
button below to download the
complete manual.



After you pay.

You can download the most
perfect and complete manual in
the world immediately.

Our support email:

ebooklibonline@outlook.com