

Magnum 235

Magnum 260

Magnum 290

Magnum 315

Magnum 340

Magnum 370

Tractor

PIN ZDRD06500 and above

OPERATOR'S MANUAL

Part number 47596118

1st edition English

September 2013



Contents

1 GENERAL INFORMATION

Note to the owner.....	1-1
Engine tampering.....	1-1
Tractor intended use.....	1-1
Electro-magnetic compatibility (EMC).....	1-2
Product identification.....	1-3
Manual storage.....	1-6
Machine orientation.....	1-7
Component identification.....	1-8

2 SAFETY INFORMATION

Safety rules.....	2-1
Safety rules - General.....	2-2
Safety rules - General maintenance safety.....	2-4
Safety rules - Wheels and tires.....	2-4
Safety rules - Driving on public roads and general transportation safety.....	2-4
Safety rules - Fire and explosion prevention.....	2-5
Safety rules - General battery safety.....	2-5
Safety rules - Instructional seat safety.....	2-6
Safety rules - Operator presence system.....	2-6
Safety rules - Power Take-Off (PTO).....	2-6
Safety rules - Reflectors and warning lights.....	2-6
Safety rules - Seat belts.....	2-6
Safety rules - Roll Over Protective Structure (ROPS).....	2-7
Safety rules - Cab protection.....	2-8
Safety rules - Air conditioning system.....	2-8
Safety rules - Personal Protective Equipment (PPE).....	2-8
Safety rules - Do Not Operate tag.....	2-9
Safety rules - Hazardous chemicals.....	2-9
Safety rules - Utility safety.....	2-9
Safety rules - Electrical storm safety.....	2-9
Safety rules - Mounting and dismounting.....	2-10
Safety rules - Working at heights.....	2-10
Safety rules - Lifting and overhead loads.....	2-10
Safety rules - Implements, tools and trailers.....	2-11
Safety rules - Roll over and tip over.....	2-11
Ecology and the environment.....	2-13
Safety signs.....	2-14
Safety aspects.....	2-27
Fire extinguisher.....	2-34
Emergency exit.....	2-35
Wheel wedges.....	2-36

3 CONTROLS/INSTRUMENTS

ACCESS TO OPERATOR'S PLATFORM

Cab - Access/Exit.....	3-1
Lower step.....	3-2

OPERATOR'S SEAT

Overview.....	3-3
Control identification.....	3-4

INSTRUCTOR'S SEAT

Instructional seat.....	3-7
-------------------------	-----

FORWARD CONTROLS

Steering column.....	3-8
Front console.....	3-11
Pedal controls.....	3-13

LEFT-HAND SIDE CONTROLS

Emergency brake lever.....	3-15
----------------------------	------

RIGHT-HAND SIDE CONTROLS

Armrest console.....	3-16
Multi function handle.....	3-17
Minimum/maximum RPM throttles.....	3-22
Control panel.....	3-24
Remote valve controls.....	3-33
Joystick.....	3-34
Armrest compartment.....	3-36
Adjusting the armrest console.....	3-38

REARWARD CONTROLS

Fender console.....	3-39
Automatic temperature controls.....	3-42
Automatic temperature control system.....	3-45
Ventilation.....	3-46

OVERHEAD CONTROLS

Interior lamps.....	3-48
---------------------	------

EXTERIOR CONTROLS

Rear fender.....	3-49
Front hitch.....	3-50

INSTRUMENT CLUSTER

Overview.....	3-51
Gauges.....	3-52

Status and warning icons	3-53
Upper display	3-56
Lower display	3-59
Keypad	3-61
Setup menu	3-63
Rear tire radius chart	3-69
Adjust menu	3-70
Performance instrumentation	3-77

4 OPERATING INSTRUCTIONS

COMMISSIONING THE UNIT

Before starting the engine	4-1
----------------------------------	-----

STARTING THE UNIT

Normal engine starting	4-4
Cold starting aids	4-8
Cold temperature operation	4-10

STOPPING THE UNIT

Stopping the engine	4-12
---------------------------	------

MOVING THE UNIT

FULL POWERSHIFT TRANSMISSION	4-14
Powershift transmission	4-14
Best practices for prolonged transmission life	4-15
Inching pedal and throttle	4-16
Powershift transmission controls	4-17
Upper display - Powershift transmission	4-20
Driving the Powershift vehicle	4-22
Setting default gears	4-27
Automatic Productivity Management (APM)	4-29
CONTINUOUSLY VARIABLE TRANSMISSION (CVT)	4-36
CVX brake, pedal and throttle operation	4-36
CVX controls	4-41
Upper display	4-46
CVX operation	4-47
Driving the Continuously Variable Transmission (CVT)	4-50
Auto calibration, if equipped	4-55
Transmission messages	4-57
POWERSHIFT AND CVT TRANSMISSIONS	4-59
Mechanical Front Drive (MFD)	4-59
Differential lock system	4-63
Suspended axle	4-66
Ride control	4-73
Suspended cab	4-75
Constant engine speed	4-76
Engine power boost	4-79

Electronic end of row system.....	4-80
-----------------------------------	------

PARKING THE UNIT

Automatic park lock.....	4-86
--------------------------	------

5 TRANSPORT OPERATIONS

ROAD TRANSPORT

Tractor warning lamps.....	5-1
Safe transport speed.....	5-3

SHIPPING TRANSPORT

Securing the tractor for shipping.....	5-4
--	-----

RECOVERY TRANSPORT

Safety rules.....	5-5
Towing the tractor.....	5-6

6 WORKING OPERATIONS

GENERAL INFORMATION

Overview.....	6-1
---------------	-----

REAR POWER TAKE-OFF (PTO)

Safety rules.....	6-2
Connecting the Power Take-Off (PTO).....	6-6
Interchangeable Power Take-Off (PTO) shaft.....	6-7
Rear Power Take-Off (PTO) operation.....	6-13
Power Take-Off (PTO) fender switch operation.....	6-17
Auto Power Take-Off (PTO) operation.....	6-18

FRONT POWER TAKE-OFF (PTO)

Overview.....	6-21
Front Power Take-Off (PTO) operation.....	6-22

REAR HITCH

Identification.....	6-25
Link adjustment.....	6-26
Hitch high clearance adjustment.....	6-30
Hydraulic links.....	6-33
Sway limiter adjustment.....	6-35
Automatic telescoping stabilizers.....	6-36
Lower link block adjustment.....	6-38
Mechanical float adjustment.....	6-40

Hitch operation	6-41
Hitch remote switch operation	6-46
Position control operation	6-48
Load control operation	6-50
Slip control operation	6-52
Hitch set point	6-54

FRONT HITCH

Overview	6-56
Front hitch operation	6-57

DRAWBARS AND TOWING ATTACHMENTS

Safety rules	6-64
Drawbar capacity/position	6-64
Adjusting the drawbar	6-67

TRAILER HITCHES

Clevis and special drawbars	6-69
Automatic trailer hitch	6-71
Auto pickup hitch operation	6-74
Manual trailer hitch	6-76

AUXILIARY CONNECTIONS

Auxiliary power and lighting	6-78
Cab power connections	6-80
Radar connection	6-82

HYDRAULIC REMOTE CONTROL VALVES

Valve couplers and connections	6-83
Motor return circuit	6-86
Power beyond circuit	6-87
Flow capacity	6-88
Hydraulic transport lock	6-89
Operating the controls	6-90
Remote valve display screens	6-94
Remote hydraulic auto mode	6-98
Auto depth control	6-100
Joystick operation	6-102

BALLASTING THE TRACTOR

Guidelines	6-105
Tire load and inflation charts	6-114
Weights, cast metal	6-116
Wheel slip and power hop performance	6-125

MECHANICAL FRONT DRIVE (MFD) AXLES

Tire combinations and tread positions	6-128
---	-------

Steering and oscillation stops	6-133
Tread and fender settings - Case IH 4.75 and 5.0 fixed front axles	6-135
Tread and fender settings - Case IH 4.75 and 5.0 saddle suspended front axles	6-138
Front fenders - Case IH front axles - Wide fenders, fixed or saddle suspended	6-141

REAR AXLE

Rear wheel installation	6-146
Rear wheel tread settings	6-148

7 MAINTENANCE

GENERAL INFORMATION

Safety rules	7-1
Maintenance guidelines	7-1
Opening the hood	7-3
Closing the hood	7-4
Filling the fuel tank	7-5
Battery access and service	7-6
Tire and rim service	7-8
Tractor jacking points	7-10
Capacities	7-12
Consumables - Engine oil	7-14
Consumables - Transmission/hydraulic system fluid	7-15
Consumables - Diesel fuel	7-16
Consumables - Coolant solutions	7-17
Consumables - Coolant solution for Tier 4b engines	7-18
Electrical component location	7-19
Lamps and bulbs	7-24
Maintenance chart notes	7-25

MAINTENANCE CHART

Maintenance Chart	7-26
-------------------------	------

At warning message display

Air filter service icon/message	7-28
Fuel filter water separator	7-29
Hydraulic oil filter switch	7-30
Transmission oil filter switch	7-33

First 10 to 50 hours

Differential and planetary oil	7-36
Wheel bolt torque	7-37
Weight bolt torque	7-37

Every 10 hours or daily

Engine oil level	7-38
Transmission oil level	7-39

Engine coolant level	7-40
Engine auxiliary fuel filter	7-41
Air reservoir	7-42
Rear hitch and front axle	7-42

Every 50 hours or weekly

Engine primary fuel filter	7-43
----------------------------------	------

Every 100 hours

Front hitch	7-44
Front Power Take-Off (PTO) drive shaft	7-46

Every 300 hours

Battery water level (Note E)	7-47
Engine air intake hoses	7-49
Engine coolant level - deaeration tank	7-51
Wheel bolt torque	7-52
Weight bolt torque	7-52
Front axle (Note A)	7-53
Rear hitch (Note A)	7-55
Fuel tank	7-57
Differential and planetary oil level (Note B)	7-58
Transmission oil pressure	7-59
Front Power Take-Off (PTO) oil level	7-60

Every 400 hours

Cab air filter	7-61
----------------------	------

Every 600 hours

Engine oil and filter	7-64
Engine coolant antifreeze protection	7-67
Engine coolant hoses and clamps	7-67
Engine primary fuel filter	7-69
Engine fuel pre-filter	7-72
Fuel system bleeding	7-74
Changeable Power Take-Off (PTO) internal splines	7-75
Front Power Take-Off (PTO) oil and filter	7-76

Every 1000 hours or annually

Pneumatic brake system dryer	7-78
------------------------------------	------

Every 1200 hours or annually

Differential and planetary oil	7-79
Engine air filters	7-83
Engine air precleaner	7-87

Every 1500 hours

Transmission oil	7-89
Hydraulic oil filter	7-92
Transmission oil filter	7-93
Engine crankcase filter	7-94

Every 2000 hours

Engine coolant.....	7-98
---------------------	------

Every 3000 hours

Engine valve adjustment (Note C).....	7-100
---------------------------------------	-------

As required

Vehicle fire prevention	7-101
Cab air filter.....	7-102
Engine primary air filter.....	7-105
Grille screen and radiator area	7-108
Fuel tank vent filter	7-110
Transmission clutch and accumulator	7-111
Tire pressure	7-112
Fan belt.....	7-113
Remote valve collection bottle.....	7-119
Engine auxiliary fuel filter.....	7-120
Cab fabric and carpet.....	7-122
Seat belt	7-123

STORAGE

Preparing for storage	7-124
Removing from storage.....	7-125

ELECTRICAL SYSTEM

Radio or audio system.....	7-126
Battery removal and installation	7-127
Auxiliary battery connections	7-129
Headlight	7-130
Fender tail light and warning light	7-133
Roof front warning and work light	7-135
Rear roof warning light	7-138
Rotating beacon light	7-140
Interior light.....	7-141

8 TROUBLESHOOTING

FAULT CODE RESOLUTION

Display warnings overview	8-1
---------------------------------	-----

Display warnings - Level 1	8-2
Display warnings - Level 2	8-5
Display warnings - Level 3	8-8
Display warnings - Level 4	8-10

SYMPTOM(S)

Engine symptoms	8-12
Transmission symptoms.....	8-14
Hydraulic symptoms	8-15
Hitch symptoms	8-16
Brake symptoms.....	8-17
Cab environment symptoms.....	8-18
Electrical power system symptoms.....	8-19

9 SPECIFICATIONS

Engine specifications	9-1
Power train specifications	9-2
Operating speeds.....	9-5
Vehicle dimensions and shipping weight	9-12
Maximum operating weight.....	9-17

10 ACCESSORIES

Farming system displays	10-1
Chemical tank mounting.....	10-2
Loader connection and operation	10-4
Trailer brake connections.....	10-5
General accessories.....	10-8

1 - GENERAL INFORMATION

Note to the owner

This manual contains important information about the safe operation, adjustment and routine maintenance of your Magnum series tractor. The manual is divided into 10 chapters as outlined in the table of contents. Refer to the index at the end of this manual for locating specific items about your tractor.

Do NOT operate or permit anyone to operate or service this machine until you or the other persons have read this manual. Use only trained operators who have demonstrated the ability to operate and service this machine correctly and safely.

This Operator's Manual is to be stored in the manual compartment behind the operator's seat in the vehicle. Make sure this manual is in good condition. Contact your dealer to obtain additional manuals.

Your CASE IH dealer will instruct you in the general operation of your new equipment. Your dealer's staff of factory-trained service technicians will be glad to answer any questions that may arise regarding the operation of your machine. They will also provide any after-sales service you may need, and genuine CASE IH parts, your guarantee of quality and match.

Engine tampering

The fuel system and engine on your machine are designed and built to government emissions standards. Tampering by dealers, customers, operators, and users is strictly prohibited by law.

Failure to comply could result in government fines, rework charges, invalid warranty, legal action, and possible confiscation of the machine until rework to original condition is completed. Engine service and/or repairs must be done by a certified technician only!

Tractor intended use

Magnum series tractors with standard equipment and authorized attachments, are intended to be used for customary farming, land leveling and related agriculture operations (intended use). Installation of utility (dozer) blades, tile plows, or push bars on the tractor is not recommended. Any tractor damage resulting from the installation and/or use of such equipment is not covered by the tractor warranty.

The tractor is not designed for light/heavy forestry applications; usage is prohibited for forestry applications.

Do not use this machine for any purpose or in any manner other than as described in the manual, decals, or other product safety information provided with the machine. These materials define the machine's intended use.

Consult an authorized dealer or CNH America LLC on changes, additions or modifications that can be required for this machine to comply with various regulations and safety requirements. Unauthorized modifications will cause serious injury or death. Anyone making such unauthorized modifications is responsible for the consequences.

Use in any other way is considered as contrary to the intended use. The manufacture accepts no liability for any damage or injury resulting from this misuse and these risks must be born solely by the user.

Electro-magnetic compatibility (EMC)

Interference may arise as a result of add-on equipment that may not necessarily meet the required standards. As such interference can result in serious malfunction of the unit and/or create unsafe situations, you must observe the following:



- The maximum power of emission equipment (radio, telephones, etc.) must not exceed the limits imposed by the national authorities of the country where you use the machine
- The electro-magnetic field generated by the add-on system should not exceed **24 V/m** at any time and at any location in the proximity of electronic components
- The add-on equipment must not interfere with the functioning of the on board electronics

Failure to comply with these rules will render the CASE IH warranty null and void.

Product identification

Tractor model and product identification number

Write your model number, product identification number (PIN) or serial number of major components on the lines provided. If needed, give these numbers to your dealer when you need parts or information for your machine.

		CNH America LLC Racine, WI 53404 U.S.A. Made In U.S.A.			
Type 1	EEC Number 2	Product Identification Number 3			
• Total Permissible Mass (*): 4 kg		Permissible Towable Mass:			
• Permissible Front Axle Load (*): 5 kg		• Unbraked Towable Mass: 7 kg		• Independently-Braked Towable Mass: 8 kg	
• Permissible Rear Axle Load (*): 6 kg (* Depending on the Tires)		• Inertia-Braked Towable Mass: 9 kg		• Towable Mass Fitted with an Assisted Braking System: (Hydraulic or Pneumatic): 10 kg	

RCIL11CCH007EAA 1

1. Type	Permissible towable mass:
2. EEC number	• 7. Unbraked towable mass
3. Product identification number	• 8. Independently brakes towable mass
4. Total permissible mass	• 9. Inertia braked towable mass
5. Permissible front axle load	• 10. Towable mass fitted with an assisted braking system (hydraulic or pneumatic)
6. Permissible rear axle load	

Model :

PIN:

NOTE: Located on right hand front casting. Pin plate may be mounted vertically or horizontally.

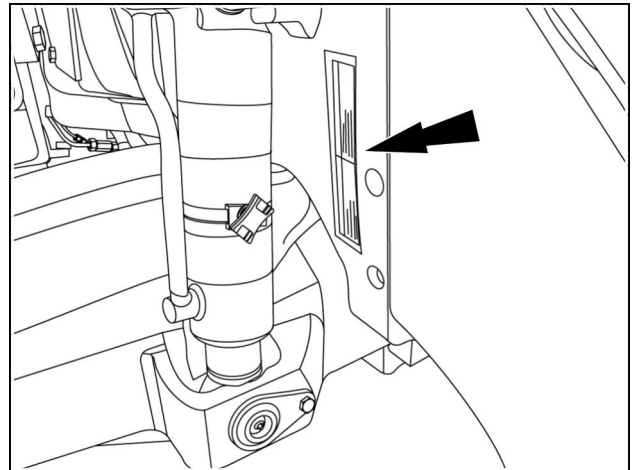

RCPH11CCH013BAB 2

Roll Over Protective System (ROPS) serial number

NOTE: Located on the right hand cab floor.

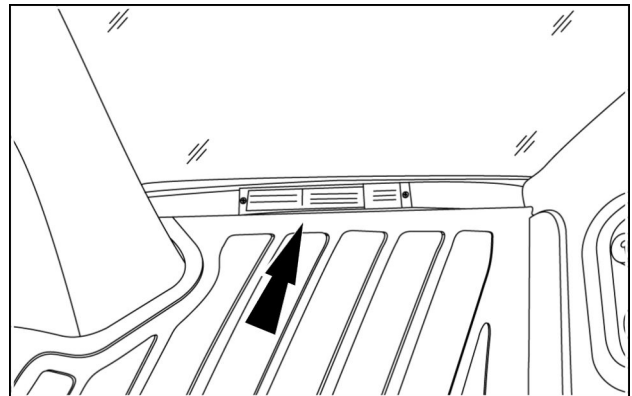

RCPH11CCH014AAB 3

Engine serial number

NOTE: Located on the valve cover. The serial number is also etched into the left hand side of the engine block, just below the oil cooler.

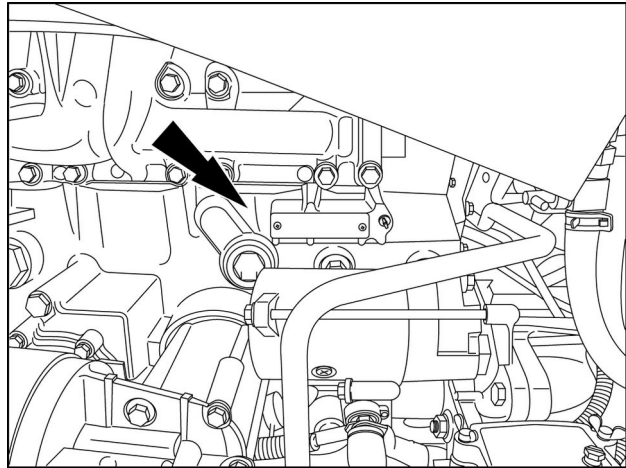

RAIL12TR02140AA 4

Transmission serial number

NOTE: Located on the right hand side of the transmission to the left of the main hydraulic filter

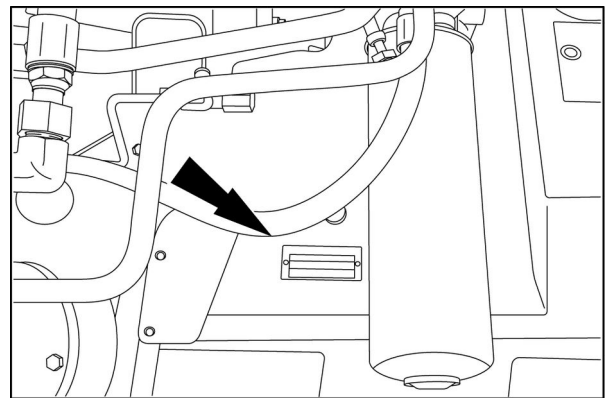

RAIL12TR01410AA 5

Powershift transmission

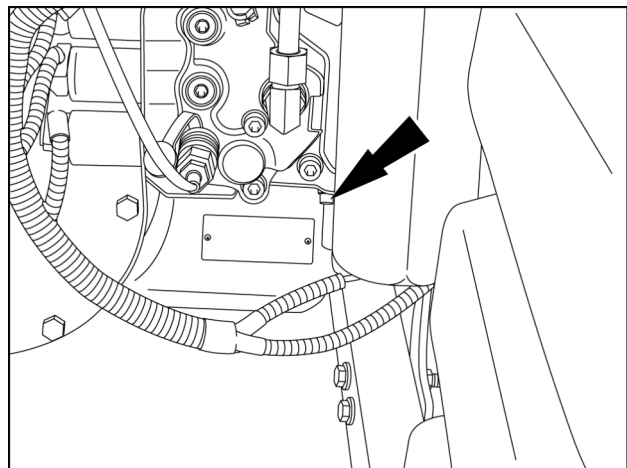

RAIL12TR02191AA 6

CVX transmission

Buy Now



Our support email:

ebooklibonline@outlook.com