

ORIGINAL INSTRUCTIONS

OPERATOR'S MANUAL

T9.435

T9.480

T9.530

T9.565

T9.600

T9.645

T9.700

Tier 4B (final)

Tractor

PIN ZFF403001 and above

Part number 47754862

1st edition English

July 2015



Contents

1 GENERAL INFORMATION

Note to the owner.....	1-1
Intended use.....	1-1
CNH Industrial America LLC technical manuals	1-2
Your tractor	1-3
Electro-Magnetic Compatibility (EMC)	1-4
Product identification	1-5
Operator's manual storage on the machine	1-8
Machine orientation.....	1-9
Component location	1-11
Selective Catalytic Reduction (SCR) system.....	1-13

2 SAFETY INFORMATION

Safety alert symbol and signal word definition	2-1
Proposition 65	2-2
Safety rules.....	2-3
Ecology and the environment	2-14
Protective structures.....	2-15
Emergency exit	2-16
Articulation cylinder locking blocks	2-17
Safety signs	2-18

3 CONTROLS AND INSTRUMENTS

Access to operator's platform

Cab access/exit.....	3-1
----------------------	-----

OPERATOR'S SEAT

Overview	3-3
Control identification.....	3-4

INSTRUCTOR'S SEAT

Overview	3-7
----------------	-----

FORWARD CONTROLS

Steering column controls	3-9
Front console controls.....	3-12
Pedal controls	3-13
Ventilation	3-15
Front sun shade	3-16

RIGHT-HAND SIDE CONTROLS

Armrest console	3-17
Multi-function handle	3-18
Throttle control	3-22
Control panel	3-23

Remote valve controls	3-29
Joystick	3-30
Armrest compartment	3-31
Hitch controls	3-33
Adjusting the armrest console	3-34

REARWARD CONTROLS

Rear sun shade	3-35
----------------------	------

OVERHEAD CONTROLS

Overview	3-36
Automatic Temperature Control (ATC)	3-38
Automatic Temperature Control (ATC) operation	3-42
Center panel controls	3-44
Radio (if equipped)	3-48
Interior and access lights	3-49
Interior rear-view mirror	3-50

EXTERIOR CONTROLS

Exterior hitch control	3-51
Outside extendable mirrors	3-51

INSTRUMENT CLUSTER

Overview	3-52
Gauges	3-52
Status and warning icons	3-53
Upper display	3-56
Diesel Exhaust Fluid (DEF)/AdBlue® level	3-57
Diesel Exhaust Fluid (DEF)/AdBlue® display warnings	3-58
Lower display	3-68
Keypad	3-70
Instrumentation - setup menu	3-71
Instrumentation - adjust menu	3-78
Performance instrumentation	3-85

4 OPERATING INSTRUCTIONS

COMMISSIONING THE UNIT

Before starting the engine	4-1
----------------------------------	-----

STARTING THE UNIT

Normal engine starting	4-5
Cold temperature operation	4-7

STOPPING THE UNIT

Stopping the machine and the engine	4-9
---	-----

MOVING THE UNIT

Powershift transmission	4-10
Selective Catalytic Reduction (SCR) system	4-18
Electronic steering system	4-20
Ground Speed Management (GSM)	4-21
Differential lock system	4-31
Power management	4-35
Constant engine speed	4-36
Headland Management System (HMS)	4-38
Engine compression brake (if equipped)	4-48

5 TRANSPORT OPERATIONS

ROAD TRANSPORT

Tractor warning lamps and Slow Moving Vehicle (SMV) symbol	5-1
Wide transport marker light	5-4
Operating the tractor warning lamps	5-5
Safe transport speed	5-6
Implement warning lamps and Slow Moving Vehicle (SMV) symbol	5-7
Safety chain	5-7

SHIPPING TRANSPORT

Securing the tractor for shipping	5-8
---	-----

RECOVERY TRANSPORT

Safety rules	5-9
Towing the tractor	5-10

6 WORKING OPERATIONS

GENERAL INFORMATION

Product overview	6-1
------------------------	-----

REAR POWER TAKE-OFF (PTO)

Power Take-Off (PTO) safety rules	6-2
Connecting the Power Take-Off (PTO)	6-4
Power Take-Off (PTO) operation	6-5

THREE-POINT HITCH

Identification	6-8
Link adjustment	6-9
Sway block adjustment	6-12
Mechanical float adjustment	6-13
Hitch quick coupler - Category IVN	6-14
Transport lock	6-17
Hitch operation	6-18
Rear remote hitch switch	6-23
Position control operation	6-24

Slip control operation	6-26
------------------------------	------

DRAWBARS AND TOWING ATTACHMENTS

Safety rules	6-27
Drawbar capacities	6-28
Scraper operation	6-31

TRAILER BRAKE COUPLER

Safety rules	6-32
Trailer brake connections	6-32

AUXILIARY POWER CONNECTIONS

External power and lighting connections	6-33
Cab power connections	6-35

HYDRAULIC REMOTE CONTROL VALVES

Valve couplers and connections	6-38
Optional circuits	6-45
Hydraulic remote valve transport lock	6-46
Right-hand armrest controls	6-47
Operating the lever controls	6-48
Operating the Joystick control	6-52
Remote valve display screens	6-56
Auto auxiliary mode operation	6-59
Auto depth control operation	6-62

BALLASTING THE TRACTOR

Guidelines	6-65
Weights, cast metal and liquid	6-69
Wheel slip	6-76

FRONT AND REAR AXLE

Tire safety	6-77
Pressure and load ratings	6-78
Wheel installation	6-85
Wheel tread settings	6-91

7 MAINTENANCE

GENERAL INFORMATION

Advice	7-1
Engine hood	7-2
Engine side shields	7-3
Opening the right-hand service door	7-4
Battery access	7-5
Power cut-off switch	7-6
Filling the fuel tank	7-8

Fuel tank capacity	7-9
Filling the Diesel Exhaust Fluid (DEF)/AdBlue® tank	7-10
Diesel Exhaust Fluid (DEF)/AdBlue® tank capacity.....	7-11
Tire and rim service.....	7-12
Tractor jacking points.....	7-14
Lubricants and capacities	7-16
Recommended engine oil for operating temperature ranges.....	7-17
General specification - Diesel fuel	7-18
General specification - Biodiesel fuels	7-19
Organic Acid Technology (OAT) coolant.....	7-21
Electrical specifications.....	7-22
Battery system.....	7-23
Auxiliary battery connections	7-25
Maintenance chart notes	7-27

MAINTENANCE CHART

Maintenance chart.....	7-28
------------------------	------

At warning message display

Air cleaner	7-30
Primary fuel filter	7-31
Fuel supply restricted (13L engines only)	7-31

Every 10 hours or daily

Engine oil level	7-32
Wheel bolt torque.....	7-32
Weight bolt torque	7-32
Transmission oil level.....	7-33
Hydraulic and axle oil level	7-34
Engine coolant level	7-35
Secondary cooling system level.....	7-35
Fuel level	7-36
Diesel Exhaust Fluid (DEF)/AdBlue® level.....	7-36
General tractor inspection	7-36

Every 50 hours

Fuel tank and fuel filter	7-37
Articulation hinge - Upper front	7-38
Oscillation hinge - Rear.....	7-39
Articulation hinge - Lower	7-39
Articulation cylinder - Front, left hand, right hand	7-40
Articulation cylinder - Rear, left hand and right hand	7-40
Hitch cylinder pin - Upper (if equipped).....	7-40
Hitch cylinder pin - Lower (if equipped).....	7-41
Hitch rockshaft - Left-hand and right hand	7-41
Hitch lift links and top link.....	7-42
Driveshaft carrier bearing.....	7-42

First 100 hours

Powershift transmission clutches	7-43
--	------

Every 600 hours

Engine oil and filter (see Note 3)	7-49
Engine fuel filter (see Note 4)	7-52
Engine fuel pre-filter	7-55
Fuel tank vent (see Note 6).....	7-58
Battery electrolyte level.....	7-59
Cab air filter, outside (see Note 1).....	7-60
Air tubing - Engine.....	7-61
Alternator - Water pump belt	7-61
Power Take Off (PTO) carrier bearing	7-62
Power Take Off (PTO) slip joint.....	7-62
Radiator and coolers	7-63
Cab recirculation filter	7-65

Every 1000 hours or yearly

Powershift transmission clutches.....	7-66
---------------------------------------	------

Every 1200 hours

Engine crankcase breather filter.....	7-66
Transmission oil and filter (see Note 4).....	7-70
Transmission vent	7-71
Engine air filters (see Note 2)	7-72
Diesel Exhaust Fluid (DEF)/AdBlue® supply module filter	7-78
Door lock and hinges	7-81

Every 1800 hours

Hydraulic oil and filters (see Note 4)	7-82
Hydraulic reservoir breather	7-84
Cab air filter, outside (see Note 1).....	7-85
Engine air tubing	7-86

Every 2400 hours

Engine coolant drain and flush	7-87
Secondary cooling system drain and flush	7-90

As required

Vehicle fire prevention	7-93
Remote valve couplers	7-94
Pressure cooling system hoses	7-94
Hydraulic system hoses	7-94
Tire pressure	7-94
Engine fan belt	7-95

Viscous fan drive	7-95
Cab fabric and carpet.....	7-96
Seat belt	7-96
Battery removal and installation	7-97
Hood lamps.....	7-99
Flood and work lamps	7-104
Fender tail light and warning light	7-107
Roof warning light	7-110
Wide transport marker light.....	7-112
Rotating beacon light.....	7-113
Interior lights.....	7-114

Fuse and relay locations

Fuse and relay locations	7-117
--------------------------------	-------

STORAGE

Placing in storage	7-125
Removing from storage.....	7-125

8 TROUBLESHOOTING

FAULT CODE RESOLUTION

Fault code retrieval	8-1
----------------------------	-----

ALARM(S)

Display warnings	8-4
Transmission disengages; neutral icon flashes	8-16

9 SPECIFICATIONS

Engine specifications	9-1
Power train and hydraulics	9-3
Lubricants and capacities	9-6
Speed charts	9-7
Vehicle dimensions and shipping weight	9-10
Maximum operating weight.....	9-12

10 ACCESSORIES

Farming system displays	10-1
Chemical tank mounting.....	10-2
General accessories.....	10-5

1 - GENERAL INFORMATION

Note to the owner

This manual contains important information about the safe operation, adjustment, and routine maintenance of your tractor. The manual is divided into ten chapters as outlined on the Contents page. Refer to the index at the end of this manual for locating specific items about your tractor.

Do NOT operate or permit anyone to operate or service this machine until you or the other persons have read this manual. Use only trained operators who have demonstrated the ability to operate and service this machine correctly and safely.

Store this operator's manual in the manual compartment behind the operator's seat in the vehicle. Make sure this manual is in good condition. Contact your dealer to obtain additional manuals.

Intended use

T9. series tractors with standard equipment and authorized attachments, are intended to be used for customary farming, land leveling and related agriculture operations (intended use). This tractor is not intended for forestry use or for use with loaders. The cab on this tractor does not offer sufficient protection for forestry work.

Installation of utility (dozer) blades, tile plows, front loaders or push bars on the tractor is not approved. Any tractor damage resulting from the installation and/or use of such equipment is not covered by the tractor warranty.

Consult an authorized dealer or CNH Industrial America LLC on changes, additions or modifications that can be required for this machine to comply with various regulations and safety requirements. Unauthorized modifications will cause serious injury or death. Anyone making such unauthorized modifications is responsible for the consequences.

Do not use this machine for any purpose or in any manner other than as described in the manual, decals, or other product safety information provided with the machine. These materials define the machine's intended use.

Use in any other way is considered as contrary to the intended use. The manufacture accepts no liability for

Your dealer will instruct you in the general operation of your new equipment. Your dealer's staff of factory-trained service technicians will be glad to answer any questions that may arise regarding the operation of your machine. New Holland Top Service is also available. Go to www.newholland.com.

ATTENTION: *The engine and fuel system on your machine is designed and built to government emissions standards. Tampering by dealers, customers, operators and users is strictly prohibited by law. Failure to comply could result in government fines, rework charges, invalid warranty, legal action and possible confiscation of the machine until rework to original condition is complete. Engine service and/or repairs must be done by a certified technician only!*

any damage or injury resulting from this misuse and these risks must be born solely by the user.

Compliance with and strict adherence to the conditions of operation, service and repair as specified by the manufacturer also constitute essential elements for the intended use.

All persons who will be operating this machine shall possess a valid local vehicle operating permit and/or other applicable local age work permits.

This tractor must be operated, serviced and repaired only by persons familiar with all its particular characteristics and acquainted with the relevant safety rules (accident prevention).

The accident prevention regulations, all other generally recognized regulations on safety and occupational medicine and the road traffic regulations must be observed at all times.

Any arbitrary modifications carried out on the tractor will relieve the manufacturer of all liability for any resulting damage or injury.

CNH Industrial America LLC technical manuals

Manuals are available from your dealer for your machine. Your dealer can expedite your order for operator manuals and parts catalogs.

Always give the machine name, model and Product Identification Number (PIN) of your machine so your dealer can provide the correct manuals for your machine.

The company is continually striving to improve its products and therefore reserves the right to make improvements and changes when it becomes practical and possible to do so, without incurring any obligation to make changes or additions to the equipment sold previously.

Manual scope and required training level

This manual provides information on the intended use of your tractor under the conditions foreseen by the manufacturer during normal operation, routine service and maintenance and periodic service and maintenance.

Normal operation is use of the tractor for the purpose intended by the manufacturer by an owner/operator who is familiar with the tractor and the mounted or towed equipment, and who is complying with the information on operation and safe practices, provided in this manual and by the decals on the tractor and the equipment.

Normal operation includes such actions as preparing the tractor for storage and removing the tractor from storage, adding or removing ballast, connecting and disconnecting mounted or towed equipment, raising and lowering components into or out of work position, adjusting tractor settings for specific field or crop settings, etc.

Routine service and maintenance are those actions which must be performed daily to maintain proper tractor function by an owner/operator who is familiar with tractor characteristics, and who is complying with the information on routine service and safe practices in this manual and in the decals on the tractor.

Routine service and maintenance includes such actions as fueling, cleaning, washing, topping off fluid levels, greasing, and replacing consumable articles such as lamp bulbs.

Periodic service and maintenance are those actions which must be performed at regularly defined intervals

All data given in this manual is subject to production variations.

NOTICE: *Operating and service messages displayed on the electronic operating panel may vary from what is shown in the manual. If this occurs, heed the latest instructions on the electronic operating panel.*

Dimensions and weights are approximate only and the illustrations do not necessarily show the machine in standard condition. For exact information about any particular machine, please consult your dealer.

to maintain proper tractor function by an owner/operator who is familiar with tractor characteristics, and who is complying with the information on periodic service and safe practices in this manual and in the decals on the tractor.

Periodic service and maintenance includes such actions as checking, cleaning and changing air filters, changing engine oil and filters, changing transmission oil and filters, changing front axle and wheel hub fluids, changing coolant, etc.

Some actions in the periodic service and maintenance chart are beyond the knowledge and skills of the owner/operator: for example, engine valve adjustment, fuel injector nozzles. For these actions, the manual instructs the owner/operator to have the action performed by their authorized dealer.

This manual does not contain all the information related to periodical service and maintenance, converting and repairs to be carried out by professional service personnel. These actions require special facilities, technical skills, and/or tools which are not supplied with the machine.

Converting is changing the tractor configuration for a specific crop or soil condition and requires rebuilding or adding components to the vehicle: for example, installation of dual wheels. Repairing is the disassembly and assembly of the tractor to restore proper operation after a component failure or degradation of performance.

Your tractor

This manual covers the T9.435, T9.480, T9.530, T9.565, T9.600, T9.645, and T9.700 models.

References are made within this manual of “row crop models” and “high power models”.

Row crop models include T9.435, T9.480, T9.530, and T9.565 models.

High power models include T9.600, T9.645, and T9.700 models.

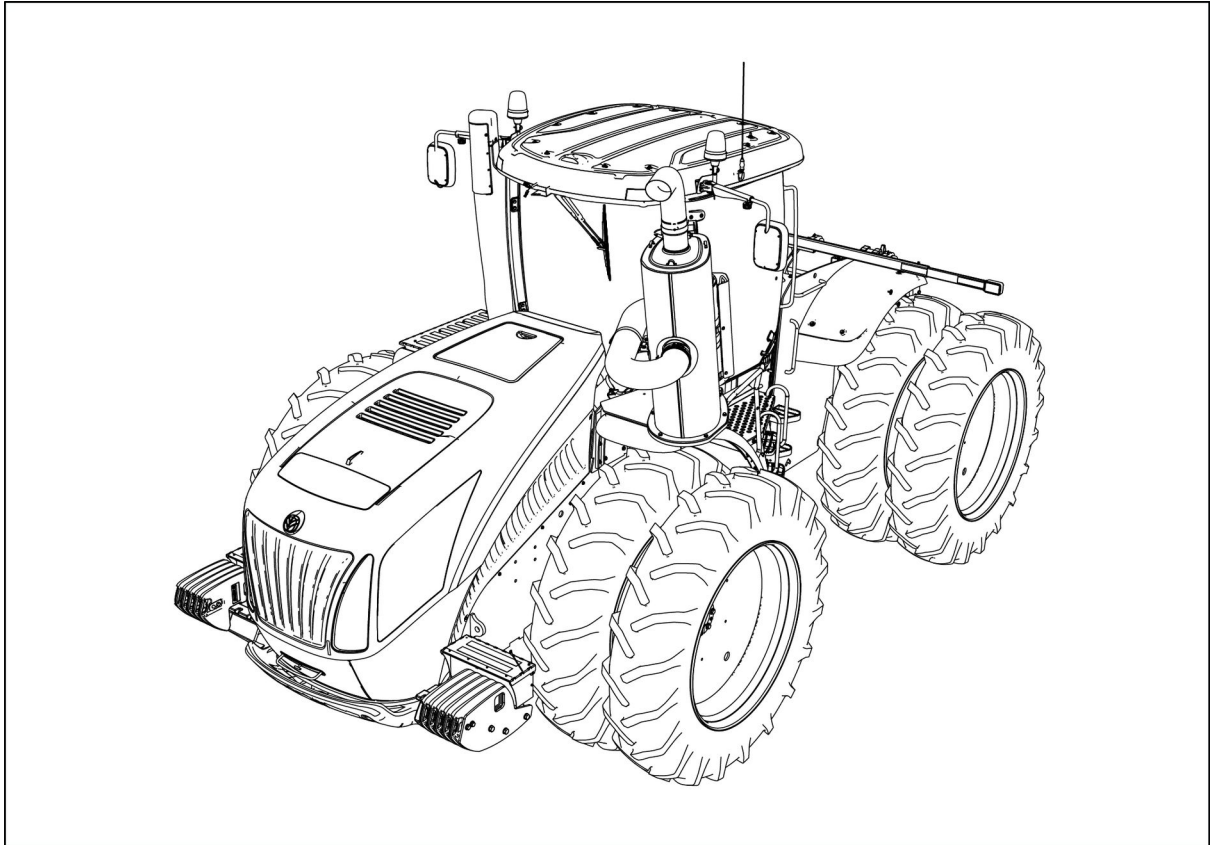

RAIL13TR04816FA 1

New Holland T9. series tractor

Electro-Magnetic Compatibility (EMC)

Interference may arise as a result of add-on equipment that may not necessarily meet the required standards. As such interference can result in serious malfunction of the unit and/or create unsafe situations, you must observe the following:

- The maximum power of emission equipment (radio, telephones, etc.) must not exceed the limits imposed by the national authorities of the country where you use the machine
- The electro-magnetic field generated by the add-on system should not exceed **24 V/m** at any time and at any location in the proximity of electronic components
- The add-on equipment must not interfere with the functioning of the on board electronics

Failure to comply with these rules will render the NEW HOLLAND warranty null and void.

Product identification

Tractor model and product identification number

Write your model number, Product Identification Number (PIN), and serial number of major components on the lines provided. If needed, give these numbers to your dealer when you need parts or information for your machine.

CNH Industrial America LLC MADE IN U.S.A.		 NEW HOLLAND AGRICULTURE	
Type / Model & Designation Tipo / Modelo & Designación Tipo / Modelo & Designación		Racine, WI 53404 U.S.A.	
Product Identification Number (PIN) Número de Identificación de Producto (PIN) Número de Identificación del Producto (PIN)		Bar Code	
Base Serial Number Base Número de Serie Número de Serie Base		Model Year	
Year of Construction Año de Fabricación Año de Construcción		47736647 A	

RAIL14TR02260EA 1

Model :

PIN:

NOTE: Located on the front right-hand side plate in front of front axle.

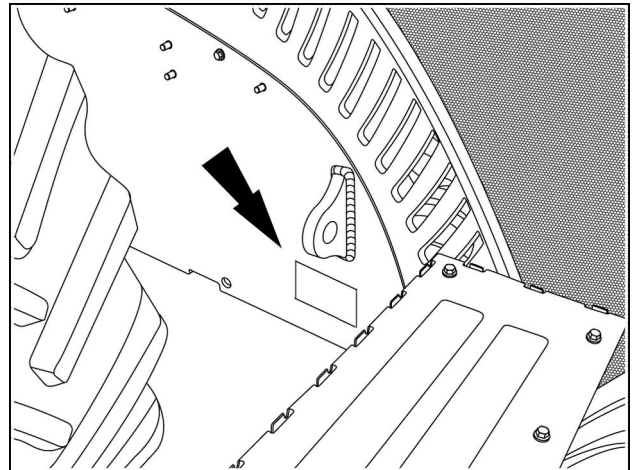

RCPH11FWD114BAM 2

Roll Over Protective Structure (ROPS) serial number

NOTE: Located under the instructional seat.

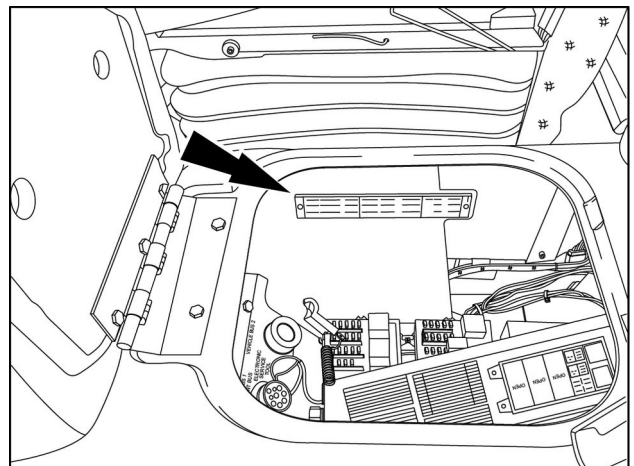

RAIL13TR04833AA 3

Thank you so much for reading.
Please click the “Buy Now!”
button below to download the
complete manual.



After you pay.

You can download the most
perfect and complete manual in
the world immediately.

Our support email:

ebooklibonline@outlook.com