

ORIGINAL INSTRUCTIONS

**BMI72H**

**BMI84H**

**Front Blade for Compact Tractor  
Attachment**

**OPERATOR'S MANUAL**

**Part number 48082151**

2<sup>nd</sup> edition English

January 2017

*Replaces part number 84234073*



# Contents

---

## 1 GENERAL INFORMATION

Note to the owner.....	1-1
Intended use.....	1-2
Product identification .....	1-3
Operator's manual storage on the machine Roll Over Protective System (ROPS) .....	1-4
Operator's manual storage on the machine (Cab) .....	1-5
Machine orientation.....	1-6
Machine components.....	1-7

## 2 SAFETY INFORMATION

For pictorial safety signs.....	2-1
For text safety sign .....	2-2
Safety rules.....	2-3
Ecology and the environment .....	2-7
Safety signs .....	2-8
Instructional signs .....	2-10

## 3 TRANSPORT OPERATIONS

### Road transport

Road transport.....	3-1
---------------------	-----

## 4 WORKING OPERATIONS

### General information

Blade - Assemble.....	4-1
Hydraulic angling - Installation .....	4-3
Hose - Installation .....	4-5
Blade - Mounting .....	4-6
Blade - Removal.....	4-7
Blade - Operation.....	4-8

## 5 MAINTENANCE

### General information

Safety rules.....	5-1
-------------------	-----

### Maintenance planning

Maintenance planning.....	5-2
---------------------------	-----

### Every 4 hours

Pivot points - Remove dirt .....	5-3
Angling cylinders - Remove dirt .....	5-4

---

**Every 8 hours**

Grease points - Lubricate..... 5-5

**Every month**

Moving parts - Lubricate..... 5-6

**As necessary**

Pivot pin - Lubricate ..... 5-7

**Storage**

Preparation for storage ..... 5-7

**6 SPECIFICATIONS**

General specification table ..... 6-1

**7 ACCESSORIES**

Accessories..... 7-1

**8 FORMS AND DECLARATIONS**

Delivery report - Owner copy - Owner copy ..... 8-1

Delivery report - Dealer copy - Dealer copy ..... 8-2

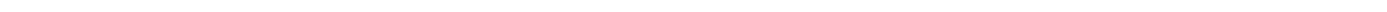

# 1 - GENERAL INFORMATION

## Note to the owner

This manual contains information concerning the adjustment and maintenance of your new equipment. You have purchased a dependable machine, but only by proper care and operation can you expect to receive the performance and long service built into this equipment. Please have all operators read this manual carefully and keep it available for ready reference.

You CASE IH dealer will instruct you in the general operation of your new equipment. (Refer to the 'Delivery Report' at the back of this manual.) Your dealer's staff of factory-trained service technicians will be glad to answer any questions that may arise regarding the operation of your machine.

Your CASE IH dealer carries a complete line of genuine CASE IH service parts. These parts are manufactured and carefully inspected to insure high quality and accurate fitting of any necessary replacement parts. Be prepared to give your dealer the model and product identification number of your new equipment when ordering parts. Locate these numbers now and record them below. Refer to the 'General Information' section of this manual for the location of the model and product identification numbers of your machine.

### PLEASE RECORD THE FOLLOWING INFORMATION

**Model**

\_\_\_\_\_

**Product Identification Number (PIN)**

\_\_\_\_\_

**Date Purchased**

\_\_\_\_\_

**Header Width (As Applicable)**

\_\_\_\_\_

	<p>This is the safety alert symbol. It is used with and without signal words to alert you to potential personal injury hazards. Obey all safety messages that follow this symbol to avoid possible death or injury.</p>
---	---

### **⚠ WARNING**

**Illustrations in this manual may show protective shielding open or removed to better illustrate a particular feature or adjustment.  
Replace all shields before operating the machine.  
Failure to comply could result in death or serious injury.**

W0012A

### IMPROVEMENTS

CNH INDUSTRIAL AMERICA LLC is continually striving to improve its products. We reserve the right to make improvements or changes when it becomes practical and possible to do so, without incurring any obligation to make changes or additions to the equipment sold previously.

## Intended use

All products are designed to give safe, dependable service if they are operated and maintained according to instructions. Read and understand this manual before operation.

This manual has been prepared to assist the owner and operators in the safe operation and suitable maintenance of the equipment. The information is applicable to products at the time of manufacture and does not include modifications made afterwards.

Read and understand this operator's manual before attempting to put equipment into service. Familiarize yourself with the operating instructions and all the safety recommendations contained in this manual and those labeled on the equipment and on the tractor. Follow the safety recommendations and make sure that those with whom you work follow them.

## Illustrations

The illustrations may not necessarily reproduce the full detail and the exact shape of the parts or depict the actual models, but are intended for reference only.

## Product identification

### Product Identification Number (PIN) plate

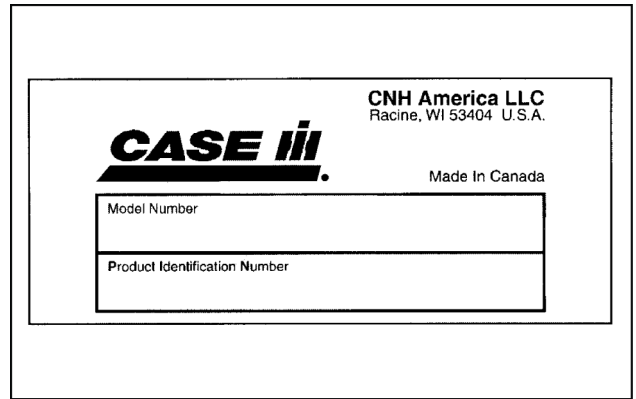

NHIL16CT01588AA 1

## Operator's manual storage on the machine Roll Over Protective System (ROPS)

The operator's manual for the front blade, must be stored in a compartment **(1)** located in the rear of the operator's seat back and be kept available for use by all operators.

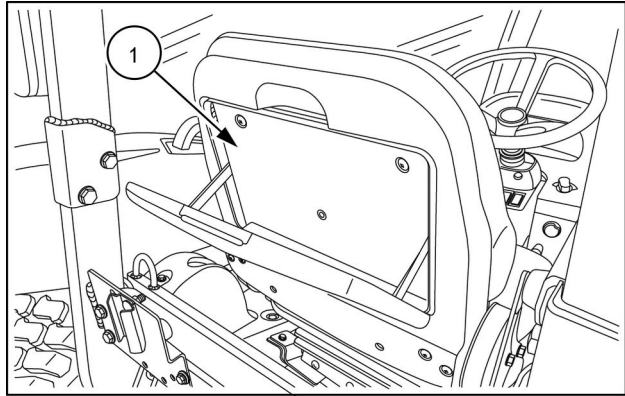

NHIL13CT01163AA 1

## Operator's manual storage on the machine (Cab)

The operator's manual for the front blade, must be stored in a compartment **(1)** located in the rear of the operator's seat back and be kept available for use by all operators.

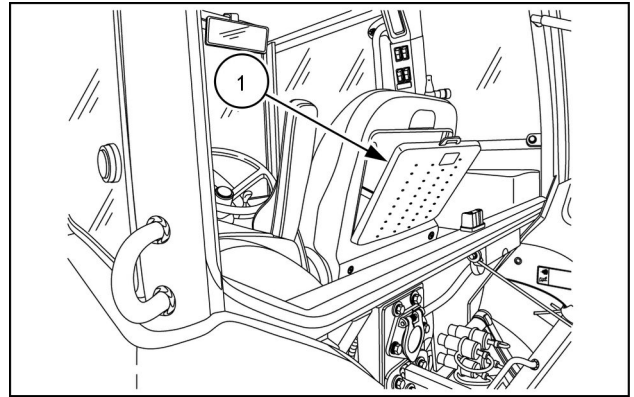

NHIL15CT00625AA 1



**Buy Now**



Our support email:

[ebooklibonline@outlook.com](mailto:ebooklibonline@outlook.com)