

Farmall® 55JXM
Farmall® 65JXM
Farmall® 75JXM
Tractor

OPERATOR'S MANUAL

Part number 48134687
1st edition English
July 2017



Contents

1 GENERAL INFORMATION

Note to the Owner	1-1
General information and safety	1-3
Product Identification	1-4
Ecology and the Environment	1-6

2 SAFETY INFORMATION

Safety rules	2-1
Safety precautions	2-1
Personal safety	2-1
Driving the tractor	2-2
Operating the tractor	2-3
Operating the Power Take-Off (PTO)	2-4
Servicing the tractor	2-5
Diesel fuel	2-5
Trailer hitching	2-7
General and Safety Decals	2-8
International symbols	2-13
Fuel saving tips for optimum performance	2-14

3 CONTROLS AND INSTRUMENTS

Access to operator's platform

Before Operating	3-1
------------------------	-----

Operator's seat

Operator's seat	3-2
Operator's seat belt	3-3

Forward controls

Instrument cluster	3-4
Hand controls and switches	3-8
Hydrostatic Steering	3-11
Transmission shuttle shift lever	3-11

Left-hand side controls

Clutch Pedal	3-12
Parking Brake	3-12
Creeper lever (where fitted)	3-12
Splitter lever (where fitted)	3-13
Power Take-Off (PTO) - Control identification	3-13
4WD Lever	3-14

Right-hand side controls

Foot Accelerator	3-14
Differential lock pedal - Control identification	3-15
Foot Brake Pedal	3-15

Overhead controls

Roll Over Protective Structure (ROPS) frame - Position	3-16
--	------

Transmission

Transmission - Control identification	3-18
---	------

4 OPERATING INSTRUCTIONS

Commissioning the unit

Before Operating	4-1
Running-In Procedure	4-2

Starting the unit

Starting the tractor with jumper cables	4-3
Starting the Engine	4-3

Stopping the unit

Stopping the engine	4-5
---------------------------	-----

5 TRANSPORT OPERATIONS

Road transport

Carrying the tractor on a transporter	5-1
---	-----

Recovery transport

Towing the tractor.....	5-1
-------------------------	-----

6 WORKING OPERATIONS

INTER COOLER & TURBO CHARGER LDA

Intercooler	6-1
Turbocharger - Control identification	6-1
Oil cooler	6-2

POWER TAKE OFF (PTO)

Power Take-Off (PTO) operating precautions	6-2
Attaching Power-Take Off (PTO) driven equipment	6-3
Power Take-Off (PTO) - Control identification	6-5
Power Take-Off (PTO) protective cap and guard.....	6-5
Ground drive PTO (where fitted)	6-7

THREE-POINT LINKAGE

Three-point hitch - Control identification.....	6-10
Attaching 3-point implements.....	6-11
Three-point hitch adjustments.....	6-12
Remote Valves (If fitted).....	6-14
Drawbars and towing hitches - Adjust TOWING ATTACHMENTS	6-15

HYDRAULIC SYSTEM

Hydraulic systems - Check	6-17
Position control operation	6-18
Draft Control Operation.....	6-18
Combined position and Draft control - Mixed control	6-18
Float Operation	6-19
Lift-O-Matic Button	6-19
Height Limiter - Lift -O- Matic (If fitted)	6-20
Sensitivity Control	6-20
Response Control or Drop rate Control	6-20
Divert Valve External Supply Port or Tap off	6-21

WHEEL TRACK ADJUSTMENT

FRONT WHEEL TRACK ADJUSTMENT (two wheel drive).....	6-21
Hydrostatic Steering Right side - illustrated	6-22
Reassembly After Setting Track Width	6-22
Front wheel track adjustment 4WD	6-23
Front wheel toe in	6-24
Rear wheel track adjustment	6-24

BALLASTING AND TIRES

Ballasting of Tires Selecting ballast	6-25
Rear wheel weights.....	6-27
Front Weights.....	6-27
Liquid ballast	6-28
Tire inflation.....	6-28
Front Tire Pressure and Permissible Loads	6-29

7 MAINTENANCE

General information

Introduction	7-1
Safety precautions.....	7-1
During the first 50 hour operation	7-1
First 50 Hours Service.....	7-1
Preventing System Contamination	7-2
Flexibility of Maintenance Intervals.....	7-2
Lubrication and maintenance chart.....	7-2
Refueling the tractor.....	7-2
Fuel Requirements	7-2
Diesel fuel quality specifications.....	7-2

Fuel storage	7-3
Guards.....	7-3

Maintenance planning

Maintenance chart.....	7-5
------------------------	-----

Every 10 Hours of Operation or Daily (Whichever Occurs First)

Check engine oil level	7-6
Radiator coolant level check	7-6
Air pre-cleaner - Cleaning (If fitted)	7-7
Drain water from Fuel Filter	7-7
Water Separator	7-7

EVERY 50 HOURS

Air pre-cleaner - Cleaning	7-8
Clutch pedal free play - check	7-8
Brake pedal free play - check	7-8
Wheel nut and bolt torque	7-9
Tire Pressures and Condition.....	7-9
Fan/alternator belt - adjustment	7-10
Grease fittings	7-10
Grease fittings 4 WD	7-11
Battery electrolyte level - Check.....	7-12
Front Axle Housing Oil Level - 4WD.....	7-12

EVERY 300 HOURS

SERVICE THE ENGINE AIR CLEANER OUTER ELEMENT	7-13
Change the fuel filter (Primary)	7-16
Fuel injection system - Bleed.....	7-17
Fuel Feed Pump Filter.....	7-17
Change engine oil	7-18
Change Engine Oil Filter	7-19
Transmission oil Common oil level (Transmission/Hydraulic/Steering)	7-19
Hydraulic oil filter	7-19
Front Axle Reduction Hubs - 4WD	7-20
4WD front axle swivel bearings.....	7-20
Drive Shaft Sleeve for 4WD Front Axle Connection.....	7-20
PTO clutch lever free play	7-21

EVERY 600 HOURS

Replacing the fuel filters	7-21
Check the valve tappet clearance	7-22
Transmission housing breather - Check.....	7-22
Clean, Re-grease and Adjust Front Wheel Bearing	7-22
Fuel injectors - servicing	7-22
Toe-in adjustment.....	7-22

EVERY 1200 HOURS OR ANNUALLY

Hydraulic/Transmission Fluid Change.....	7-23
Radiator Drain and Refill the Cooling System	7-24
Front Axle Housing Oil Level - 4WD.....	7-25
Draining the Oil from the Front Axle Final Drive Hub - 4WD	7-25
Brake oil (If applicable)	7-25
Fuel tanks - Cleaning.....	7-26

GENERAL MAINTENANCE

Bleeding the fuel injection system.....	7-26
Engine idle speed	7-26
Headlight - Check	7-26
Work lamps.....	7-27
Position Lights.....	7-27
Canopy lights - Adjust	7-27
Fuse replacement	7-28
Battery Welding PROTECTING THE ELECTRONIC AND ELECTRICAL SYSTEMS DURING BATTERY CHARGING OR WELDING	7-29
Dust screen.....	7-31

Storage

Tractor storage	7-31
-----------------------	------

8 TROUBLESHOOTING

Fault code resolution

Maintenance - Troubleshooting.....	8-1
------------------------------------	-----

9 SPECIFICATIONS

General dimensions	9-1
Engine	9-2
Cooling System.....	9-3
Power Take Off (PTO)	9-3
Clutch System	9-3
Three-point linkage.....	9-3
Hydraulic System.....	9-3
Electrical System	9-3
Steering.....	9-4
Brakes	9-4
Transmission - Speeds	9-5
Lubricants and coolants	9-11

1 - GENERAL INFORMATION

Note to the Owner

This manual contains information concerning the adjustment and maintenance of the 55 JXM / 65 JXM / 75 JXM tractors. Proper care and operation is must for the best performance and long service of the machine. The operator must read this manual carefully and keep the manual available for reference.

Your CASE IH dealer will instruct you in the general operation of your new equipment.
See **Delivery report** at the back of this manual.

Your dealer's staff of factory-trained service technicians will be glad to answer any questions that may arise regarding the operation of your tractor. CASE IH top service is also available. Call at 1800-419-0124..

Your CASE IH dealer carries a complete line of genuine CASE IH service parts. These parts are manufactured and carefully inspected to insure high quality and accurate fitting of any necessary replacement parts. Be prepared to give your dealer the model and product identification number of your new equipment when ordering parts. Locate these numbers now and record them below. Refer to the 'General Information' section of this manual for the location of the model and product identification numbers of your machine.

Please record the following information

Model

Vehicle Identification Number (VIN)

Date of purchase

Attachment model

Attachment model

	This is the safety alert symbol. It is used with and without signal words to alert you to potential personal injury hazards. Obey all safety messages that follow this symbol to avoid possible death or injury.
---	--

WARNING

Illustrations in this manual may show protective shielding open or removed to better illustrate a particular feature or adjustment.

Replace all shields before operating the machine.

Failure to comply could result in death or serious injury.

W0012A

Improvements

CNH Industrial N.V. is continually striving to improve its products. CNH Industrial N.V. reserves the right to make improvements or changes when it becomes practical and possible. CNH Industrial N.V. does not incur any obligation to make changes or additions to the equipment sold previously.

Intended use

Do not use this machine for any purpose or in any manner other than as described in the manual, decals, or other product safety information provided with the machine. These materials define the machine's intended use.

Use only approved accessories and attachments designed for your machine. Consult your dealer on changes, additions or modifications that may be required for your machine. Do not make any unauthorized modifications to your machine.

ATTENTION: *The engine and fuel system on your machine is designed and built to government emissions standards. Tampering by dealer, customers, operators and users is strictly prohibited by law. Failure to comply could result in government fines, rework charges, invalid warranty, legal action and possible confiscation of the machine until rework to original condition is completed. Engine service and/or repairs must be done by a certified technician only!*

Operator's age

All persons who will be operating this machine shall possess a valid local vehicle operating permit and/or other applicable local age work permits.

WARNING

IMPROPER OPERATION OF THIS MACHINE CAN CAUSE DEATH OR SERIOUS INJURY.

MAKE SURE THAT EVERY OPERATOR:

-is instructed in the safe and proper use of this machine.

-reads and understands the operator's manual for this machine.

-reads and understands ALL safety signs on the machine.

Failure to comply could result in death or serious injury.

W0188A

Read and thoroughly understand this manual before operating this machine. If you are an inexperienced operator, study this manual and receive operating instructions from an experienced operator. Your dealer can assist you in learning machine operation and show you proper operating procedures. Keep this manual readily available, preferably with the machine. If the original manual is damaged, order a new one from your dealer.

General information and safety

TO THE OWNER

GENERAL

This Manual has been prepared to assist you in the correct procedure for running in, driving, operating and for the maintenance of your new tractor. Your tractor, which is designed to power and propel itself, is intended for use in normal and customary agricultural applications.

Read this Manual carefully and keep it in a convenient place for future references. If at any time you require advice concerning your tractor, do not hesitate to contact your Authorized Dealer. He has company trained personnel, genuine manufacturers' parts and the necessary equipment to carry out all your service requirements

Your tractor has been designed and built to give maximum performance, economy and ease of operation under a wide variety of operating conditions. Prior to delivery, the tractor was carefully inspected, both at the factory and by your dealer to ensure that it reaches you in optimum condition. To maintain this condition and trouble-free operation, it is important that the routine services, as specified in this manual, are carried out at the recommended intervals.

CLEANING THE TRACTOR

While cleaning the tractor, particularly when using a high pressure tractor washing equipment, precaution has to be taken to safeguard electrical / electronic components and connections. The pressure generated by some of these machines is such that complete protection against water ingress cannot be guaranteed. While washing the tractor, using a high pressure washing machine, do not stand too close to the tractor and avoid directing the jet at electrical connections, breathers, seals, filler caps, etc. Never direct a cold water jet at a hot engine or exhaust.

SAFETY

Chapter 2 include the list of precautions to be observed to ensure your safety and the safety of others. Read the

NOTE: Reference positions (Left / Right / Front / Rear) of Components and Decals indicated in this Operator Manual taken with a view when operator is seated on Operator Seat.

safety precautions and follow the advice offered before operating the tractor.

FIRST 50 HOUR SERVICE

After you have operated the tractor for 50 hours, take your tractor with warranty booklet to your dealer. He will then perform the manufacturer recommended 50 hour service and complete the service report. Ensure the completion of the coupon and signature of Service Manager/Dealer.

SERVICE PARTS

It should be pointed out that genuine parts have been examined and approved by the company. The installation and/or usage of 'non-genuine' products could have negative effects upon the design characteristics of your tractor and thereby affect its safety. The Company is not liable for any damage caused by the use of 'non genuine' parts and accessories.

Only Genuine CASE IH replacement parts should be used. Use of non-genuine parts may invalidate legal approvals associated with this product.

It is prohibited to carry out any modifications to the tractor unless specifically authorized, in writing, by the After Sales Service department of the Company.

WARRANTY

Your tractor is warranted according to the current legislation in your country and with contractual agreements reached with the dealer at the time of sale. However, the warranty is no longer valid if the rules and instructions for the use and maintenance of the tractor described in this manual are not observed. For more details on warranty, please refer Warranty Booklet supplied along with this manual.

Product Identification

Vehicle Identification Plate (VIP)

Inside of right-hand centre panel

The first line represents tractor serial number and model. Second line represents unit code and engine serial number followed by transmission serial number and product code.

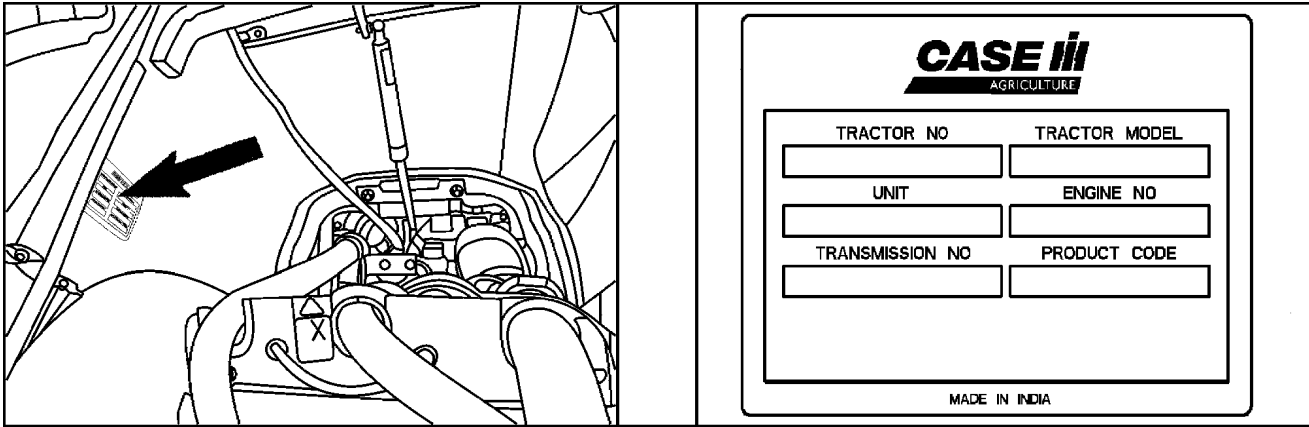

GNIL17TRO0081FA 1

Vehicle Identification Number (VIN)

The tractor serial number, unit code and engine number are stamped on the top of the main clutch housing. These numbers are also repeated on the vehicle identification decal reproduced above.

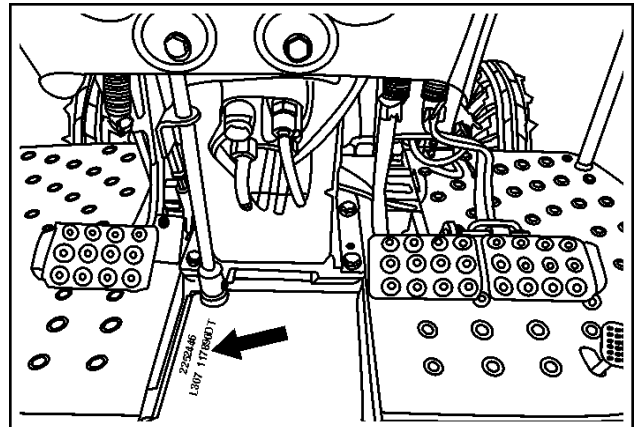

GNIL13TR00002AA 2

Engine identification

The engine serial number stamped on right side of the engine cylinder block. This number is repeated on VIP. Record the engine serial no. below for quick reference.

Engine serial no. _____

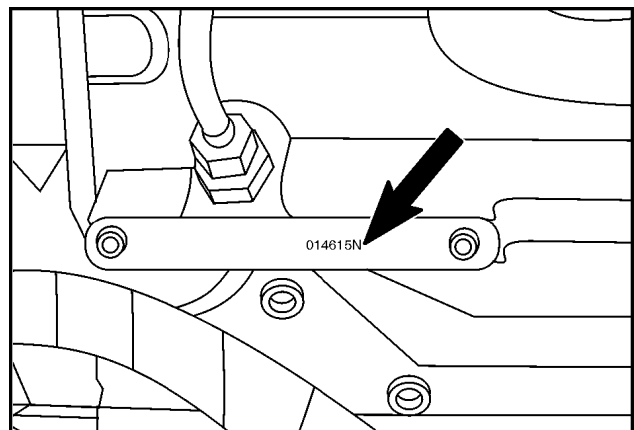

GNIL13TR00003AA 3

Transmission identification

Transmission serial number is stamped on top of transmission housing, beside the brake pedal. This information is repeated on the VIP. Record the transmission serial number below for quick reference.

Transmission serial no. _____

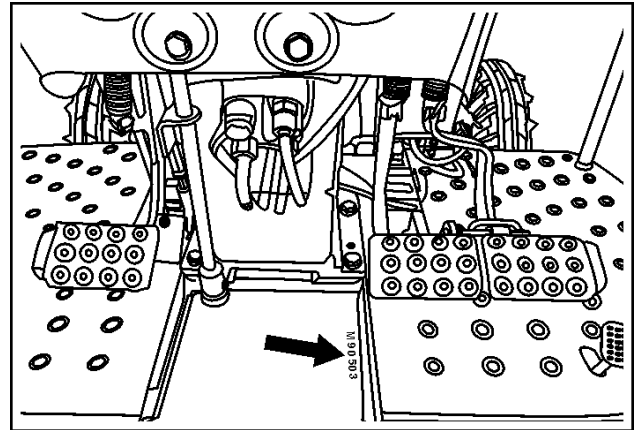

GNIL13TR00004AA 4

Ecology and the Environment

Soil, air and water are vital factors that impact agriculture and life in general. Where legislation does not yet rule the treatment of some of the substances which are required by advanced technology, common sense should govern the use and disposal of products of a chemical and petrochemical nature.

The following are recommendations which may be of assistance:

- Become acquainted with and ensure that you understand the legislation applicable to your country.
- Where no legislation exists, obtain information from suppliers of oils, filters, batteries, fuels, cleaning agents, etc., with regard to their effect on man and nature and how to safely store, use and dispose off these substances.

HELPFUL HINTS

1. Avoid filling tanks using open containers or inappropriate pressurized fuel delivery systems which may cause excessive spillage them contain substances which can be harmful to your health.
2. Modern oils contain additives. Do not burn contaminated fuels and/or waste oils in ordinary heating systems.
3. Avoid spillage while draining used engine coolant mixtures, engine, gearbox and hydraulic oils, brake fluids, etc. Do not mix drained brake fluids or fuels with lubricants. Store them safely until they can be disposed off in a proper way to comply with local legislation.
4. Modern coolant mixtures, i.e. antifreeze and other additives, should be replaced every 12 months or 1200 Hours. They should not be allowed to get into the soil but should be collected and disposed off safely.
5. Repair any leaks or defects in the engine cooling or hydraulic system immediately.
6. Protect hoses during welding as penetration of weld splatter may burn a hole or weaken them, causing the losses of oil, coolant etc.

2 - SAFETY INFORMATION

Safety rules

General safety rules

Modifications made to this machine may increase the likelihood or potential for debris accumulations that would normally not be present. Modifications include frame-mounted attachments, plates, screens, or other aftermarket equipment. Operators of modified machines must be aware of accumulations of organic debris and/or material and overall machine cleanliness.

Modified machines require additional and more frequent inspection and cleaning during usage. The machine may require inspection and cleaning multiple times per day during usage. Operators must be aware of the operating environment and conditions. Operators must take appropriate actions to maintain the machines during use. In particular, pay attention to the following machine areas:

1. In and around the engine compartment
2. Hot exhaust components
3. Moving, turning, or rotating machine components

Operators that operate the machine in a typical applications and/or conditions must be aware of accumulations of organic debris and/or material and overall machine cleanliness. Pay particular attention where material accumulations are possible or may result.

Machines that operate in a typical applications or conditions require additional and more frequent inspection and cleaning during usage. The machine may require inspection and cleaning multiple times per day during usage. Operators must be aware of the operating environment and conditions. Operators must take appropriate actions to maintain the machines during use. In particular, pay attention to the following machine areas:

1. In and around the engine compartment
2. Hot exhaust components
3. Moving, turning, or rotating machine components

Safety precautions

A careful operator is the best operator. Most accidents can be avoided by observing certain precautions. To help prevent accidents, read and take the following precautions before driving, operating or servicing the tractor. Equipment should be operated only by those who are responsible, trained & authorized to do so.

PRECAUTIONARY STATEMENTS

Throughout this manual you will see text, preceded by the words NOTE, ATTENTION, IMPORTANT, CAUTION, WARNING or DANGER. Such text has the following significance

Personal safety

CAUTION

The word CAUTION is used where a safe behavioral practice, according to operating & maintenance instructions and common safety practices will protect the operator and others from accident involvement.

WARNING

Machine Safety

NOTE: *This text stresses a correct operating technique or procedure.*

ATTENTION: *This text warns the operator of potential machine damage if a certain procedure is not followed.*

NOTICE: *This text informs the reader about something that he needs to know to prevent minor machine damage if a certain procedure is not followed*

The word WARNING denotes a potential or hidden hazard which could possibly cause serious injury. It is used to warn.

DANGER

The word DANGER denotes a forbidden practice in connection with a serious hazard

Failure to follow the CAUTION, WARNING and DANGER instructions may result in serious injury to body or even death.

THE TRACTOR

Throughout this manual you will see text, preceded by the words NOTE, ATTENTION, IMPORTANT, CAUTION, WARNING or DANGER. Such text has the following significance:

1. Read this Operator's Manual carefully before using the tractor. Lack of operating knowledge can lead to accidents.
2. To prevent falls, use the hand rails and step plates while getting on and off the tractor. Keep steps and platform clear of mud and debris
3. Replace all missing, illegible or damaged safety decals.
4. Keep safety decals free of dirt or grime.



1D0B2014015 1

5. Do not permit anyone, except the operator to ride the tractor. It is unsafe for extra passengers to travel.
6. Always keep children away from the tractor and farm machinery
7. You or any body else should not modify or alter tractor or any of its components without consulting your authorized dealer.
8. Install all guards before starting the engine or operating the tractor.
9. Tractor wheels are very heavy. Handle with care and ensure while storing that they should not topple down and cause injury to anybody.

Driving the tractor

1. Always sit in the driver's seat while starting or driving the tractor
2. When driving on public roads, have consideration for other road users. Keep tractor in left lane (slow moving traffic lane) so as to allow traffic to pass besides you. Do not exceed the legal speed limit set for agricultural tractors.
3. Dip the tractor lights when meeting a vehicle at night. Make sure the lights are adjusted to prevent blinding the driver of an oncoming vehicle.
4. Reduce speed before turning or applying the brakes. Brake both wheels simultaneously when making an emergency stop. Ensure that both brake pedals are locked together when travelling at road speeds or when on public roads. Ensure correct operation of trailer brakes.

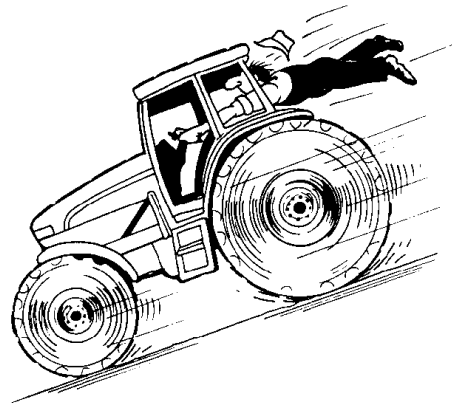

1D0B2014017 2

7. Do not switch off the engine on slope to avoid engine over speeding or engine breakage condition.
8. Any towed vehicle whose total weight exceeds that of the towing tractor must be equipped with brakes for safe operation.
9. Never try to apply the differential lock while turning. When engaged, the differential lock will prevent the tractor from turning.



1D0B2014016 1

Buy Now



Our support email:

ebooklibonline@outlook.com