

MAXXFARM 25,30

Operator's Manual

52105402

Contents



1. General Notices for Safety

1-1. Before using the tractor	1-1
1-2. Safety Precautions (Read this for safety before using)	
(1) Notices before using	1-3
(2) Notices when starting Engine	1-5
(3) Notices while operating/using the tractor	1-6
(4) Notices when connecting Implement	1-8
(5) Notices when towing the tractor	1-8
(6) Notices when transporting the tractor	1-9
(7) Notices when parking tractor	1-9
(8) Notices when checking tractor after work	1-10
(9) Notices when handling Diesel Fuel	1-11
(10) Operator Protective Structure (OPS)	1-11
(11) Electromagnetic Interference (EMC)	1-12
(12) Noise	1-12
1-3. Long-term storage	
(1) Preparation for storage	1-13
(2) Check & Maintenance during storage	1-14
(3) Preparation for Reuse	1-14
1-4. Notices for “Use & Disposal” related to Environment Preservation . . .	1-15
1-5. Symbols	1-16
1-6. Safety Decals	
(1) Handling and Maintenance of Safety Decals	1-17
(2) Safety Decals and attaching position	1-17



2. Instruction for Safe operation

(1) The name of each part	2-1
2-1. Boarding and Exiting the tractor	
(1) Boarding the tractor	2-2
(2) Driver’s seat (HST type)	2-2
(3) Seat adjustment	2-3
(4) Seat belt	2-3
(5) Exiting the tractor	2-4
2-2. Safety Device	
(1) Hood (Bonnet)	2-5
(2) Fender	2-5
(3) PTO safety cover and protection cap	2-5
(4) Foldable Safety frame (R.O.P.S type)	2-6

Contents



3. Instruments and Controls

3-1. Instrument Panel and Switches

(1) The name of each part	3-1
(2) Key switch	3-1
(3) Cold start aid indicator	3-1
(4) Tachometer and Hour meter	3-2
(5) Engine coolant temperature gauge	3-2
(6) Fuel level gauge	3-2
(7) Turn signal light switch	3-3
(8) Engine oil pressure indicator	3-3
(9) Battery charging indicator	3-3
(10) Light switch	3-4
(11) Horn switch	3-4
(12) Hazard warning light switch	3-5
(13) Work light switch	3-5
(14) PTO operation indicator	3-6
(15) PTO switch	3-6
(16) Parking brake indicator	3-6

3-2. Operating Levers and Pedals

(1) Throttle lever	3-7
(2) Brake pedal	3-8
(3) Parking brake lever	3-8
(4) Range gear shift lever	3-8
(5) PTO select lever	3-9
(6) 4WD lever	3-9
(7) Differential lock pedal	3-10
(8) HST forward/ reverse pedal (HST type)	3-10
(9) HST neutral switch	3-11
(11) Cruise control lever (HST type)	3-11

3-3. Hydraulic System

(1) Steering system	3-12
(2) Hydraulic lift Control	3-13
(3) Down speed control knob	3-13
(4) Remote control lever and Quick coupler	3-14
(5) Hydraulic System Diagram	3-15

Contents



4. Operation and Work

4-1. Engine start and stop

- (1) Engine start 4-1
- (2) Start in cold weather 4-2
- (3) Engine stop 4-2

4-2. How to Drive and how to Stop

- (1) How to drive 4-3
- (2) Changing speed 4-4
- (3) Emergency Stop 4-4
- (4) Stopping tractor 4-5
- (5) Driving tractor on the road 4-6
- (6) Parking 4-7

4-3. How to handle new tractor

- (1) Check points 4-8
- (2) Notices in handling new Tractor 4-8

4-4. Attaching Implement

- (1) 3-point linkage 4-9
- (2) Upper link installation and adjustment 4-10
- (3) Adjustment of Lift rod's length 4-10
- (4) Adjustment of Stabilizer's length 4-10
- (5) Reference of Implement installation part 4-11
- (6) Reference of PTO shaft 4-11
- (7) Hitch and Drawbar 4-13
- (8) 7-Pole connector (option) 4-14
- (9) Technically maximum permissible mass 4-15
- (10) Adjusting Wheel tracks and tire replacement 4-16
- (11) Tires and Load capacity 4-16
- (12) Adjusting Steering angle 4-17
- (13) Recommended maximum specification of implements 4-18

4-5. Driving Speed 4-19



5. Lubrication and Maintenance

5-1. Checking of Each Part

- (1) Checking Parts 5-1
- (2) Maintenance Table 5-2

Contents

5-2. Lubricants and Capacity	5-3
5-3. Access for maintenance	5-4
5-4. First 50 hour check	5-4
5-5. Checking Before Starting (Daily check)	
(1) Engine oil	5-5
(2) Fuel tank	5-6
(3) Instrument panel & Indicators	5-6
(4) Turn signal lights, Lights, Horn	5-7
(5) Engine coolant	5-7
(6) Air cleaner (Dry type)	5-8
(7) Cleaning of Radiator and Radiator screen	5-9
(8) Tires air pressure and damage	5-9
(9) Tightening state of Bolts and Nuts of each part	5-10
(10) Adjustment of Brake pedal play	5-10
(11) Adjusting HST control linkage (HST type)	5-11
5-6. Every 50 hour check	
(1) Lubricating grease	5-12
(2) Checking Transmission oil	5-12
(3) Checking Front axle oil	5-13
(4) Battery check	5-13
(5) Air cleaner (Dry type)	5-13
(6) Cleaning of Radiator and Radiator screen	5-13
5-7. Every 300 hour check	
(1) Replacing Engine oil and Filter	5-14
(2) Replacing Hydraulic oil Filter	5-15
(3) Replacing Fuel filter cartridge	5-16
(4) Replacing Air cleaner element (Dry type)	5-16
(5) Tension adjustment of Fan belt	5-17
(6) Toe-in	5-17
5-8. Every 600 hour check	
(1) Changing Front axle oil	5-18
(2) Changing Transmission oil	5-18
(3) Replacement of Engine Coolant	5-19
(4) Adjusting Engine Valve clearance	5-20
(5) Checking Nozzle injection pressure	5-20

Contents

5-9. General maintenance (When required)

- (1) Air-bleeding from Fuel system 5-21
- (2) Fuse & Main fuse 5-23
- (3) Battery handling and Notices 5-25

5-10. Troubleshooting 5-29

6. Dimension and Specification 6-1

1. General Notices for Safety

1-1. Before using the tractor



※ **Read this Operator's manual carefully, before using the tractor, to understand fully.**

◆ General information for right use

- Your tractor is designed and manufactured to be **used for agriculture**. Do not use the product for improper purpose out of the intention of manufacturer, and follow the safety instructions provided by this Operator's manual.
- Especially, read Chapter 1 "**General Notices for Safety**" thoroughly and **never modify or change** the driver's protection device or safety device without permission, **never use tractor without safety** devices or operate in violation of traffic rules, etc. (Do not remove seat belt or safety frame (Roll bar) or PTO shield)
- After using first 50hours, perform "**First 50 hour check**" and periodic regular check. (See page 5-4)
- The manufacturer will not be responsible for the damage or safety problems caused by maintenance or repair with non-genuine parts. It must be requested to **use the genuine parts**.
- When cleaning the tractor by using high pressurized water, do not inject water directly to the electronic parts, wiring, air intake pipe, hot engine or muffler inside bonnet.
- Maintenance and repair of the tractor is performed by **skilled technical experts with the proper tools** authorized by the manufacturer.
- For damage or accidents caused by the miss use or operation in violation of these rules, the manufacturer will not have any responsibility and warranty.
- Keep this Operator's manual for future reference at hand (on the tractor).

◆ Safety Mark Description

- In the places where the cautions in usage are required, the marks such as "**DANGER**", "**WARNING**", "**CAUTION**" are found.
- You should comply with the description marked on the decals attached on the product or the contents marked with safety mark in this Operator's Manual..



Danger

Danger – This indicates a fatal dangerous situation that may cause a serious injury or death if not avoided.



Warning

Warning – This indicates a potential dangerous situation that may cause a serious injury or death if not avoided.



Caution

Caution – This indicates a potential dangerous situation that may cause a light injury or damage to the properties if not avoided.

Notice

Notice – This indicates the instructions for right use for the safety of persons or products.

◆ Product Identification

Your tractor has a exclusive chassis number and engine number marked with product serial number tag to identify the product. (See Fig.1-1)

In case of requesting service or parts from your dealer

Dealer will need chassis serial number, engine serial number, and also running hours displayed on the instrument panel. (See Fig. 1-3)

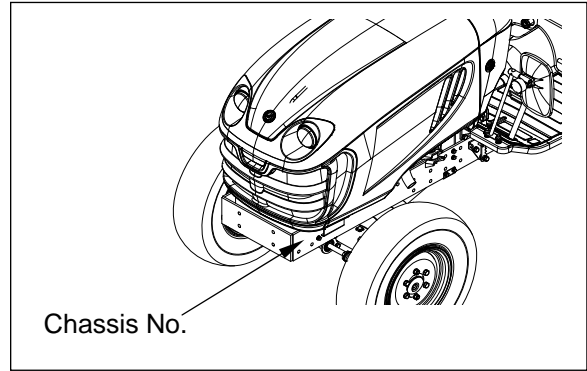

Fig.1-1

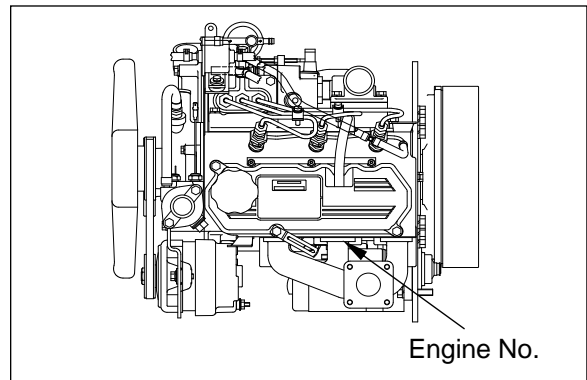

Fig.1-2

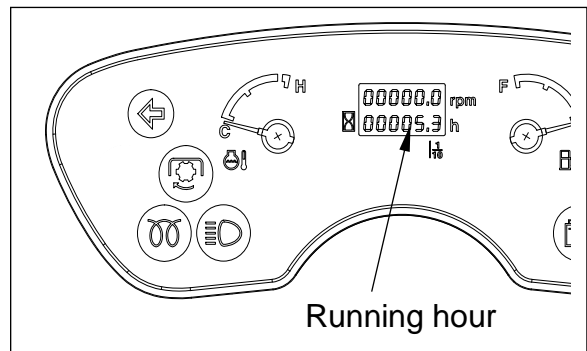
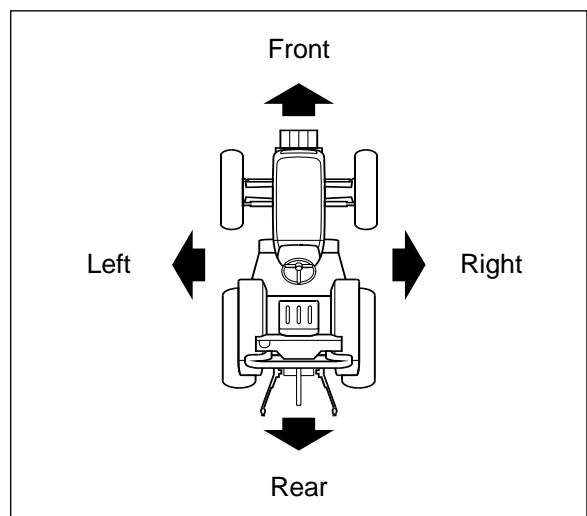

Fig.1-3

◆ Terminology

When reading this Operator's Manual, refer to the right figure for the discrimination of the front/rear/ left/ right direction.



1-2. Safety Precautions - read this for safety before using.

(1) Notices before using

- **For Safety Instruction** : Before using the tractor, read this Operator's Manual carefully and understand the instructions fully for the safety prevention and right usage of the tractor and then use the tractor safely according to the instructions.

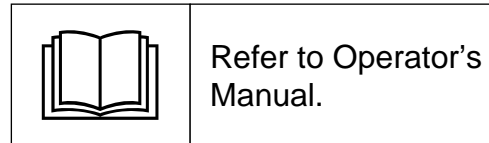

Especially, special cares must be taken for using the tractor in the places where the safety signs such as Danger, Warning, Caution etc. are marked. (For further information, See page 1-1)

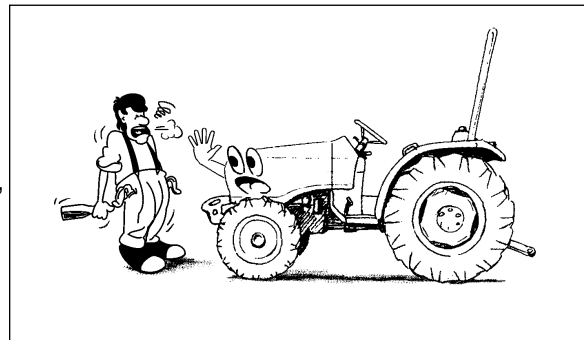

- **Safety Decals** : For right use and personal safety of the operator, the safety decals are attached to the parts related with safety operation. Before using the tractor, comply with the safety instructions. (For further information, refer to "1-6 Safety Decals", See page 1-17)

- **Operator's condition** : The persons such as patients, drunks, people on drugs etc. are never allowed to operate this tractor. Only educated operators can use the tractor after learning the usage of controls for moving, stopping, turning and other operating.

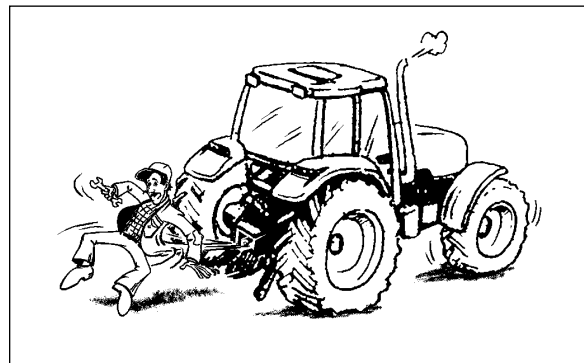

- **Suitable Clothes & Protect Entanglement** : When checking or operating the tractor, wear tight fitting clothes and safety equipment instead of loose or long clothes. Also, slippers, high heel shoes are not suitable for operation. Wear the low shoes or work shoes or boots.



	<p>▶ Do not approach the rotating shaft such as PTO shaft or cooling fan, especially, with loose clothing and long clothes. The entanglement in rotating shaft can cause serious injury or death.</p> <p>▶ Stop the engine and be sure PTO shaft is stopped before getting near it.</p>
	

- **Keep Riders off** : Riders on the tractor or implements obstruct the operator's view and can be thrown off the tractor. It can cause a serious injury or death. Riders should not be carried on the tractor at any time.

	▶ Additional seat (if fitted) is used for driver training or instruction. Do not permit anyone to ride on the tractor.
---	--

- **Protect Children** : Pay special attention to children (or a child) while using the tractor or during storage.
 - Make sure children keep a safe distance from the tractor and all implements before using the tractor. Be alert to the presence of children.
 - Do not let children or an untrained person operate the tractor.
 - Do not allow children to approach the tractor while the engine is running.
 - When parking the tractor, remove the ignition key and lower implements to the ground for children's safety.

 Warning	▶ As children are very curious, they may do unexpected movements or actions. Special care must be taken, when operating tractor or equipment.
---	---

- **Periodical Check** : "Lubrication and Maintenance" must be performed periodically. If necessary, do it immediately and if not, it may cause the failure, reduction of product life or physical injury.

* Periodic Lubrication and Maintenance

Fuel, Oil, Filter, Air cleaner, Battery, Belt, Cable, Grease, Pedals such as clutch and brake pedal, Tire air pressure, Wheel bolts, Toe-in, Electrical wirings, other items related to safety.

- **Genuine Parts** : When replacing parts, you must use "Genuine Parts" of LS tractor. Contact your authorized dealer. If not, it may cause a reduction of product life, failure and serious injury.

- **Restrict Maintenance** : If you repair or change some components and settings arbitrary, the performance of the tractor can NOT be guaranteed and may void the warranty, And also, maintenance of the heavy weighted parts without special tools can cause serious injury. If it is required to check or repair the tractor due to trouble, or if you have any questions for the usage or operation of the tractor, contact your authorized dealer.

* The items that are not allowed to be modified or changed or removed arbitrarily by user are below :

- Protection structures such as PTO cover, Guards, Safety frame (Roll Bar), Cabin, etc.
- Engine components, Fuel injection control and setting, etc.
- Automatic control equipment, Lamps, Transmission, Hydraulic valve and pressure settings.
- Other parts that detail and where complicated adjustments are needed.

 Warning	▶ Skilled professional technology is needed for the repair. ▶ For detail maintenance or repair, contact your authorized dealer.
---	--

- **Lamps** : Do not modify the lamps or change the bulb capacity arbitrarily.

 Warning	▶ Modified lamps or change bulb capacity may cause the traffic accident by disturbing approaching driver's views. ▶ If the lamp is blown out, replace it immediately with a genuine part. In case of driving at night, it may cause a traffic accident.
---	--

- **Safety Structure** : For the safety of the driver, various protection structures are attached on the tractor. If these structures are changed or detached by user arbitrarily, it may cause serious accident. Such behaviors are prohibited strictly.

 Warning	<ul style="list-style-type: none"> ▶ Do not disassemble or drill the Bonnet (Hood), Fan cover, PTO cover, PTO shaft cover, Safety frame (Roll Bar) or Cabin etc. or do not modify other structures by welding arbitrarily. It may cause the loss of original function of the structures and serious injury may occur, and may void warranty. ▶ If the protections or safety devices are broken, replace them immediately. If not, it can cause a accident or serious injury.
--	--

(2) Notices when starting Engine

- Check each part with reference of “5. Lubrication and Maintenance” in this manual. If necessary, repair or replace it immediately. **Especially, check if safety protection structures or covers are attached originally and the bolts are tightened well.**
- Before starting, **check again if there are other workers or children around the tractor and implements and keep a safe distance.**
- Start engine and operate the tractor **after sitting on the driver’s seat** correctly with seat belt fastened.
- Place the shuttle lever, transmission gear lever in NEUTRAL and especially check if parking brake is applied.
- Lower the implements on the ground.
- Ensure that rear view mirrors and the other mirrors (if fitted) are adjusted correctly, and check the operation of the headlights and other lights
- Put PTO switch to “OFF” position. If the PTO switch is “INDEP” or “MANUAL”, the engine can NOT be started. (See Fig.1-4)
- Depress the clutch pedal fully (if fitted). If not, the start safety switch is not contacted enough and the engine can NOT start.

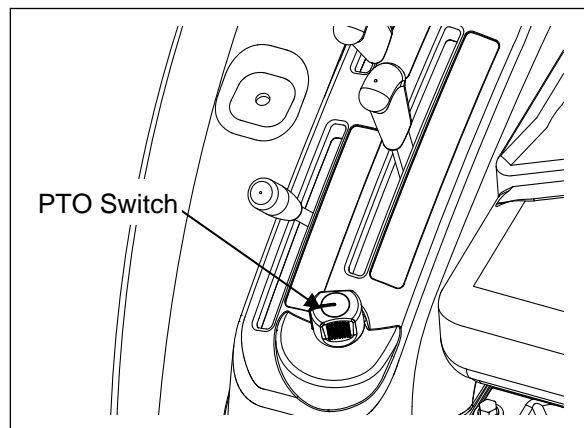
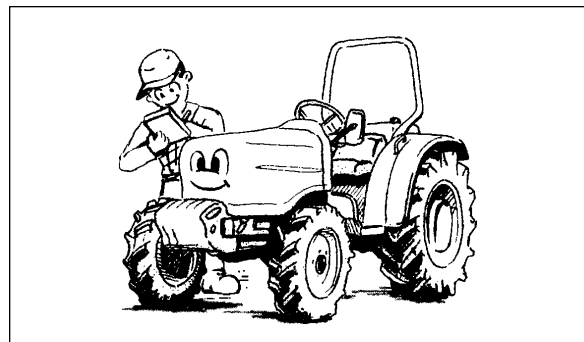





Fig.1-4

 Warning	<ul style="list-style-type: none"> ▶ Do not start the engine in a closed area. The poisonous exhaust gas can cause fatal damage to the driver or persons around.
--	---

(3) Notices while operating/using the tractor

● Ventilation

 Warning	<p>► It is very dangerous to work in a closed area. The poisonous exhaust gas may cause serious damage to the human body. If you should work in this area, make sure to ventilate well and put on the protective mask.</p>
	

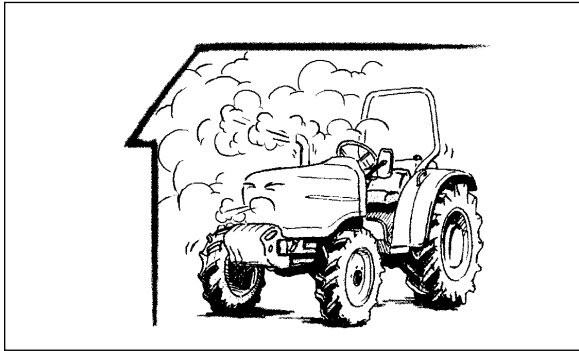

- **Noise and Vibration** : When working between buildings or in confined spaces, the sound pressure level can be increased. Wear suitable ear protectors in high noise level conditions. When working with equipment in the field, Vibration may intensity from the equipment may be increased. To reduce the harm to the body, take a rest periodically.

- Connect left and right brake pedals while driving on the road. (if fitted)
- DO NOT use differential lock device while driving on the road or turning in the field.
- DO NOT ride your foot on the brake pedal or clutch pedal.

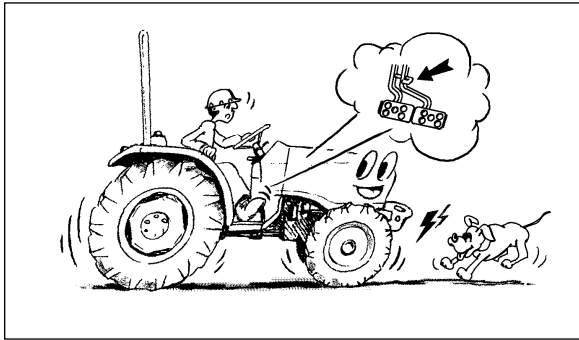

- Lower the driving speed enough before turning a sharp curve. Especially, when you drive the tractor with implements, make the turning radius wider.
- DO NOT start or stop the tractor suddenly. Engage the clutch and brake softly. If not, front wheels can be lifted up and it is very dangerous.
- Do not jump up and down while tractor is moving. When getting off or on the tractor, use the grip or handrail and sub step to prevent falls.

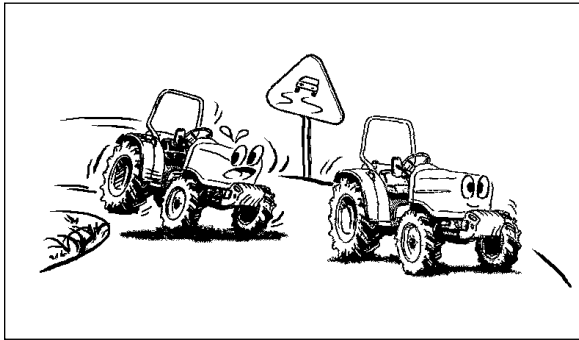

- When driving the tractor in reverse, lower the engine speed. Make sure to check if there is any obstacle or person in the rear.
- DO NOT permit other people and especially children approach within working area while operating tractor and equipment.

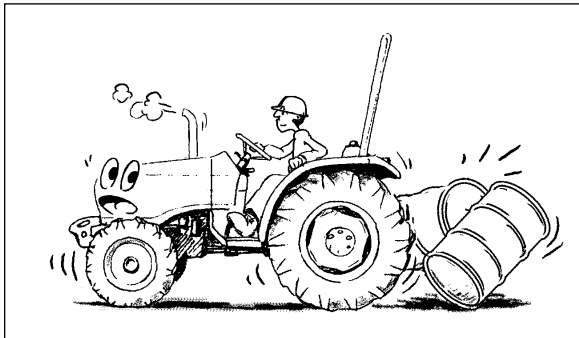

- Obey the traffic rules while driving on public roads. Do not exceed the local legal speed limit. Use a sign beacon or slow moving vehicle (SMV) to indicate that the vehicle is slow moving.
- If you can not drive the tractor due to a failure, move the tractor to a safe place and install troubled vehicle (safety tripod).
(Day : backward 100m (328 ft)
Night : backward 200m (656 ft))

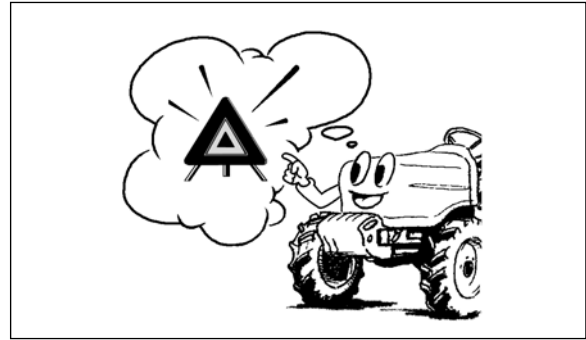

- Do not overuse the fuel, oil, etc and pay attention not to contact the skin directly. Generally, these materials contain harmful materials to the human body. When you work in a area where hazardous chemicals are sprayed, check the cabin filter (if fitted) and replace the filter with suitable one for the purpose being used. To protect the body completely from these harmful materials, wear a safe protection equipment such as mask, and clean the body after working.

- When crossing a high ridge, let down the implement and go straight across the ridge at low speed.
- When connecting the implements to the front/rear of the tractor, install the proper additional weights in the rear/front of the tractor to keep the balance of the tractor.

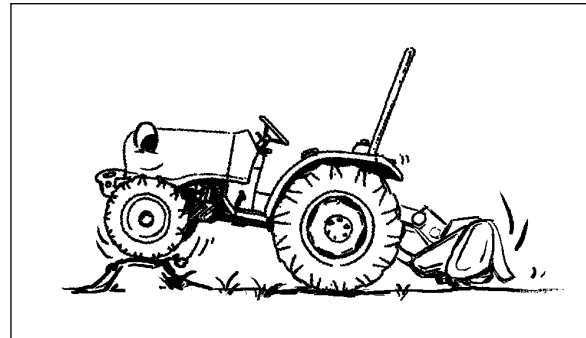

- On a downhill, operate the throttle pedal and brake pedal slowly and DO NOT drive while the transmission gear is in NEUTRAL.
- To climb a steep slope, drive tractor slowly in reverse up the slope rather than forward. It is much safer.
- When turning the tractor on a slope, pay attention to safety especially.

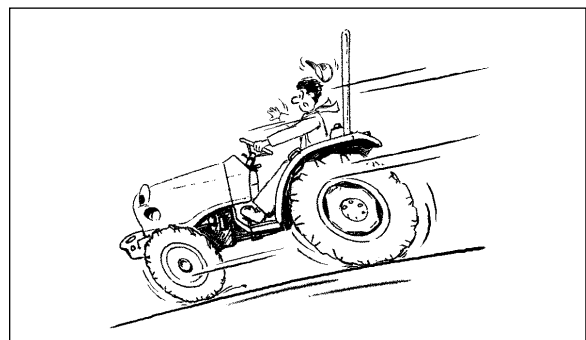

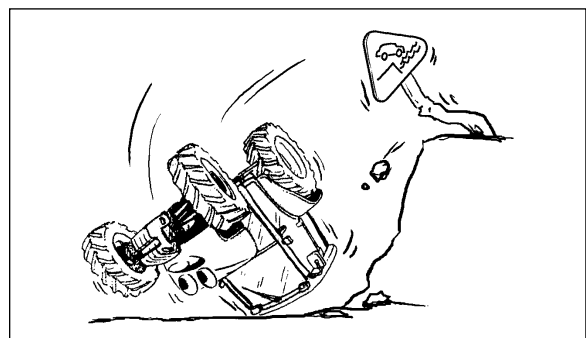

- When working at the edge of steep slope, take special care about a turn-over.
- When working, wear the protection equipment and tighten the seat belt.
- If the authorized passenger seat are not installed, keep riders off.



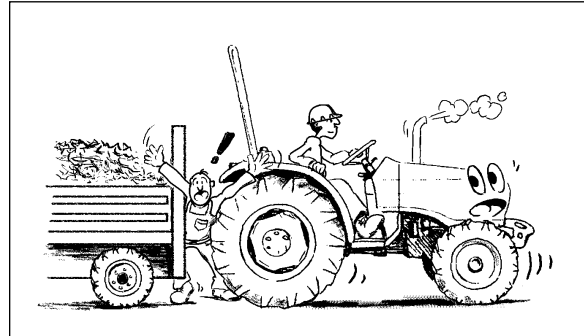

(4) Notices when connecting Implement

- Attach or detach the implement on wide and level ground.
- Do not stand between tractor and implement.
- Use hitch or drawbar for towing. Do not tow by connecting with any other structures.
- When connecting heavy implements, apply the parking brake and use the wheel chock.
- Do not attach over-weighted implement.



 Caution	<ul style="list-style-type: none"> ▶ When connecting or disconnecting hydraulic coupler, lower implement on the ground, turn off engine and check if the pressure of hydraulic line is released. ▶ When installing the implement having big hydraulic cylinders or lines, check oil level in tractor transmission housing after installing the implements.
--	--

 Warning  	<ul style="list-style-type: none"> ▶ Before connecting or checking the implement, put PTO switch to “OFF” and place PTO gear lever in Neutral position. ▶ When attaching or detaching the implement, make sure to fix the implement and tighten the three point hitch pins correctly. If not, the serious troubles and injury can occur during the operation. ▶ If heavy loaded trailer is connected to 3-point linkage or any structure, it can cause turnover or failure and serious injury. Make sure to use towing hitch or authorized draw bar.
--	---

(5) Notices when towing the tractor

- If tractor needs to be towed for a short distance, Use the hitch (or drawbar) or front towing hook. Do not connect to other structures such as rear axle, ROPS, front axle, steering components for towing.
- Tractor can be steered for a short distance without engine running, but it will be hard to turn the steering wheel. If possible, run the engine for steering and lubrication.
- When being towed, disengage the 4WD, differential lock, parking brake and place all gear shift levers in neutral position. Refer to “3-2. Operating levers and pedals”. (See page 3-7)
- Check the horizontal and vertical permissible load of the hitch (or drawbar) before towing. The load is different with trailer brake, and stopping distance increases with speed and weight of towed loads and slope. Make sure you consider the total weight of the equipment and its load. (See page 4-13)

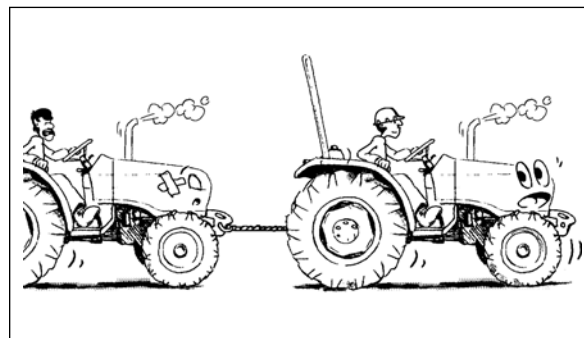

Buy Now



Our support email:

ebooklibonline@outlook.com