

O P E R A T O R ' S M A N U A L

ROTARY TILLERS

RT 1173

RT 1273

RT 2293

RT 1181

RT 2283

RT1173: Serial Number XFRT11X130882 & Above

RT1181: Serial Number XFRT11X130879 & Above

RT1273: Serial Number XFRT12X130422 & Above

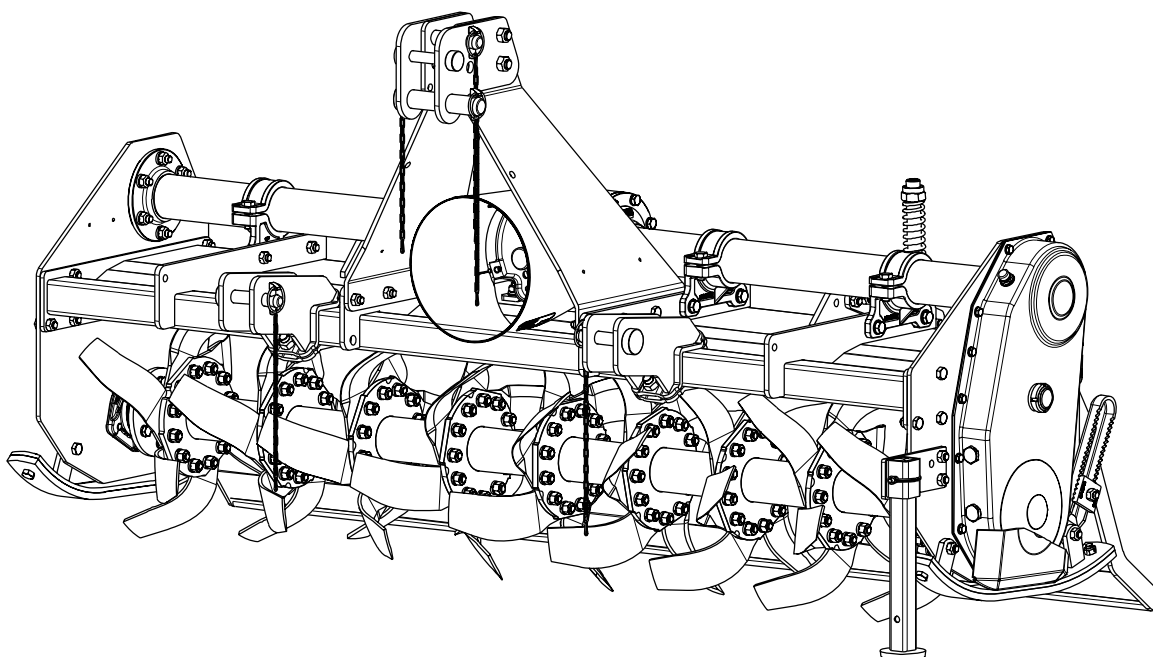

FRONTIER.

Cod. F07011069 / Rev. 00 (2013-06)

THIS MANUAL IS ALSO APPLICABLE TO FRONTIER TILLERS WITH MODEL NUMBERS ENDING IN A 'C'.

TABLE OF CONTENTS

Technical specification		Change speed	19
Technical specification	4	Tilling tips	20
Technical specification - Hitch	6	During tilling	20
		Replacement parts	20
Safety signs		Service Machine Safely	
Safety-Alert symbol	7	Practice safe maintenance	21
Identification machine	7	Wear appropriate clothing	21
Machine safety labels	7	Stay clear of rotating drivelines	21
Machine safety labels and positions		Service lubrication	
Machine safety labels and positions	8	Service lubrication	22
		Every 8 work hours	22
Preparing the vehicle		Every 50 work hours	22
Preparing the tractor	10	Every 400 work hours	22
Park vehicle safety	10	Every 1000 work hours	22
Stay clear of rotating drivelines	10	Greasing and lubricant points	23
		Lubricants	23
Installing		Screw tightening torques	23
Installing tiller on tractor	10	Service	
PTO shaft	12	Service intervals	24
PTO shaft with clutch	13	Replacing tines	24
Quick Coupler (optional)	14	Tines	24
Park vehicle safety	14		
Stay clear of rotating drivelines	14	Troubleshooting	
		Using troubleshooting chart	25
Removing		Storing machine	
Removing tiller	15	Storing tiller	26
Removing tiller with Quick Coupler	15	Removing tiller from storage	26
Operating		Assembly / Spare parts	
Operate safely	16	RT 1173-1181	28
Wear appropriate clothing	17	RT 2283-2293	30
Stay clear of rotating drivelines	17	Lift hook assembly procedure	32
Raising parking stand	17	Installing driveline on tiller	32
Lowering parking stand	17	Spare parts	32
Levelling attachments (side-to-side)	17		
Levelling tiller (front-to-rear)	18		
Adjusting skid shoes	18		
Adjusting levelling board	18		
Spring ram	19		

TO THE DEALER:

Assembly and proper installation of this product is the responsibility of the Frontier dealer. Read manual instruction and safety rules. Make sure all items on the Dealer's Pre-Delivery Check List in the Operator's Manual are completed before releasing equipment to the owner.

The dealer must complete the Warranty Registration, located on the Frontier website. **Warranty claims will be denied if the Warranty Registration has not been completed.**

TO THE OWNER:

Read this manual before operating your frontier equipment. The information presented will prepare you to do a better and a safer job. Keep this manual handy for ready reference. Require all operators to read this manual carefully and become acquainted with all the adjustment and operating procedures before attempting to operate. Replacement manuals can be obtained from your selling dealer.

The equipment you have purchased has been carefully engineered and manufactured to provide dependable and satisfactory use. Like all mechanical products, it will require cleaning and upkeep. Lubricate the unit as specified. Observe all safety information in this manual and safety decals on the equipment.

For service, your authorized Frontier dealer has trained mechanics, genuine Frontier service parts, and the necessary tools and equipment to handle all your needs.

Use only genuine Frontier service parts. Substitute parts will void the warranty and may not meet standards required for safe and satisfactory operation. Record the model number and serial number of your equipment in the spaces provided:

Model: _____

Date of Purchase _____

Serial Number: (see Safety Decal section for location) _____

Provide this information to your dealer to obtain correct repair parts.

Throughout this manual, the term **IMPORTANT** is used to indicate that failure to observe can cause damage to equipment. The terms **CAUTION**, **WARNING** and **DANGER** are used in conjunction with the Safety-Alert Symbol, (a triangle with an exclamation mark), to indicate the degree of hazard for items of personal safety.



This Safety-Alert Symbol indicates a hazard and means **ATTENTION! BECOME ALERT! YOUR SAFETY IS INVOLVED!**



Indicates an imminently hazardous situation that, if not avoided, will result in death or serious injury.



Indicates a potentially hazardous situation that, if not avoided, could result in death or serious injury, and includes hazards that are exposed when guards are removed.



Indicates a potentially hazardous situation that, if not avoided, may result in minor or moderate injury.

IMPORTANT

Indicates that a failure to observe can cause damage to equipment.

NOTE

Indicates helpful information.

TECHNICAL SPECIFICATIONS

RT 1173 - 1181



RT 1273

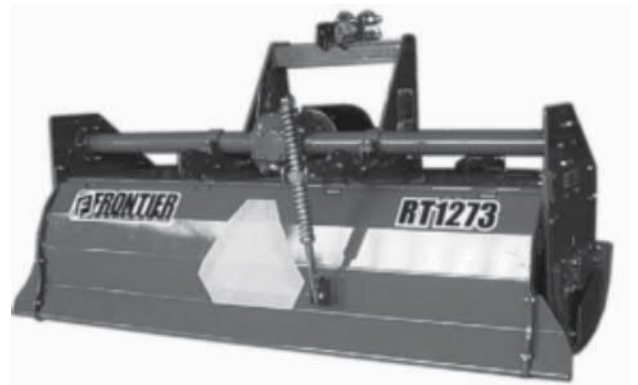

RT 2283 - 2293

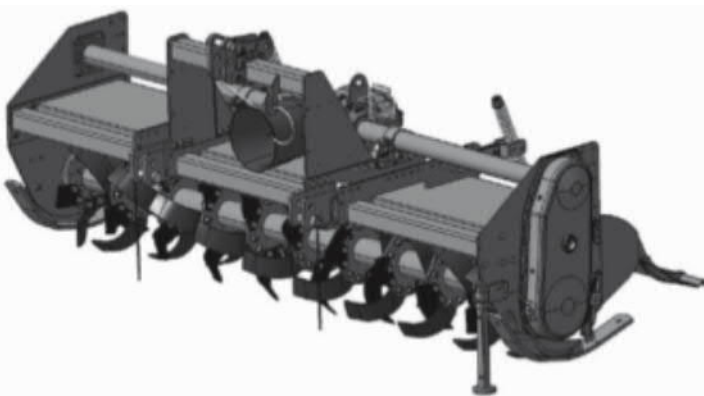

TECHNICAL SPECIFICATIONS

RT 1173 - 1181

<i>Model</i>	<i>Work/width inches</i>	<i>Tractor HP min</i>	<i>Tractor HP max</i>	<i>Weight lbs.</i>	<i>Side Drive</i>	<i>PTO shaft</i>	<i>Speeds gear box</i>	<i>Input speed</i>	<i>Hitch</i>	<i>Tines STD</i>	<i>Rotor blades</i>	<i>Rotor flanges</i>
RT 1173	73	45	60	761	Gear	Slip Clutch	Single	540	Cat. "II" Quick coupler	"C"	6	10
RT 1181	81	50	60	810	Gear	Slip Clutch	Single	540	Cat. "II" Quick coupler	"C"	6	11

RT 1273

<i>Model</i>	<i>Work/width inches</i>	<i>Tractor HP min</i>	<i>Tractor HP max</i>	<i>Weight lbs.</i>	<i>Side Drive</i>	<i>PTO shaft</i>	<i>Speeds gear box</i>	<i>Input speed</i>	<i>Hitch</i>	<i>Tines STD</i>	<i>Rotor blades</i>	<i>Rotor flanges</i>
RT 1273	73	30-70	80	968	Gear	Slip Clutch	Single	540	Cat. "II" Quick coupler	"L"	6	7

RT 2283 - 2293

<i>Model</i>	<i>Work/width inches</i>	<i>Tractor HP min</i>	<i>Tractor HP max</i>	<i>Weight lbs.</i>	<i>Side Drive</i>	<i>PTO shaft</i>	<i>Speeds gear box</i>	<i>Input speed</i>	<i>Hitch</i>	<i>Tines STD</i>	<i>Rotor blades</i>	<i>Rotor flanges</i>
RT 2283	83	30-70	80	1397	Gear	Slip Clutch	Multi	540	Cat. "II" Quick coupler	"L"	6	8
RT 2293	93	40-80	100	1496	Gear	Slip Clutch	Multi	540	Cat. "II" Quick coupler	"L"	6	9

Thank you so much for reading.
Please click the “Buy Now!”
button below to download the
complete manual.



After you pay.

You can download the most
perfect and complete manual in
the world immediately.

Our support email:

ebooklibonline@outlook.com