

Quantum 65C
Quantum 75C
Quantum 85C
Quantum 95C

Operator's Manual

Print No. 84131288

3rd edition

English 09/08



Quantum 65C
Quantum 75C
Quantum 85C
Quantum 95C

Operator's Manual

Print No. 84131288

3rd edition

English 09/08



SECTION SUMMARY

- 1 - Introduction and safety measures**
- 2 - General Information, Controls and Instruments**
- 3 - Field operation**
- 4 - Lubrication and Maintenance**
- 5 - Troubleshooting**
- 6 - Vehicle storage**
- 7 - Accessories**
- 8 - Specifications and Data**
- 9 - Running-in period**
- 10 - Alphabetical Index**

Electro-magnetic Interference (EMC)

This tractor complies strictly with the European Regulations on electro-magnetic emissions.

However, interference may arise as a result of add-on equipment which may not necessarily meet the required standards.

As such interference can result in serious malfunction of the unit and/or create unsafe situations, you must observe the following:

- Ensure that each piece of non-CASE IH equipment fitted to the tractor bears the CE mark.



- The maximum power of emission equipment (radio, telephones, etc.) must not exceed the limits imposed by the national authorities of the country where you use the tractor.
- The electro-magnetic field generated by the add-on system should not exceed 24 V/m at any time and at any location in the proximity of electronic components.

Failure to comply with these rules will render the CASE IH warranty null and void.

CONTENTS

Section - Page

SECTION 1

Communications for the user	1-1
Identification plates	1-2
Important ecological considerations	1-5
Always work safely	1-6
Working safely	1-7
Guards and safety covers	1-13
Safety decals	1-15
Standard symbols	1-27
Tractor noise level information sheet	1-28

SECTION 2

General notes, controls and instruments	2-1
Analog control panel	2-2
Digital instrument control panel	2-7
Multifunction display	2-13
Light control lever	2-30
Operating controls	2-31
Cab	2-41
Mechanical transmission (16F+16R) 18.64/24.35 mph (30/40 km/h)	2-57
Electrohydraulic transmission (16F+16R) 18.64/24.35 mph (30/40 km/h)	2-58
Mechanical transmission (28F+16R) 18.64/24.35 mph (30/40 km/h)	2-61
Mechanical transmission (32F+16R) 18.64/24.35 mph (30/40 km/h)	2-63
Electrohydraulic transmission (32F+16R) 18.64/24.35 mph (30/40 km/h)	2-65
Transmission with electrohydraulic clutch 18.64/24.35 mph (30/40 km/h)	2-71
Fast transmissions 24.35 mph (40 km/h)	2-74

SECTION 3

Field operation	3-1
Starting and stopping	3-2
Brakes	3-6
Mechanical 4WD	3-8
Electrohydraulically controlled four-wheel drive	3-9
Differential lock	3-10
Lim-Slip front differential lock	3-11
Electrohydraulic differential lock	3-12
Power Take- Off	3-14
Hydraulic lift with mechanical control	3-19
Electronically controlled hydraulic lift	3-23
Rear three-point linkage	3-31
Implement linkage points	3-34
Rear remote auxiliary control valves	3-39
Front 2 WD wheel track adjustment	3-42
4WD wheel track adjustment	3-44
Tyres	3-50
Metal ballast	3-65
Liquid ballasting	3-66
Permitted maximum weights	3-69

SECTION 4

Lubrication and maintenance	4-1
Running in period	4-2
Fuelling the tractor	4-3
Access for inspection and maintenance	4-7
Lubrication and maintenance table	4-8
Flexible maintenance	4-11
Instrument panel warning lights	4-8
EVERY 10 HOURS OF WORK	4-20
EVERY 50 HOURS OF WORK	4-21
EVERY 100 HOURS OF WORK	4-24
EVERY 300 HOURS OF WORK	4-27
EVERY 600 HOURS OF WORK	4-32
EVERY 1200 HOURS OR EVERY YEAR	4-36
EVERY 1200 HOURS OF WORK OR EVERY 2 YEARS	4-38
EVERY 1800 HOURS OF WORK	4-44
Electrical System	4-45
Fuelling	4-78

SECTION 5

Troubleshooting, causes and solutions	5-1
---	-----

SECTION 6

Storing the tractor	6-1
---------------------------	-----

SECTION 7

Accessories	7-1
Front Power Take Off	7-2
Mechanically controlled front hydraulic lift	7-4
Electronically controlled front hydraulic lift	7-5
Front three-point linkage	7-12
Quick fit implement linkage	7-14
Towing equipment	7-16
Hydraulically operated towing hitch	7-19
Joystick	7-22
Control valve for trailer hydraulic brakes	7-23

SECTION 8

Specifications and data	8-1
-------------------------------	-----

SECTION 9

Inspections and/or operations to be carried out	9-1
---	-----

SECTION 10

Alphabetical index	10-1
--------------------------	------

SECTION 1

GENERAL INFORMATION AND SAFETY PRECAUTIONS

GENERAL

This Use and Maintenance Manual provides a guide for the user with regard to running-in, use and maintenance of the tractor.

Read this manual carefully and keep in a convenient place for future reference. Do not hesitate to contact your local dealer for any queries concerning your tractor. The dealer can provide skilled personnel, trained by the manufacturer, original service parts and all tools and equipment necessary for your service requirements.

The tractor is designed as a power generator and drive-propulsion unit for use in normal and traditional agricultural conditions.

The tractor is also designed to provide maximum performance, economic running and easy use over a wide range of operations. Prior to delivery, all machines are carefully inspected (by both the Manufacturer and your local authorised dealer), to make sure that they reach the user in perfect condition. To maintain the tractor in this condition and ensure trouble-free operation, the routine maintenance described in Section 3 of this manual must be carried out at the specified intervals.

CLEANING THE TRACTOR

Your tractor is an advanced machine, fitted with an electro-hydraulic control system. Care must be taken when cleaning the tractor, especially if a pressurised water cleaner is used.

- When using a pressure washer, never stand too close to the tractor or direct the water jet on electrical components, seals or intake openings, etc..
- Never direct jets of cold water at the hot engine or exhaust. See also Section 4 (Recommendations for bodywork maintenance).

SAFETY PRECAUTIONS

Safety precautions for the operator and bystanders are shown on page vii to xii inclusive. Read the safety instructions and follow recommendations and hints **before** starting to use the tractor.

SERVICE AFTER THE FIRST 50 HOURS OF WORK

The operations required for the first service are shown at the end of the Manual, immediately prior to the index.

After the first 50 hours of use, return to the dealer with your tractor and this Manual in order to carry out the Manufacturer's checks and to fill in the certificates included on pages 9-1 and 9-3). The first sheet (page 9-1) must be compiled on completion of the service and held by the dealer. The second sheet (page 9-3) must be kept in the Manual for documentation and reference purposes. **Check that both copies are signed by both yourself and the dealer.**

SPARE PARTS

"Non-original" spare parts have not been tested or authorised by the Manufacturer. Installation and/or use of such products may adversely affect the tractor's design specifications, thereby compromising operational safety. The manufacturer cannot be held responsible for any damage resulting from the use of "non-original" spare parts. No modifications may be made to the tractor without written authorisation from the Manufacturer.

WARRANTY

The tractor is guaranteed in accordance with current legislation in your country and in line with contractual agreements reached with the dealer at the time of sale. However, the warranty is no longer valid if the rules and instructions for the use and maintenance of the tractor, described in this Manual, are not observed.

TRACTOR IDENTIFICATION PLATES

Serial numbers identify the tractor and its main components. The identification data must be supplied by the dealer for requests for spare parts or service operations. Identification data is of fundamental importance in the event of theft of the tractor. The location of the various identification data is shown below.

TRACTOR CHASSIS FRAME IDENTIFICATION DATA PLATE - Fig. 1

The tractor's frame number is stamped over the front support (1).

Indicate below the corresponding serial number.

No.

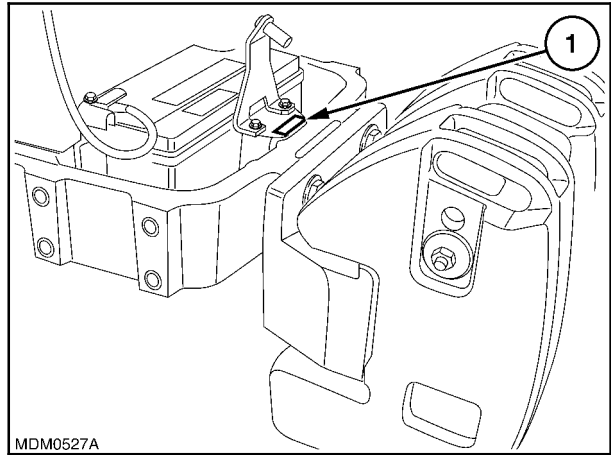

1

TRACTOR TYPE-APPROVAL SUMMARY DATA PLATE FOR MODELS WITH ROLL BAR - Fig. 2

The plate (1) is on the right-hand side.

Indicate below the corresponding serial number.

No.

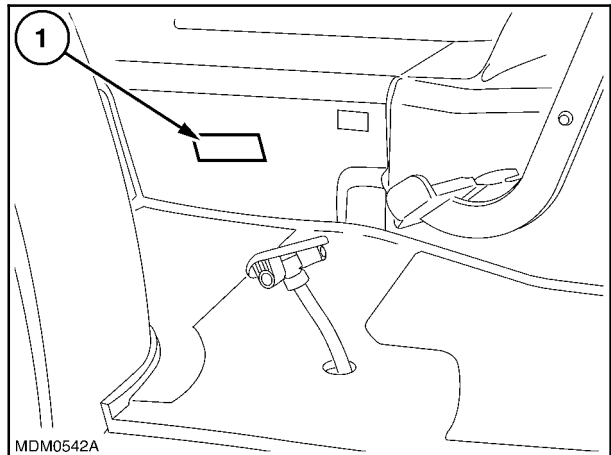

2

TRACTOR TYPE-APPROVAL SUMMARY DATA PLATE FOR MODELS WITH CAB

The plate (1) is inside the cab on the right-hand side.

Indicate below the corresponding serial number.

No.

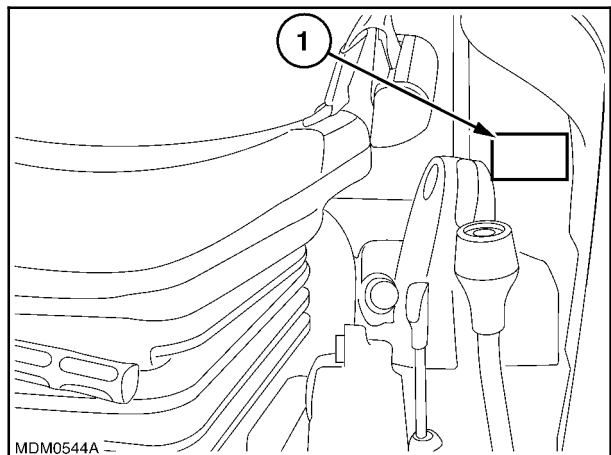

3

**ENGINE IDENTIFICATION DATA PLATE
(MODELS 85C AND 95C) - Fig. 4**

The serial number of the engine fitted on the tractor is stamped on the right-hand side of the engine body (1).

Indicate below the corresponding serial number.

No.

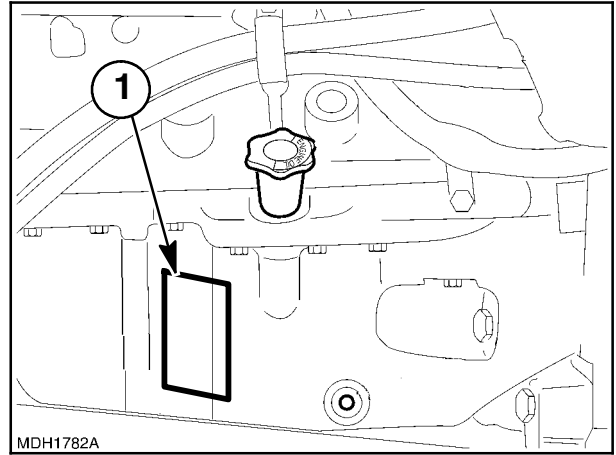

4

**ENGINE IDENTIFICATION DATA PLATE
(MODELS 65C AND 75C) - Fig. 4**

The serial number of the engine installed on the tractor is stamped on the left side of the engine block near the hydraulic pumps (1).

Indicate below the corresponding serial number.

No.

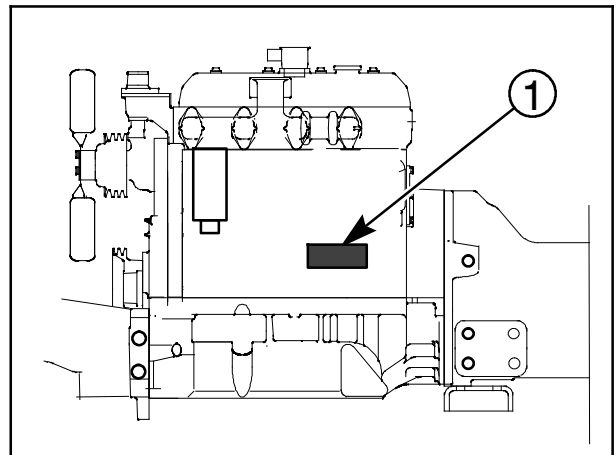

5

ROLL BAR IDENTIFICATION PLATE - Fig. 6

The plate (1) is inside the right-hand upright of the frame.

Indicate below the corresponding serial number.

No.

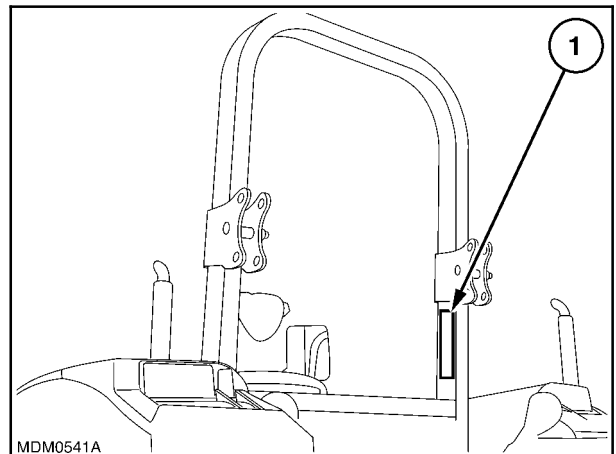

6

CAB IDENTIFICATION PLATE - Fig. 7

The cab identification plate (1) is located at the rear on the right-hand side as shown in the figure.

Indicate below the corresponding serial number.

No.

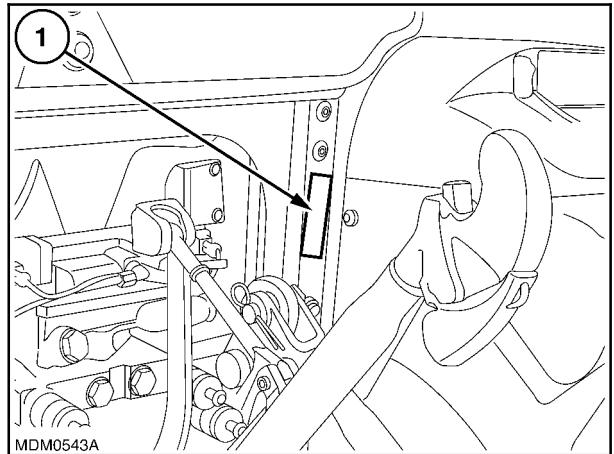

7

FRONT AXLE IDENTIFICATION PLATE - Fig. 8

The plate (1) is located on the right-hand side and gives the identification data for the axle fitted on the machine.

Indicate below the corresponding serial number.

No.

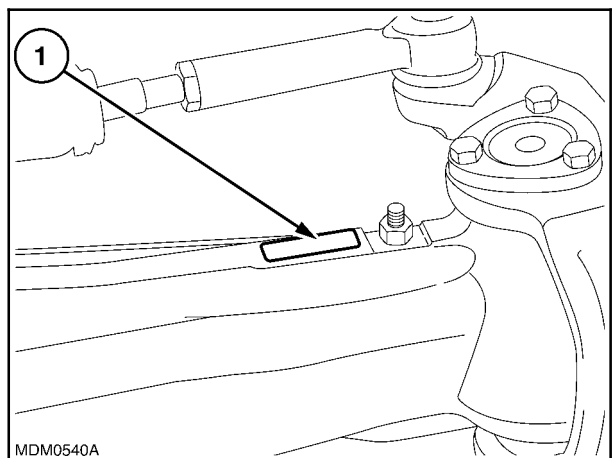

8

TRACTOR CHASSIS FRAME IDENTIFICATION DATA PLATE FOR MODELS WITH FRONT LIFT - Fig. 9

The tractor's frame number is stamped over the front support (1). It gives the identification data.

Indicate below the corresponding serial number.

No.

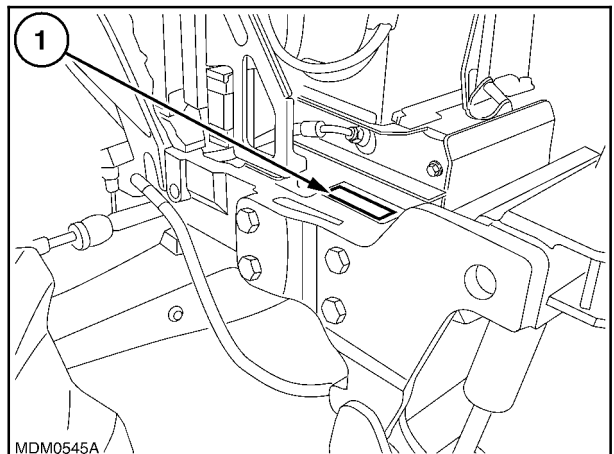

9

IMPORTANT ECOLOGICAL CONSIDERATIONS

Soil, air and water are essential elements for agriculture and for life on in general. If local legislation does not control the treatment of certain substances, the production of which is necessitated by advanced technologies, products derived from chemical and petrochemical products must be used and disposed of according to the rules of common sense.

The following recommendations may be of help:

- Find out what the relevant legislation in your country stipulates.
- Ask your suppliers of lubricants, oils, fuels, anti-freeze, detergents, etc.. for information on the effects of these products on humans and the environment and for instructions concerning their use, storage and disposal. In many cases, local agricultural consultants will be able to provide assistance.

SUGGESTIONS

1. Avoid using unsuitable, pressurised filling systems or fuel cans when filling tanks, as these may cause considerable spillage and leakage of liquids.
2. As a general rule, do not allow liquid fuels, lubricants, acids, solvents, etc., to come into contact with the skin. The majority of these products contain substances that are potential health hazards.
3. Modern lubricants contain additives. Do not burn contaminated fuel oils and/or oils used in conventional heating systems.
4. Avoid spillage when transferring used engine cooling liquids, engine and transmission lubricants, hydraulic oils, brake fluids, etc.. Never mix used brake oil with fuel oil, or fuel oil with lubricants. Store safely until suitable disposal can be arranged according to national legislation or local regulations.
5. Modern anti-freeze liquids and solutions, e.g. anti-freeze and other additives, must be replaced every two years. They must not be left to be absorbed into the ground, but must be collected and disposed of in a suitable manner.
6. Do not open the air conditioning systems to carry out work. These systems contain gas which must not be released into the atmosphere. Contact your dealer or specialised personnel, who are equipped with the appropriate equipment and are authorised to refill the system.
7. Any leakage or defect in the engine cooling or hydraulic systems must be repaired immediately.
8. Do not increase the pressure in pressurised systems, as this may cause component parts to burst.
9. When welding, make sure that hoses are properly protected as sparks or molten material may puncture or weaken the tubes and sleeves, resulting in leakage of oil, cooling liquid, etc..
10. Do not adjust the setting of the fuel delivery system as this will alter the emission of exhaust fumes.

NOTE: THE ENGINES INSTALLED ON THE TRACTORS COMPLY WITH ANTI-POLLUTION LEGISLATION.

Buy Now



Our support email:

ebooklibonline@outlook.com