

NEW HOLLAND

T6020

T6030

T6040

T6050

T6060

T6070

**Elite
Models**

84146400 8/08
Replaces 87654978

OPERATOR'S MANUAL

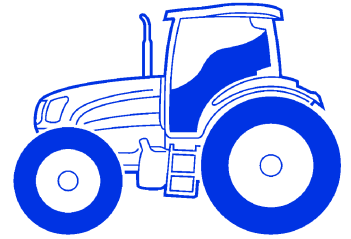

TO THE OWNER

This manual contains information concerning the adjustment and maintenance of your New Holland T6020, T6030, T6040, T6050, T6060, T6070 Elite Tractor. You have purchased a dependable machine, but only by proper care and operation can you expect to receive the performance and long service built into this tractor. Please have all operators read this manual carefully and keep it available for ready reference.

This machine was designed to power and propel itself. It is intended to load and move materials with a variety of buckets and forks. Allied attachments built and supplied by other manufacturers can be used on the tractor where recommended and approved by New Holland.

Your New Holland dealer will instruct you in the general operation of your tractor. (Refer to the "Delivery Report" at the back of this manual.) Your dealer's staff of factory-trained service technicians will be glad to answer any questions that may arise regarding the operation of your tractor.

Your New Holland dealer carries a complete line of genuine CNH Original service parts. These parts are manufactured and carefully inspected to insure high quality and accurate fitting of any necessary replacement parts. Be prepared to give your dealer the model and PIN number of the engine and tractor, when ordering parts. Locate these numbers now and record them below. Refer to the "General Information" section of this manual for the location of the model and PIN numbers of your tractor.

Model _____ Engine Model _____

PIN Number _____ Engine Serial Number _____

IMPROVEMENTS

CNH America LLC is continually striving to improve its products. We reserve the right to make improvements or changes when it becomes practical and possible to do so, without incurring any obligation to make changes or additions to the equipment sold previously.

CONTENTS

Section 0

To the Owner	0-1
Improvements	0-1
Federal Emissions Warranty	0-5
California Emission Control Warranty Statement	0-6

Section 1

General Information and Safety	1-1
Product Identification	1-2
Transporting Towed Equipment at Safe Speeds	1-4
Ecology and the Environment	1-5
Precautionary Statements	1-6
Personal Safety	1-6
Machine Safety	1-6
Information	1-6
Fire or Explosion Prevention	1-7
Fire Prevention – Engine Area	1-8
Safety Precautions	1-9
Operator Protective Structure	1-15
International Symbols	1-22
Airborne Noise Emission	1-23

Section 2

Controls, Instruments, and Operation	2-1
Cab and Platform Controls	2-2
Switch Panels	2-4
Cab	2-6
Electrical Power Connectors	2-18
Seats	2-21
Hand Brake, Throttle and Foot Pedals	2-25
Instrument Console	2-27
Gauges	2-30
Liquid Crystal Displays	2-34

Section 2 (continued)

Dot Matrix Display	2-37
Enhanced Keypad and Performance Monitor (Where Fitted)	2-48
Transmission Operation	2-56
Differential Lock	2-74
Four Wheel Drive	2-76
Terraglide™ Front Axle Suspension (Where Fitted)	2-78

Section 3

Field Operation	3-1
Jumpstarting the Tractor	3-6
Starting the Engine	3-7
Custom Headland Management (Where Fitted)	3-14
Fast Steer (Where Fitted)	3-24
Rear Power Take-off	3-26
Electronic Draft Control	3-35
Hydraulic Remote Control Valves	3-46
Electro-hydraulic Remote Control Valves	3-55
Additional Oil Supply For Remote Hydraulic Services (Power Beyond Port, Where Fitted)	3-67
Three-point Hitch	3-70
Drawbars and Towed Equipment	3-76
Equipment Mounting Points	3-80
Front Wheels	3-81
Dynamic Front Fenders (Where Fitted)	3-85
Rear Wheels	3-86
Ballasting and Tires	3-92

Section 4

Lubrication and Maintenance	4-1
General Information	4-1
Guards	4-7
Lubricants and Coolants	4-10
Lubricant and Coolant Specification	4-11
Lubrication and Maintenance Chart	4-12
When the Warning Symbol Appears	4-14
Every 10 Hours or Daily (Whichever Comes First)	4-18

Section 4 (continued)

Every 50 Hours Carry Out the Preceding Checks Plus the Following 4-20

Every 100 Hours Carry Out the Following Checks 4-30

Every 300 Hours Carry Out the Preceding Checks Plus the Following 4-31

Every 600 Hours Carry Out the Preceding Checks Plus the Following 4-34

Every 1200 Hours or 12 Months (Whichever Occurs First) Carry Out the
Preceding Checks Plus the Following 4-42

Every 1200 Hours or 2 Years (Whichever Occurs First) Carry Out the
Preceding Checks Plus the Following 4-48

Every 3 Years Carry Out the Following 4-53

General Maintenance (To Be Performed As and When Required) 4-54

Section 5

Troubleshooting 5-1

 Engine 5-2

 Transmission – Electro Command 5-5

 Hydraulics 5-6

 Three-point Linkage 5-7

 Brakes 5-8

 Cab 5-8

 Electrical System 5-9

Section 6

Accessories 6-1

Section 7

Tractor Specifications 7-1

General Dimensions – T6020, T6040, T6060 7-2

General Dimensions – T6030, T6050, T6070 7-6

Minimum Hardware Tightening Torques 7-19

Metric Hardware and Locknuts 7-20

Section 8

Check and Adjust, As Required 8-1

Section 9

Index 9-1

FEDERAL EMISSIONS WARRANTY

(North America Only)

(California owner's emissions warranty is covered elsewhere)

CNH UK Ltd warrants that your new 1996 and later heavy-duty off-road diesel engine was designed, built, and equipped to conform to applicable U.S. Environmental Protection Agency regulations for a period of use of five years or 3,000 hours of operation, whichever occurs first.

The new model year, class of diesel engine, and emission application determination for your engine are identified on the emission control information label affixed to the engine. The warranty period begins on the date the new equipment is sold to the first retail purchaser.

Any emission control system parts which are proven defective during normal use will be repaired or replaced during the warranty period. The warranty repairs and service will be performed by any authorized CNH dealer at the dealer's place of business, with no charge for parts or labor (including diagnosis).

As the engine owner, you are responsible to perform all the required maintenance listed in your owner's manual. CNH UK Ltd will not deny an emission warranty claim solely because you have no record of maintenance; however, a claim may be denied if your failure to perform maintenance resulted in the failure of a warranted part. Receipts covering regular maintenance should be retained in the event of questions and these receipts should be passed on to each subsequent owner of the engine.

It is recommended replacement parts used for maintenance or repairs be CNH Service Parts to maintain the quality originally designed into your emission certified engine. The use of non-CNH parts does not invalidate the warranty on other components unless the use of such parts causes damage to warranted parts.

CNH UK Ltd wishes to assure the emission control systems warranty is being properly administered. If you believe you have not received the service entitled to under this warranty, you should contact the nearest CNH Office for assistance. The address and phone number of each Office is in your equipment owner's manual. If additional assistance or information is needed, contact:

Service Department
CNH America, LLC
500 Diller Avenue
New Holland, PA 17557
(717) 355-1121

Please note that the Emission Warranty does not cover:

1. Systems and parts that were not first installed on the new equipment or engine as original equipment by CNH UK Ltd.
2. Part malfunctions caused by abuse, misuse, improper adjustment, modification, alteration, tampering, disconnection, improper or inadequate maintenance, or use of non-recommended fuels and lubricating oils.
3. Accident caused damage, acts of nature, or other events beyond CNH UK Ltd's control.
4. Replacement of expendable items made in connection with scheduled maintenance.
5. Parts requiring replacement, inspection or adjustment maintenance intervals for reasons other than being defective.
6. Parts which are not CNH Service Parts.
7. Loss of time, inconvenience, loss of use of equipment/engine or commercial loss.
8. Equipment with altered or disconnected hourmeter where the hours cannot be determined.
9. Equipment normally operated outside the United States.
10. Non-defective parts replaced by other than CNH dealers.

Coverage

This emission control system warranty applies only to the following emission control parts.

Electronic Control Unit
Fuel Injection Pump
Fuel Injectors
Turbocharger
Intake Manifold
Exhaust Manifold
Boost Pressure Tubing-connection to Aneroid Device ON F.I.P.

CALIFORNIA EMISSION CONTROL WARRANTY STATEMENT

(North America Only)

(California Only)

Your Warranty Rights and Obligations

The California Air Resources Board and CNH UK LTD are pleased to explain the emission control system warranty on your engine. In California, new 2004 and later heavy-duty off-road engines from 50 to 750 HP must be designed, built and equipped to meet the State's stringent anti-smog standards. CNH UK LTD must warrant the emission control system on your engine for the periods of time listed below, provided there has been no abuse, neglect or improper maintenance of your engine.

Your emission control system includes parts such as the fuel injection system and the air induction system.

Where a warrantable condition exists, CNH UK LTD will repair your heavy-duty off-road engine at no cost to you including diagnosis, parts and labor.

Manufacturer's Warranty Coverage:

The 2004 and later heavy-duty off-road engines are warranted from the original date of delivery for five years or 3000 hours of operation, whichever occurs first. If any emission-related part on your engine is defective, the part will be repaired or replaced by CNH UK LTD.

Owner's Warranty Responsibilities:

- As the heavy-duty off-road engine owner, you are responsible for the performance of the required maintenance listed in your owner's manual. CNH UK LTD recommends that you retain all receipts covering maintenance on your heavy-duty off-road engine, but CNH UK LTD cannot deny warranty solely for the lack of receipts or for your failure to ensure the performance of all scheduled maintenance.
- As the heavy-duty off-road engine owner, you should, however, be aware that CNH UK LTD may deny you warranty coverage if your heavy-duty off-road engine or a part has failed due to abuse, neglect, improper maintenance or unapproved modifications.
- Your engine is designed to operate on commercially available diesel fuel only. Use of any other fuel may result in your engine no longer operating in compliance with California's emissions requirements.
- You are responsible for initiating the warranty process. The ARB suggests that you present your heavy-duty off-road engine to a CNH dealer as soon as a problem exists. The warranty repairs should be completed by the dealer as expeditiously as possible.
- If you have any questions regarding your warranty rights and responsibilities, you should contact your nearest CNH Office at the address and telephone number listed on the Owner Assistance page of your equipment's operator manual.
- Prior to the expiration of the warranty, you must give notice of any failure of an emission control warranted part. Such notice must be given to CNH UK LTD or an authorized CNH dealer, and you must deliver the engine to the repair location.
- You, the owner, are responsible for incidental costs incurred by yourself or your employees as a result of an unwarrantable failure. Examples of such costs are communication expenses, meals and lodging.
- The owner is responsible for any business costs or losses, any "downtime" expenses and any "cargo" damage which result from the failure of a warranted part. CNH UK LTD is not responsible for other incidental or consequential damages, including, but not limited to fines, theft, vandalism or collisions.

Parts covered:

This emission control system warranty applies to the following emission control parts:

Electronic Control Unit	Intake Manifold
Fuel Injection Pump	Charge Air Cooler
Fuel Injectors	Exhaust Manifold
Turbocharger	Boost Pressure Tubing (connection to Aneroid Device on F.I.P.)

Any replacement part, equivalent in performance and durability, may be used in the performance of any maintenance or repairs and must be provided without charge to the owner. The use of these parts does not reduce the warranty obligations of CNH UK LTD. However, CNH UK LTD recommends the use of new, genuine CNH service parts or CNH approved rebuilt parts and assemblies. CNH UK LTD also recommends that the engine be serviced by a CNH authorized dealer.

CNH UK LTD Responsibilities:

Warranty work will be provided at no charge to the owner at any authorized dealer, using genuine CNH service parts or CNH approved rebuilt parts or assemblies.

The owner will not be charged for diagnostic labor which leads to the determination that a warranted part is defective, if the diagnostic work was performed at a warranty station.

CNH UK LTD is liable for damages to other engine components caused by the failure under warranty of any warranted part.

Warranty Limitations

CNH UK LTD is not responsible for failures resulting from abuse or neglect by owner or operator.

CNH UK LTD warrants to the ultimate purchaser and each subsequent purchaser that the engine is designed, built, and equipped so as to conform with all applicable regulations adopted by the Air Resources Board, and that it is free from defects in materials and workmanship which cause the failure of a warranted part.

Any warranted part which is not scheduled for replacement as required maintenance, or which is scheduled only for regular inspection to the effect of "repair or replace as necessary" is warranted for the warranty period.

Any warranted part which is scheduled for replacement as required maintenance is warranted for the period of time prior to the first scheduled replacement point of that part.

CNH UK LTD is not liable to warrant failures caused by the use of add-on or modified parts.

CNH UK LTD is concerned to ensure proper maintenance of the engine to maximise emissions performance. Information on care and replacement of engine air cleaner, and all other aspects of engine maintenance is provided in a manual supplied to the owner. A maintenance schedule chart is provided in the manual.

(North America Only)

(California Only)

CALIFORNIA

Proposition 65 Warning

Diesel engine exhaust and some of its constituents are known to the State of California to cause cancer, birth defects, and other reproductive harm.

Battery posts, terminals and related accessories contain lead and lead compounds, chemicals known to the State of California to cause cancer and birth defects or other reproductive harm. Wash hands after handling.

SECTION 1

GENERAL INFORMATION AND SAFETY

TO THE OWNER

GENERAL

This Manual has been prepared to assist you in the correct procedure for running-in, driving and operating and for the maintenance of your new tractor. Read this Manual carefully. Your tractor is intended for use in normal and customary agricultural applications.

If at any time you require advice concerning your tractor, do not hesitate to contact your authorized dealer. He has factory trained personnel, genuine manufacturers' parts and the necessary equipment to carry out all your service requirements.

Your tractor has been designed and built to give maximum performance, economy and ease of operation under a wide variety of operating conditions. Prior to delivery, the tractor was carefully inspected, both at the factory and by your dealer to ensure that it reaches you in optimum condition. To maintain this condition and ensure trouble-free operation, it is important that the routine services, as specified in Section 4 of this Manual, are carried out at the recommended intervals.

OPERATORS MANUAL STORAGE

A storage pocket for the Operators Manual can be found on the rear of the seat. The manual should be kept in this pocket at all times when not in use.

SAFETY

Pages 1-9 to 1-15, inclusive, list the precautions to be observed to ensure your safety and the safety of others. Read the safety precautions and follow the advice offered before operating the tractor.

CLEANING THE TRACTOR

Your tractor is a state-of-the-art machine with sophisticated, electronic controls. This should be in mind when cleaning the tractor, particularly if using a high pressure washer. Even though every precaution has been taken to safeguard electronic components and connections, the pressure generated by some of these machines is such that complete protection against water ingress cannot be guaranteed.

When using a high pressure washer, do not stand too close to the tractor and avoid directing the jet at electronic components, electrical connections, breathers, seals, filler caps, etc. Never direct a cold water jet at a hot engine or exhaust.

FIRST 50 HOUR SERVICE

In Section 8, at the back of this Manual, you will find the 50-hour service reports.

After you have operated the tractor for 50 hours, take your tractor, together with this Manual, to your dealer. He will then perform the factory recommended 50 hour service and complete the service report sheets (pages 8-1 and 8-3). The first sheet (page 8-1) is the dealer's copy and should be removed by the dealer after the service has been carried out. The second sheet (page 8-3) is your copy of the service performed. Ensure that you and the dealer sign both copies.

SERVICE PARTS

It should be pointed out that genuine parts have been examined and approved by the Company. The installation and/or use of 'non-genuine' products could have negative effects upon the design characteristics of your tractor and thereby affect its safety. The Company is not liable for any damage caused by the use of 'non-genuine' parts and accessories. Only genuine New Holland replacement parts should be used. The use of non-genuine parts may invalidate legal approvals associated with this product.

It is prohibited to carry out any modifications to the tractor unless specifically authorized, in writing, by the After Sales Service department of the Company.

WARRANTY

Your tractor is warranted according to legal rights in your country and the contractual agreement with the selling dealer. No warranty shall, however, apply if the tractor has not been used, adjusted and maintained according to the instructions given in the Operator's Manual.

PRODUCT IDENTIFICATION

The tractor and major components are identified using product identification numbers and/or manufacturing codes. Tractor identification data must be supplied to the dealer when requesting parts or service and will also be needed to aid in identifying the tractor if it is ever stolen.

The following provides the locations of the identification data.

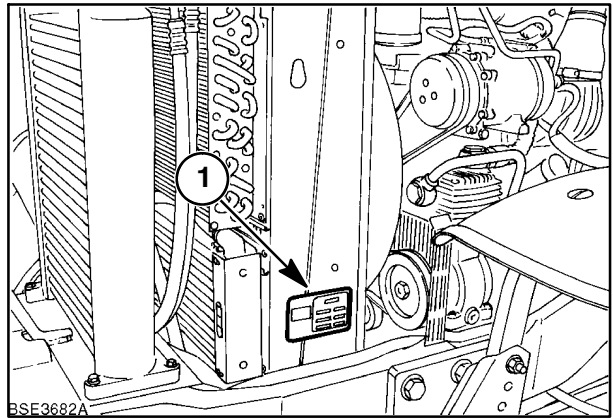

1

Vehicle Identification Plate

The vehicle identification plate, 1, Figure 1 is located on the left-hand radiator support. Record the information on the sample identification plate provided below.

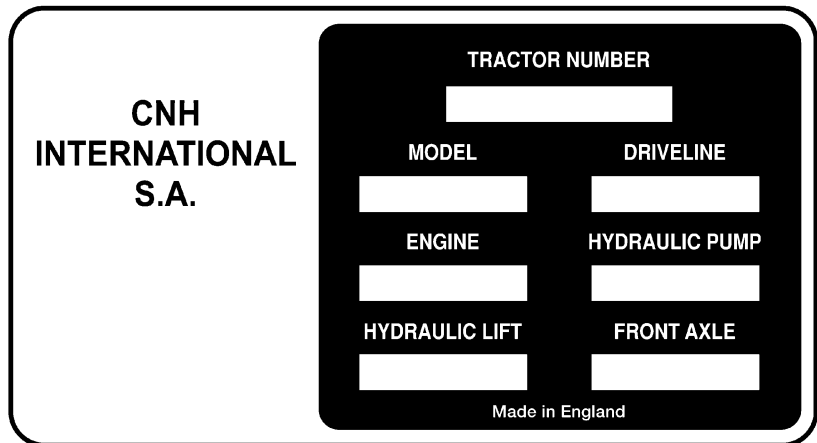

2

Tractor Identification

The product identification number and model identification information is stamped on the top of the front support, 1. These numbers are also repeated on the vehicle identification plate reproduced above.

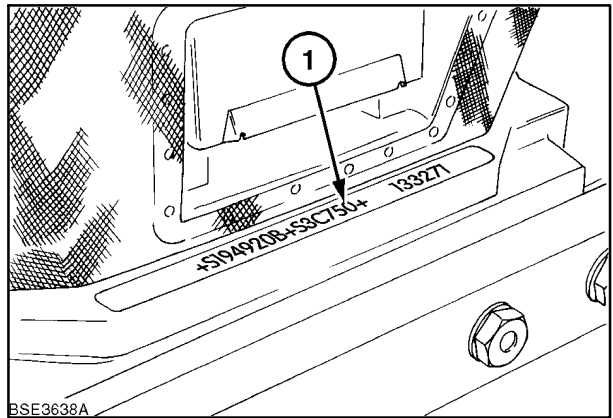

3

SECTION 1 - GENERAL INFORMATION AND SAFETY

Engine Information

The engine product identification number and date of manufacture are stamped on the right-hand side of engine block, 1, below the manifold. Record the number below.

Engine PIN _____

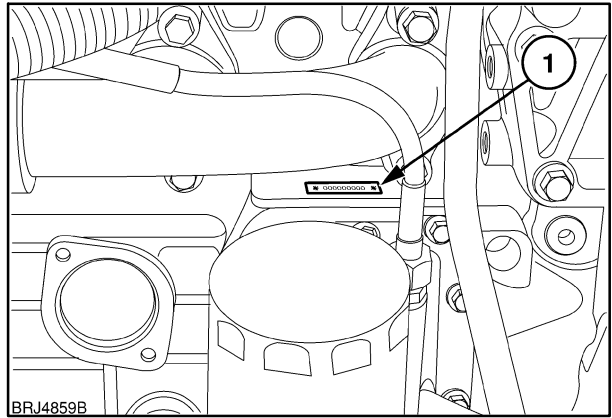

4

The engine product identification number is repeated on the information plate located on the left side of the engine oil pan.

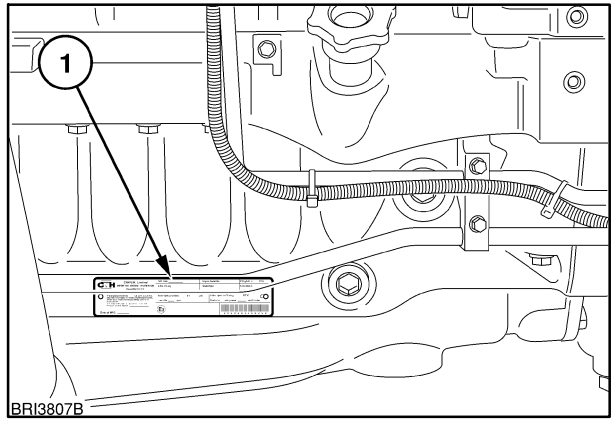

5

Further information relating to engine adjustments and emission level compliance are also shown on the engine information plate.

NOTE: The details displayed on the engine information plate may change according to the country in which the tractor is sold.

	CNH U.K. Limited IMPORTANT ENGINE INFORMATION Assembled in UK	CID/Litre		Engine Serial No.		FEL g/kW-hr		EPA	
		E.P.A. Family		Model Type		NOx+NMHC		PM	
Advertised BHP/kW		rpm		Engine Model					
Valve Lash Cold (mm)		Inlet		Exh.		Initial Injection Timing		BTDC	
Low Idle		rpm		Fuel rate @ advertised power		mm ³ / Stroke			
Date of Manufacture									
				3 8 1 9 3 1 8 7 5 2 0 6 7 8					

Driveline Identification

The product identification number plate, 1, is located on top of the transmission casing. Access to the number can be gained by removing the plate in the floor of the cab as shown in the illustration. This number is repeated on the vehicle identification plate. Record the information below for quick reference.

Driveline PIN _____

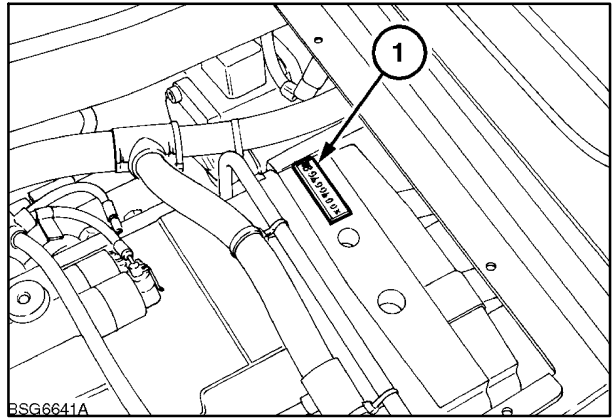

6

Cab Identification

The cab product identification number and other information is on the OECD certification plate. This plate can be found on the right-hand side of the cab trim panel, below the rear window. Record the cab product identification number below for quick reference.

Cab PIN _____

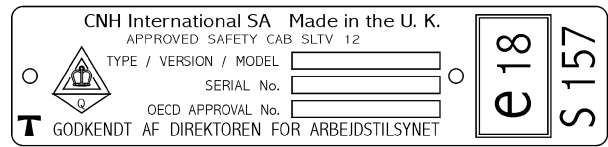

7

TRANSPORTING TOWED EQUIPMENT AT SAFE SPEEDS

Product Identification Number Plate

The Product Identification Number plate provides important information on tractor and towed equipment weight combinations. This plate can be found on the right-hand side of the cab exterior trim panel, below the rear window.

The figures shown are the maximum permissible vehicle and towing weights and should not be exceeded, to do so may affect the safe operation of the tractor. See Drawbars and Towing Attachments in Section 3.

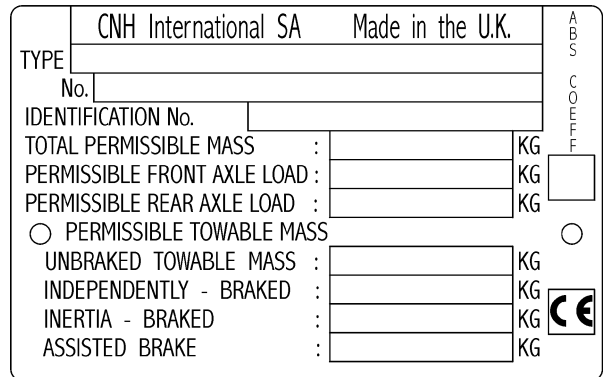

8

ECOLOGY AND THE ENVIRONMENT

Soil, air and water are vital factors of agriculture and life in general. Where legislation does not yet rule the treatment of some of the substances which are required by advanced technology, common sense should govern the use and disposal of products of a chemical and petrochemical nature.

The following are recommendations which may be of assistance:

- Become acquainted with and ensure that you understand the relative legislation applicable to your country.
- Where no legislation exists, obtain information from suppliers of oils, filters, batteries, fuels, anti freeze, cleaning agents, etc., with regard to their effect on man and nature and how to safely store, use and dispose of these substances. Agricultural consultants will, in many cases, be able to help you as well.

HELPFUL HINTS

1. Avoid filling tanks using unsuitable containers or inappropriate pressurized fuel delivery systems which may cause considerable spillage.
2. In general, avoid skin contact with all fuels, oils, acids, solvents, etc. Most of them contain substances which can be harmful to your health.
3. Modern oils contain additives. Do not burn contaminated fuels and/or waste oils in ordinary heating systems.

4. Avoid spillage when draining off used engine coolant mixtures, engine, gearbox and hydraulic oils, brake fluids, etc. Do not mix drained brake fluids or fuels with lubricants. Store them safely until they can be disposed of in a proper way to comply with local legislation and available resources.
5. Modern coolant mixtures, i.e. antifreeze and other additives, should be replaced every two years. They should not be allowed to get into the soil but should be collected and disposed of safely.
6. Do not open the air-conditioning system yourself. It contains gases which should not be released into the atmosphere. Your dealer or air conditioning specialist has a special extractor for this purpose and will have to recharge the system anyway.
7. Repair any leaks or defects in the engine cooling or hydraulic system immediately.
8. Do not increase the pressure in a pressurized circuit as this may lead to the components exploding.
9. Protect hoses during welding as penetrating weld splatter may burn a hole or weaken them, causing the loss of oils, coolant, etc.

Thank you so much for reading.
Please click the “Buy Now!”
button below to download the
complete manual.



After you pay.

You can download the most
perfect and complete manual in
the world immediately.

Our support email:

ebooklibonline@outlook.com