

**PUMA 165 CVX
PUMA 180 CVX
PUMA 195 CVX
PUMA 210 CVX
PUMA 225 CVX
Tractors**

Operator's Manual

Print No. 84273874

3rd edition

English 09/09

Replaces p/n 84210407

CASE II
AGRICULTURE

**PUMA 165 CVX
PUMA 180 CVX
PUMA 195 CVX
PUMA 210 CVX
PUMA 225 CVX
Tractors**

Operator's Manual

Print No. 84273874

3rd edition

English 09/09

Replaces p/n 84210407



CONTENTS

Title	Page
Section 1 - General Information and Safety	
To the Owner	1-1
Product Identification	1-3
Ecology and the Environment	1-7
Safety Precautions	1-8
Safety Decals	1-16
International Symbols	1-22
Airborne Noise Emission	1-23
Section 2 - Controls, Instruments and Operation	
Cab	2-4
Electrical Power Sockets	2-20
Seats	2-23
Instrument Console	2-29
Analogue/Digital Instruments	2-33
Brake Controls and Operation	2-65
CVT Transmission	2-70
Differential Lock and Four Wheel Drive	2-86
Four Wheel Drive	2-88
Front Axle Suspension	2-90

Section 3 - Field Operation

Important Information	3-1
Boosting the Tractor Battery	3-10
Starting the Engine	3-11
Stopping the Engine	3-14
Reversible Engine Fan	3-16
Power Management	3-17
Constant Engine Speed	3-20
Headland Management Control	3-23
Turn Assist	3-40
Rear Power Take-Off	3-42
Front Power Take-Off and Hydraulic Lift	3-57
Electronic Hitch Control	3-80
Electro-Hydraulic Remote Control Valves	3-95
Hydraulic Power Beyond Port	3-122
Three-point Hitch	3-127
Quick Hitch	3-133
Linkage Stabilisers	3-135
Drawbars and Towing Attachments	3-141
Trailer Braking Systems	3-156
Front Wheel Track Adjustment	3-163
Steerable Front Fenders	3-167
Rear Wheel Track Adjustment	3-169
Ballasting and Tyres	3-180

Section 4 - Lubrication and Maintenance

General Information	4-1
Guard Removal	4-8
Lubrication and Maintenance Chart	4-12
Servicing: When Warning Lights Illuminate	4-15
10-hour/daily service	4-18
50-hour service	4-20
100-hour service	4-32
300-hour service	4-33
600-hour service	4-37
1200-hour/12 month service	4-46
1200-hour/24 month service	4-53
Every 3 years	4-60
General Maintenance - as required	4-61
Storing the Tractor	4-83

Section 5 - Fault Finding

Introduction	5-1
Engine	5-4
Transmission	5-7
Hydraulics	5-8
3-point Hitch	5-9
Brakes	5-10
Cab	5-10
Electrical	5-11

Section 6 - Accessories

Colour Display Monitor	6-2
ISO Connector	6-2
Auto Guidance	6-3
Rotating Beacon	6-4
Auxiliary Headlights	6-4
Battery Isolator Switch	6-5

Section 7 - Specification

General Dimensions 7-2
Vehicle Weights 7-6
Lubricant and Fluid Capacities 7-7
Engine 7-8
Fuel System 7-8
Cooling System 7-9
Transmission 7-10
Maximum Operating Angle 7-10
Rear Power Take-Off 7-10
Front Power Take-Off 7-11
Hydraulic System 7-11
Rear 3-Point Hitch 7-11
Remote control valves 7-16
Front 3-Point Hitch 7-16
Front Remote Valves 7-16
Brakes 7-17
Steering 7-17
Electrical Equipment 7-18
Hardware Torque Tables 7-19

Section 8 - First 50-hour Service Forms 8-1

Section 9 - Index 9-1



SECTION 1

GENERAL INFORMATION AND SAFETY

TO THE OWNER

GENERAL

This Manual has been prepared to assist you in the correct procedure for running-in, driving and operating and for the maintenance of your new tractor. Read this Manual carefully. Your tractor is intended for use in normal and customary agricultural applications.

If at any time you require advice concerning your tractor, do not hesitate to contact your authorised dealer. He has factory trained personnel, genuine manufacturers' parts and the necessary equipment to carry out all your service requirements.

Your tractor has been designed and built to give maximum performance, economy and ease of operation under a wide variety of operating conditions. Prior to delivery, the tractor was carefully inspected, both at the factory and by your dealer to ensure that it reaches you in optimum condition. To maintain this condition and ensure trouble-free operation, it is important that the routine services, as specified in Section 4 of this Manual, are carried out at the recommended intervals.

OPERATORS MANUAL STORAGE

A storage pocket for the Operators Manual can be found on the rear of the seat. The manual should be kept in this pocket at all times when not in use.

SAFETY

Pages 1-8 to 1-15 inclusive list the precautions to be observed to ensure your safety and the safety of others. Read the safety precautions and follow the advice offered **before** operating the tractor.

CLEANING THE TRACTOR

Your tractor is a state-of-the-art machine with sophisticated, electronic controls. This should be taken into consideration when cleaning the tractor, particularly if using a high pressure washer. Even though every precaution has been taken to safeguard electronic components and connections, the pressure generated by some of these machines is such that complete protection against water ingress cannot be guaranteed.

When using a high pressure washer, do not stand too close to the tractor and avoid directing the jet at electronic components, electrical connections, breathers, seals, filler caps, etc. Never direct a cold water jet at a hot engine or exhaust.

ELECTRO-MAGNETIC INTERFERENCE (EMC)

This tractor complies strictly with the European Regulations on electro-magnetic emissions. However, interference may arise as a result of add-on equipment which may not necessarily meet the required standards. As such interference can result in serious malfunction of the unit and/or create unsafe situations, you must observe the following:

- Ensure that each piece of third party equipment fitted to the tractor bears the CE mark.
- The maximum power of emission equipment (radio, telephones, etc.) must not exceed the limits imposed by the national authorities of the country where you use the tractor.
- The electro-magnetic field generated by the add-on system should not exceed 24 V/m at any time and at any location in the proximity of electronic components.

Failure to comply with these rules will render the warranty null and void.

FIRST 50 HOUR SERVICE

In Section 8, at the back of this Manual, you will find the 50-hour service reports.

IMPORTANT: *It is important the 50 hour service is carried out as recommended to ensure your tractor provides optimum performance and efficiency.*

After you have operated the tractor for 50 hours, take your tractor, together with this Manual, to your dealer. He will then perform the factory recommended 50 hour service and complete the service report sheets (pages 8-1 and 8-3). The first sheet (page 8-1) is the dealer's copy and should be removed by the dealer after the service has been carried out. The second sheet (page 8-3) is your copy of the service performed. **Ensure that you and the dealer sign both copies.**

SERVICE PARTS

It should be pointed out that genuine parts have been examined and approved by the Company. The installation and/or use of 'non-genuine' products could have negative effects upon the design characteristics of your tractor and thereby affect its safety. The Company is not liable for any damage caused by the use of 'non-genuine' parts and accessories. Only genuine replacement parts should be used. The use of non-genuine parts may invalidate legal approvals associated with this product.

It is prohibited to carry out any modifications to the tractor unless specifically authorised, in writing, by the After Sales Service department of the Company.

WARRANTY

Your tractor is warranted according to legal rights in your country and the contractual agreement with the selling dealer. No warranty shall, however, apply if the tractor has not been used, adjusted and maintained according to the instructions given in the Operator's Manual.

USE OF BIODIESEL FUELS

IMPORTANT: *Before using Biodiesel fuels in your tractor, refer to the information on page 4-5 regarding the storage and use of Biodiesel fuels.*

PRODUCT IDENTIFICATION

The tractor and major components are identified using serial numbers and/or manufacturing codes.

Tractor identification data must be supplied to the dealer when requesting parts or service and will also be needed to aid in identifying the tractor if it is ever stolen.

The following provides the locations of the identification data.

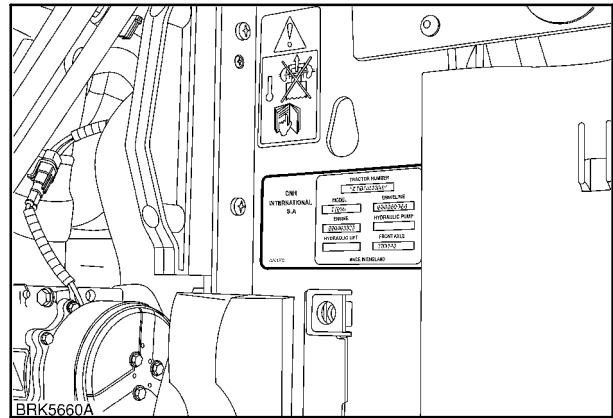

1

Vehicle Identification Plate

The vehicle identification plate, Figure 1, is located on the right-hand radiator support. Record the information on the sample identification plate provided below.

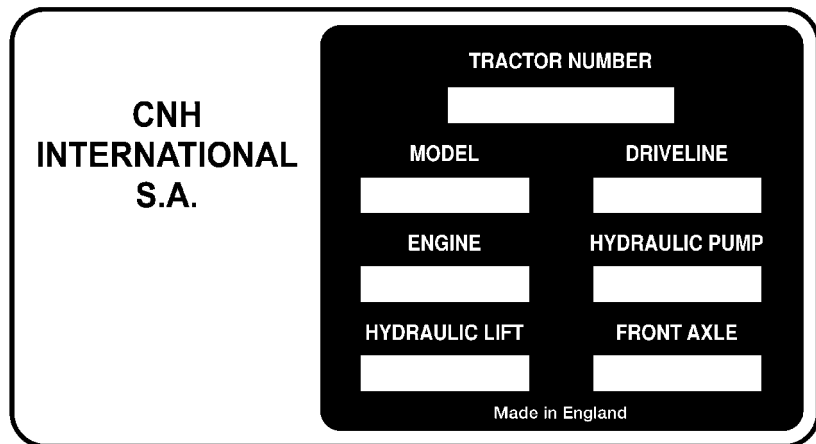

2

Tractor Serial Number

The serial number and model identification information is stamped on the right-hand side of the front support (1). These numbers are also repeated on the vehicle identification plate reproduced above.

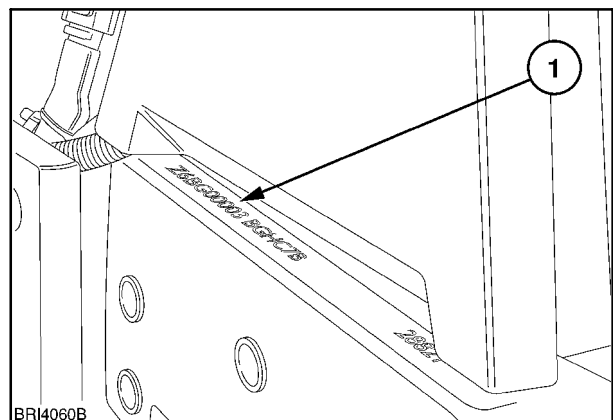

3

Engine Identification

The engine serial number and date of manufacture are stamped on the right-hand side of engine block (1), below the manifold. Record the number below.

Engine Serial No. _____

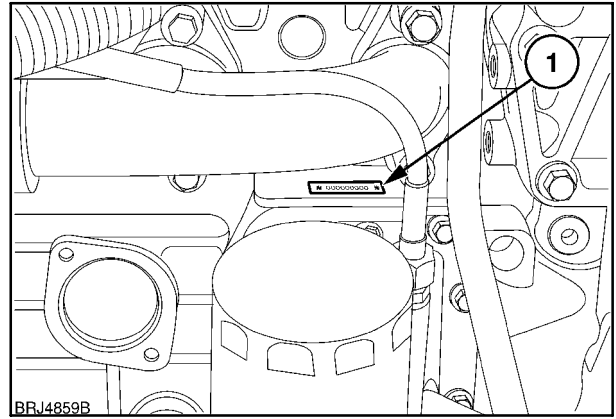

4

The details are repeated on the information plate located on the left side of the engine oil pan.

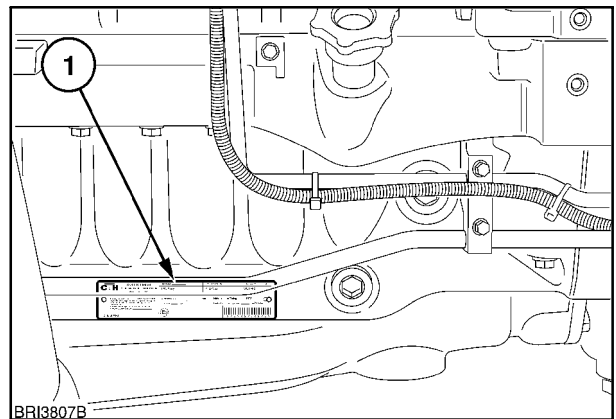

5

Further information relating to engine adjustments and emission level compliance are also shown on the engine information plate.

NOTE: The details displayed on the engine information plate may change according to the country in which the tractor is sold.

	CNH U.K. Limited IMPORTANT ENGINE INFORMATION Assembled in UK	ODI/Size	Engine Serial No.	FEL g/kW-hr	EPA	
		E.P.A. Family	Model Type	NOx+MMHC	PM	PM
This engine conforms to US, E.P.A. & California Regulations for large non-road compression ignition diesel engines. This engine is designed to operate on commercially available diesel fuel. When making adjustments set parking brake and block wheels.	Date of Manufacture	Advertised BHP/kW	rpm	Engine Model	PM	
		Valve Lash Cold (mm)	Inlet	Exh.	Initial Injection Timing	BTDC
		Low Idle	rpm	Fuel rate @ advertised power		mm ³ /Stroke
		e3	e3			
3 8 1 9 3 1 8 7 5 2 0 6 7 8						

Driveline Identification

CVT Transmission

A serial number plate (1) is located on top of the transmission casing on the right-hand side of the tractor.

The plate can be found adjacent to the rear of the hydrostatic drive unit. This number is repeated on the vehicle identification plate and should be recorded below for quick reference.

Driveline Serial No. _____

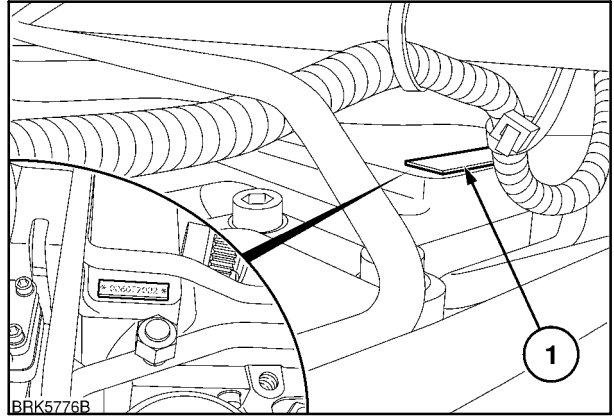

6

Cab Identification

The cab serial number and other information is on the OECD certification plate. This plate can be found on the right-hand side of the cab trim panel, below the rear window. Record the cab serial number below for quick reference.

Cab Serial No. _____



7

Buy Now



Our support email:

ebooklibonline@outlook.com