

OPERATOR'S MANUAL

T8.275

T8.300

T8.330

T8.360

T8.390

Tractor

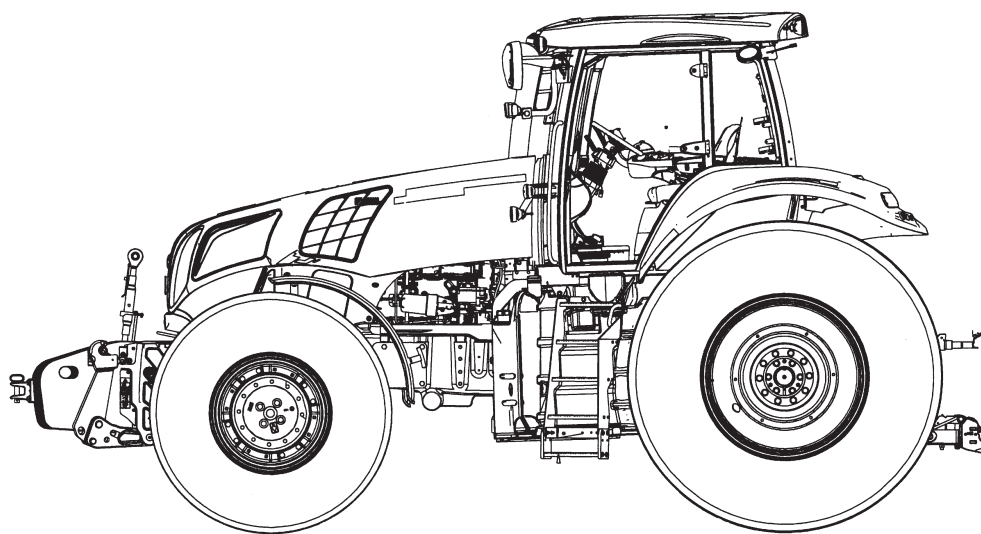

Part number 84309497

1st edition English

March 2011



Contents

1 GENERAL INFORMATION

Your tractor	1-1
Tractor intended use.....	1-2
Note to the Owner	1-3
Manual storage	1-3
Product identification	1-4
Machine orientation.....	1-6
Component location	1-7

2 SAFETY INFORMATION

Safety rules and signal word definitions	2-1
Read the Operators Manual	2-2
Proposition 65	2-2
Safety rules - General	2-2
Safety rules - Air conditioning system	2-3
Safety rules - Basic operating	2-3
Safety rules - Battery	2-4
Safety rules - Driving on public roads	2-4
Safety rules - Electrical storm safety	2-5
Safety rules - Fire prevention	2-5
Safety rules - General maintenance	2-5
Safety rules - Hazardous chemicals	2-7
Safety rules - Implements, tools and trailers	2-7
Safety rules - Instructional seat	2-7
Safety rules - Mounting and dismounting	2-8
Safety rules - Operator presence system	2-8
Safety rules - PTO operation	2-8
Safety rules - Roll over and tip over	2-9
Safety rules - Utility power lines	2-9
Safety rules - Vehicle vibration	2-10
Safety rules - Wheels and tires	2-10
Roll over protective structure (ROPS).....	2-12
Roll over protective structure (ROPS).....	2-13
Safety decals	2-14
Selective catalytic reduction (SCR) decal	2-22
Ecology and the environment	2-23

3 CONTROLS/INSTRUMENTS

ACCESS TO OPERATOR'S PLATFORM

Tractor access.....	3-1
---------------------	-----

OPERATOR'S SEAT

Overview	3-2
Control identification.....	3-3

INSTRUCTOR'S SEAT	
Overview	3-6
FORWARD CONTROLS	
Steering column	3-7
Front console	3-10
Pedal controls	3-12
LEFT-HAND SIDE CONTROLS	
Pneumatic trailer brake	3-14
RIGHT-HAND SIDE CONTROLS	
Armrest console	3-15
Multi function handle	3-17
Hand throttle lever	3-20
Control panel	3-21
Remote valve controls	3-29
Joystick	3-30
Rear hitch controls	3-32
Armrest compartment	3-35
Adjusting the armrest console	3-37
REARWARD CONTROLS	
Fender console	3-38
Automatic temperature controls	3-41
Automatic temperature control system	3-44
Ventilation	3-45
OVERHEAD CONTROLS	
Interior lamps	3-47
EXTERIOR CONTROLS	
Rear fender controls	3-48
Front hitch	3-49
INSTRUMENT CLUSTER	
Overview	3-50
Gauges	3-50
Status and warning icons	3-52
Upper display	3-55
Lower display	3-57
Keypad	3-59
Setup menu	3-61
Rear tire radius chart	3-67
Adjust menu	3-68
Performance instrumentation	3-75

4 OPERATING INSTRUCTIONS

COMMISSIONING THE UNIT

Before starting the engine	4-1
----------------------------------	-----

STARTING THE UNIT

Normal engine starting	4-4
Cold starting aids	4-7
Cold temperature operation	4-9

STOPPING THE UNIT

Stopping the engine	4-11
---------------------------	------

MOVING THE UNIT

Powershift transmission	4-12
Best practices for prolonged transmission life	4-13
Inching pedal and throttle	4-14
Transmission controls	4-15
Upper display	4-18
Driving the vehicle	4-20
Setting default gears	4-25
Ground speed management (GSM)	4-27
Selective catalytic reduction (SCR) system	4-32
Mechanical front drive (MFD)	4-37
Differential lock system	4-41
Suspended axle	4-44
Ride control	4-52
Constant engine speed	4-54
Headland management system	4-56

5 TRANSPORT OPERATIONS

ROAD TRANSPORT

Tractor warning lamps and SMV symbol	5-1
Wide transport marker light	5-2
Tractor warning lamps	5-4
Safe transport speed	5-5
Implement warning lamps and SMV symbol	5-6
Safety chain	5-7

SHIPPING TRANSPORT

Securing the tractor for shipping	5-8
---	-----

RECOVERY TRANSPORT

Safety rules	5-9
Towing the tractor	5-10

6 WORKING OPERATIONS

GENERAL INFORMATION

Product overview	6-1
------------------------	-----

REAR PTO

Safety rules	6-2
Connecting the PTO	6-5
Interchangeable PTO shaft	6-6
Rear PTO operation	6-12
PTO fender switch operation	6-16
Auto PTO operation	6-17

FRONT PTO

Front PTO operation	6-20
---------------------------	------

REAR HITCH

Identification	6-23
Link adjustment	6-24
Hitch high clearance adjustment	6-28
Hydraulic links	6-31
Sway limiter adjustment	6-33
Lower link block adjustment	6-34
Mechanical float adjustment	6-35
Hitch quick coupler - Category III/IIIN	6-36
Hitch quick coupler - Category IVN	6-41
Hitch operation	6-45
Hitch remote switch operation	6-50
Position control operation	6-51
Load control operation	6-53
Slip control operation	6-55
Hitch set point	6-57

FRONT HITCH

Overview	6-59
Front hitch operation	6-59

DRAWBARS AND TOWING ATTACHMENTS

Rear towing - Safety rules	6-67
Drawbar capacity/position	6-68
Adjusting the drawbar	6-72

AUXILIARY POWER CONNECTIONS

Auxiliary power and lighting	6-74
Cab power connections	6-76

HYDRAULIC REMOTE CONTROL VALVES

Valve couplers and connections	6-78
Motor return circuit	6-81
Power beyond circuit	6-82
Flow capacity	6-82
Hydraulic transport lock	6-84
Operating the controls	6-85
Remote valve display screens.....	6-89
Remote hydraulic auto mode	6-93
Auto depth control	6-95
Joystick operation	6-97

BALLASTING THE TRACTOR

Guidelines	6-101
Tire load and inflation charts	6-106
Weights, cast metal and liquid.....	6-114
Wheel slip and power hop performance	6-126

MECHANICAL FRONT DRIVE (MFD) AXLES

Tire combinations and tread positions.....	6-129
Steering and oscillation stops	6-136
Tread and fender settings - standard MFD axles.....	6-142
Tread and fender settings - heavy duty MFD axles	6-147
Tread and fender settings - heavy duty class 5 MFD axles	6-154
Tread and fender settings - heavy duty class 5 suspended MFD axles.....	6-162

REAR AXLE

Rear wheel installation	6-170
Rear wheel tread settings	6-173

7 MAINTENANCE

GENERAL INFORMATION

Safety rules	7-1
Opening the hood	7-2
Closing the hood	7-4
Filling the fuel tank	7-5
Filling the DEF/AdBlue® tank	7-6
Battery access and service.....	7-7
Tire and rim service.....	7-9
Tractor jacking points.....	7-11
Capacities	7-13
Consumables - Engine oil	7-15
Consumables - Diesel fuel	7-17
Consumables - Biodiesel fuel	7-18
Consumables - Diesel exhaust fluid (DEF)/AdBlue®	7-20

Consumables - Coolant solutions	7-22
Electrical component location	7-23
Lamps and bulbs	7-28
Maintenance chart notes	7-29

MAINTENANCE CHART

Maintenance Chart	7-30
-------------------------	------

At warning message display

Air filter service icon/message.....	7-32
Fuel filter water separator	7-33
Transmission oil filter switch.....	7-34
Hydraulic oil filter switch.....	7-37

First 10 to 50 hours

Differential and planetary oil.....	7-40
Wheel bolt torque.....	7-40
Weight bolt torque	7-40

Every 10 hours or daily

Engine oil level	7-41
Transmission oil level.....	7-42
Engine coolant level	7-43
Engine auxiliary fuel filter	7-44
Air reservoir.....	7-45
Rear hitch and front axle	7-46

Every 50 hours or weekly

Engine fuel pre-filter	7-47
------------------------------	------

Every 100 hours

Front hitch	7-48
-------------------	------

Every 300 hours

Battery water level (Note E)	7-50
Engine air intake hoses.....	7-52
Engine coolant level - deaeration tank	7-54
Wheel bolt torque.....	7-55
Weight bolt torque	7-55
Front axle (Note A)	7-56
Rear hitch (Note A)	7-65
Fuel tank	7-67
Differential and planetary oil level (Note B).....	7-68
Transmission oil pressure	7-70
Front PTO oil level.....	7-71

Every 400 hours

Cab air filter	7-72
----------------------	------

Every 600 hours

Engine oil and filter	7-75
Engine coolant antifreeze protection	7-77
Engine coolant hoses and clamps.....	7-77
Engine primary fuel filter.....	7-80
Engine fuel pre-filter	7-83
Fuel system bleeding.....	7-86
Changeable PTO internal splines	7-88
DEF/AdBlue® in-line filter	7-89
Front PTO oil and filter	7-91

Every 1000 hours or annually

Pneumatic brake system dryer	7-92
------------------------------------	------

Every 1200 hours or annually

Differential and planetary oil.....	7-92
Engine air filters	7-97
Engine air precleaner.....	7-101

Every 1500 hours

Transmission oil	7-103
Transmission oil filter	7-105
Regulated transmission filter	7-106
Engine crankcase filter	7-107

Every 1800 hours

DEF/AdBlue® supply module filter	7-111
--	-------

Every 2000 hours

Engine coolant.....	7-112
Engine valve adjustment (Note C).....	7-114

Every 3000 hours

Engine vibration damper (Note C).....	7-115
Emergency steering system.....	7-116

Every 5000 hours

Fuel injector nozzles (Note C)	7-117
--------------------------------------	-------

As required

Vehicle fire prevention	7-118
Engine primary air filter	7-119
Grille screen and radiator area	7-122
Fuel tank vent filter	7-124
Transmission clutch and accumulator	7-124
Tire pressure	7-124
Fan belt	7-125
Cab suspension, if equipped	7-128
Remote valve collection bottle	7-129
Engine auxiliary fuel filter	7-130
Cab fabric and carpet	7-132
Seat belt	7-132

STORAGE

Tractor storage	7-133
Removal from storage	7-134

ELECTRICAL SYSTEM

Radio or audio system	7-135
Battery removal and installation	7-136
Auxiliary battery connections	7-138
Head light - Replace	7-139
Grille work light	7-143
Fender tail light and warning light	7-145
Roof warning light	7-147
Roof work light	7-149
Belt line, roof or fender work light	7-151
High intensity work light	7-153
Wide transport marker light	7-155
Rotating beacon light	7-156
Interior light - Replace	7-157

8 TROUBLESHOOTING

ALARM(S)

Display warnings overview	8-1
Display warnings - Level 1	8-2
Display warnings - Level 2	8-5
Display warnings - Level 3	8-8
Display warnings - Level 4	8-10

SYMPTOM(S)

Engine symptoms	8-12
Transmission symptoms	8-14
Hydraulic symptoms	8-15
Hitch symptoms	8-16
Brake symptoms	8-17

Cab environment symptoms.....	8-18
Electrical power system symptoms.....	8-19

9 SPECIFICATIONS

Engine specifications	9-1
Power train specifications	9-2
Operating speeds.....	9-5
Vehicle dimensions and shipping weight	9-13
Maximum operating weight.....	9-16

10 ACCESSORIES

Front wheel fenders - Dynamic fenders	10-1
Farming system displays	10-8
Chemical tank mounting.....	10-9
Loader connection and operation	10-11
Trailer brake connections.....	10-12
General accessories.....	10-14

11 FORMS AND DECLARATIONS

Delivery report - owner copy	11-1
Delivery report - dealer copy	11-2
First service - owner copy	11-4
First service - dealer copy	11-6

1 - GENERAL INFORMATION

Your tractor

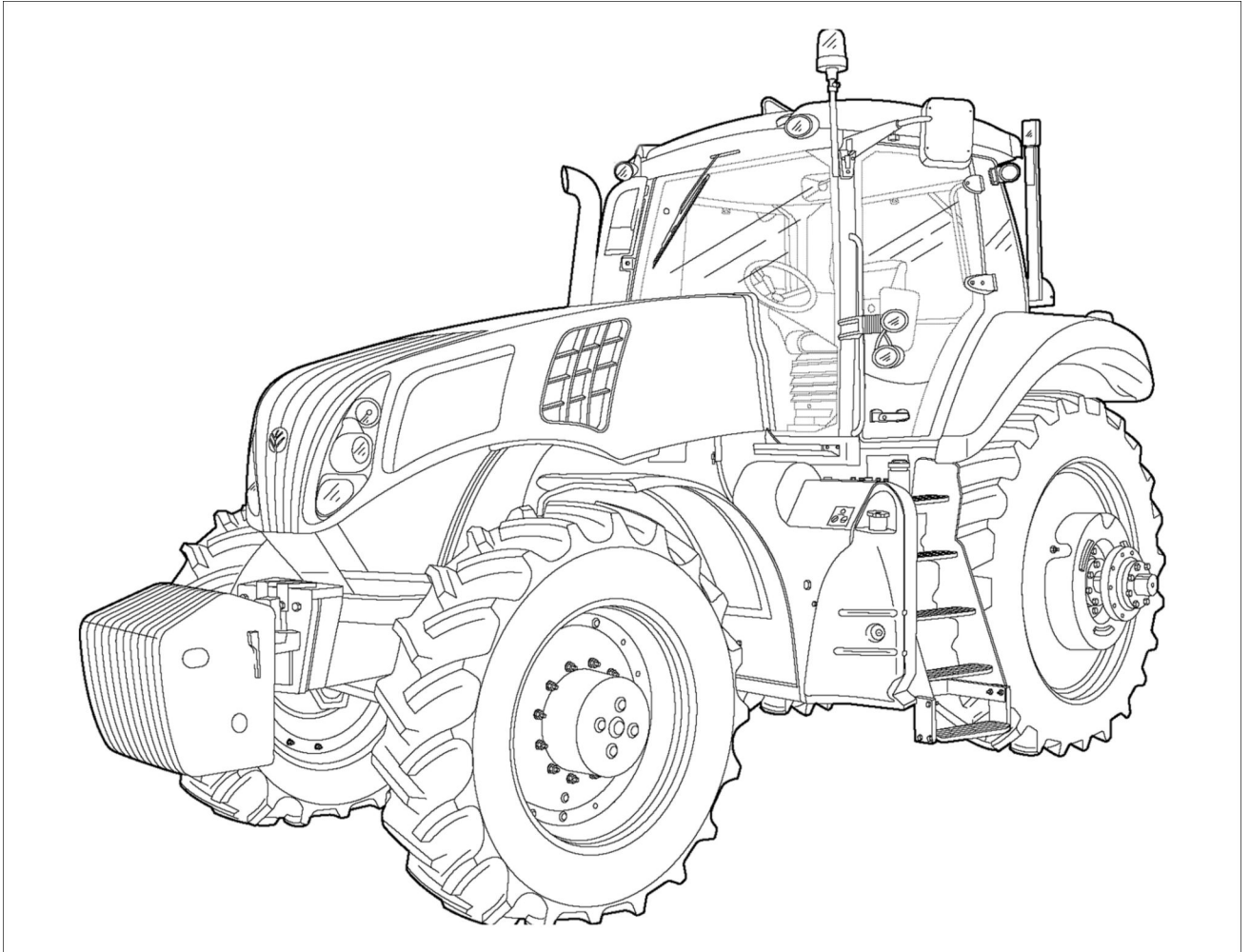

RCPH11CCH004FAB 1

Tractor intended use

T8. series tractors with standard equipment and authorized attachments, are intended to be used for customary farming, land leveling and related agriculture operations (intended use). Installation of utility (dozer) blades, tile plows, or push bars on the tractor is not recommended. Any tractor damage resulting from the installation and/or use of such equipment is not covered by the tractor warranty.

Consult an authorized dealer or CNH America LLC on changes, additions or modifications that can be required for this machine to comply with various regulations and safety requirements. Unauthorized modifications will cause serious injury or death. Anyone making such unauthorized modifications is responsible for the consequences.

Engine and its systems

The fuel system, exhaust after-treatment system, and engine on your machine are designed and built to government emissions standards. Tampering by dealers, customers, operators, and users is strictly prohibited by law.

The tractor is not designed for light/heavy forestry applications; usage is prohibited for forestry applications.

Do not use this machine for any purpose or in any manner other than as described in the manual, decals, or other product safety information provided with the machine. These materials define the machine's intended use.

Use in any other way is considered as contrary to the intended use. The manufacture accepts no liability for any damage or injury resulting from this misuse and these risks must be born solely by the user.

Failure to comply could result in government fines, rework charges, invalid warranty, legal action, and possible confiscation of the machine until rework to original condition is completed. Engine service and/or repairs must be done by a certified technician only!

Electro-magnetic compatibility (EMC)

Electro-magnetic interference may result from add-on equipment which does not meet required standards. Such interference can result in a serious malfunction and/or create unsafe situations, and must be avoided by following these guidelines:

- The maximum power of emission equipment (radio, telephones, etc.) must not exceed the limits imposed by the governing authority where you use the machine.
- The electro-magnetic field generated by the add-on system should not exceed **24 V/m** at any time and at any location in the proximity of electronic components.
- Add-on equipment must not interfere with the functioning of the on board electronics.

Failure to comply with these rules will render the NEW HOLLAND warranty null and void.

Note to the Owner

This manual contains important information about the safe operation, adjustment and routine maintenance of your T8. series tractor. The manual is divided into eleven chapters as outlined in the table of contents. Refer to the index at the end of this manual for locating specific items about your tractor.

Do NOT operate or permit anyone to operate or service this machine until you or the other persons have read this manual. Use only trained operators who have demonstrated the ability to operate and service this machine correctly and safely.

This Operator's Manual is to be stored in the manual compartment behind the operator's seat in the vehicle. Make

sure this manual is in good condition. Contact your dealer to obtain additional manuals.

Your NEW HOLLAND dealer will instruct you in the general operation of your new equipment. Your dealer's staff of factory-trained service technicians will be glad to answer any questions that may arise regarding the operation of your machine. They will also provide any after-sales service you may need, and genuine NEW HOLLAND parts, your guarantee of quality and match.

New Holland Top Service is also available. Call 1-866-NEWHLND (1-866-639-4563) or email na.topservice@cnh.com.

Manual storage

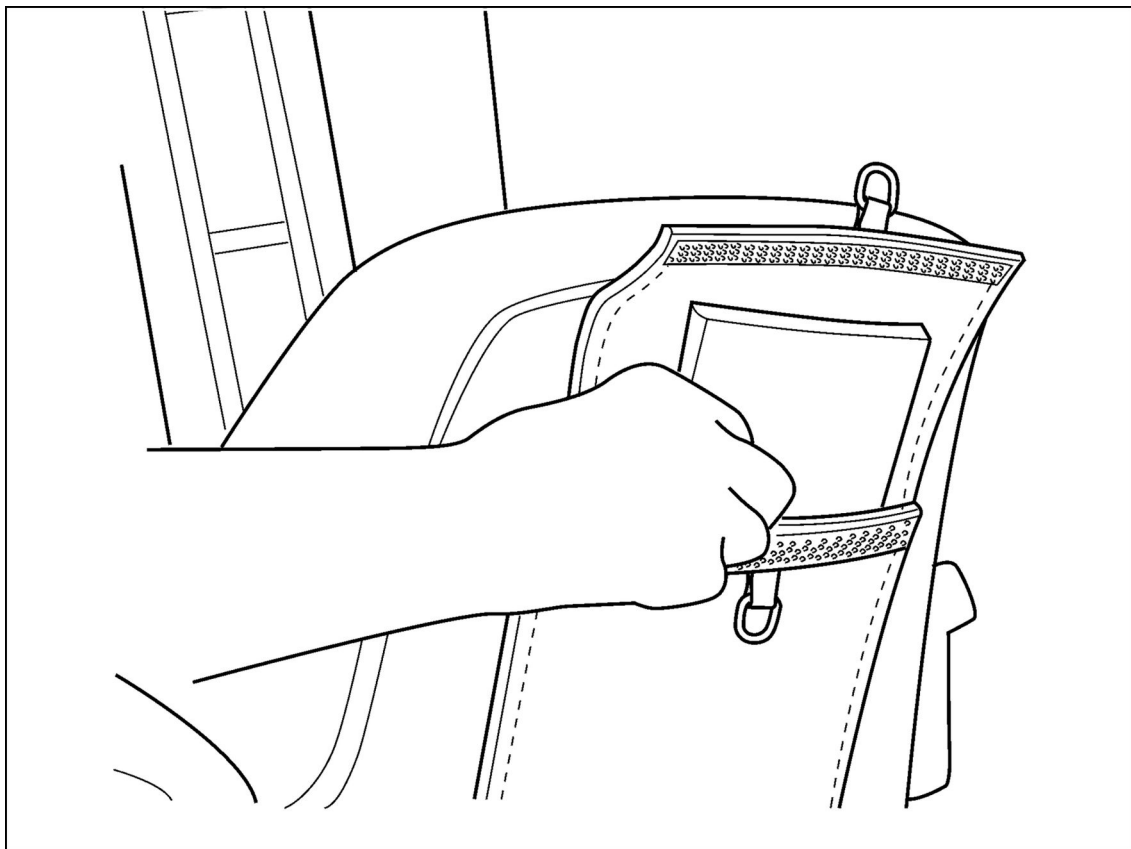



RCPH08CCH001FAB 1

Keep the Operator's Manual in the storage compartment provided on your tractor. The Operator's Manual must be available for use by all operators.

Product identification

Tractor model and product identification number

Write your model number, product identification number (PIN) or serial number of major components on the lines provided. If needed, give these numbers to your dealer when you need parts or information for your machine.

 CNH America LLC Racine, WI 53404 U.S.A. Made In U.S.A.		 MP04
Type 1	EEC Number 2	Product Identification Number 3
• Total Permissible Mass (*): 4 kg • Permissible Front Axle Load (*): 5 kg • Permissible Rear Axle Load (*): 6 kg (* Depending on the Tires)		Permissible Towable Mass: • Unbraked Towable Mass: 7 kg • Independently-Braked Towable Mass: 8 kg • Inertia-Braked Towable Mass: 9 kg • Towable Mass Fitted with an Assisted Braking System: (Hydraulic or Pneumatic): 10 kg

RCIL11CCH008EAA 1

1. Type	Permissible towable mass:
2. EEC number	• 7. Unbraked towable mass
3. Product identification number	• 8. Independently brakes towable mass
4. Total permissible mass	• 9. Inertia braked towable mass
5. Permissible front axle load	• 10. Towable mass fitted with an assisted braking system (hydraulic or pneumatic)
6. Permissible rear axle load	

Model :

Serial number:

NOTE: Located on right hand front casting. Pin plate may be mounted vertically or horizontally.

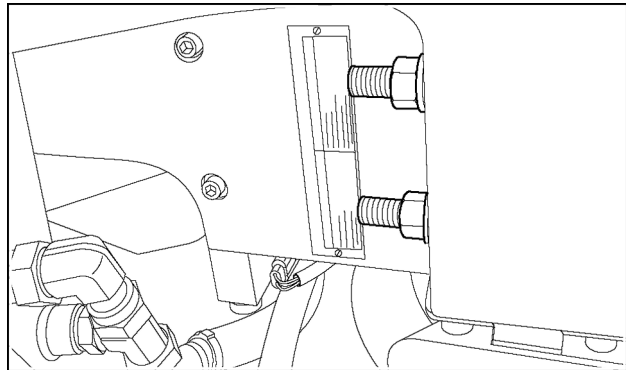

RCPH11CCH117AAB 2

Roll over protection system (ROPS) serial number

NOTE: Located on the right hand cab floor.

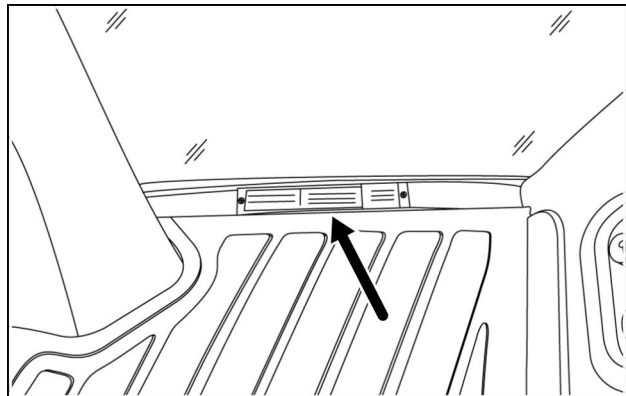

RCPH11CCH014AAB 3

Thank you so much for reading.
Please click the “Buy Now!”
button below to download the
complete manual.



After you pay.

You can download the most
perfect and complete manual in
the world immediately.

Our support email:

ebooklibonline@outlook.com