

# **NEW HOLLAND**

## **LS25-15G**

### **Yard Tractor**

Model No.  
715691006 – T0A0001 & Up

# **OPERATOR'S**

## **MANUAL**



**NEW HOLLAND**

**SERVICE**

# Introduction

Thank you for purchasing a New Holland product.

All of us at New Holland want you to be completely satisfied with your new product, so feel free to contact your local Authorized Service Dealer for help with service, genuine replacement parts, or other information you may require.

Whenever you contact your Authorized Service Dealer or the factory, always know the model and serial numbers of your product. These numbers will help the Service Dealer or Service Representative provide exact information about your specific product. You will find the model and serial number plate located in a unique place on the product as shown below.

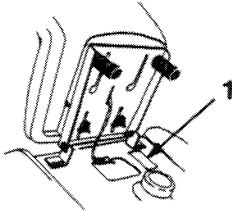

1202a

1. Model and Serial Number Plate (under the seat)

For your convenience, write the product model and serial numbers in the space below.

 <b>NEW HOLLAND</b>	
MODEL NO.	SERIAL NO.
COMPONENT	
NEW HOLLAND NORTH AMERICA, INC. <small>MADE IN U.S.A.</small>	

Read this manual carefully to learn how to operate and maintain your product correctly. Reading this manual will help you and others avoid personal injury and damage to the product. Although we design, produce and market safe, state-of-the-art products, you are responsible for using the product properly and safely. You are also responsible for training persons, who you allow to use the product, about safe operation.

The warning system in this manual identifies potential hazards and has special safety messages that help you and others avoid personal injury, even death. DANGER, WARNING and CAUTION are signal words used to identify the level of hazard. However, regardless of the hazard, be extremely careful.



**DANGER** signals an extreme hazard that will cause serious injury or death if the recommended precautions are not followed.

**WARNING** signals a hazard that may cause serious injury or death if the recommended precautions are not followed.

**CAUTION** signals a hazard that may cause minor or moderate injury if the recommended precautions are not followed.

Two other words are also used to highlight information. "Important" calls attention to special mechanical information and "Note" emphasizes general information worthy of special attention.

The left and right side of the machine is determined by sitting on the seat in the normal operator's position.

	<b>WARNING:</b>	
<b>The engine exhaust from this product contains chemicals known to the State of California to cause cancer, birth defects, or other reproductive harm.</b>		

**IMPORTANT:** The engine in this product is not equipped with a spark arrester muffler. It is a violation of California Public Resource Code Section 4442 to use or operate this engine on any forest-covered, brush-covered or grass-covered land as defined in CPRC 4126. Other states or federal areas may have similar laws.



## LS25 - YARD TRACTOR

MODEL NO. 715691006-T0A0001 & UP

SET-UP  
INSTRUCTIONS

### Loose Parts

**Note:** Use the chart below to identify parts for assembly.

DESCRIPTION	QTY.	USE
Battery	1	Activate Battery .
Key	2	Use in ignition switch, Operate in Reverse switch
Operator's Manual	1	Read manual before operating tractor.

### Check Tire Pressure

Check front and rear tire pressure.

Pressure: 20 psi (138 kPa) front and rear.

### Activate the Battery

Tractors are shipped with a dry battery. Bulk electrolyte with 1.260 specific gravity must be purchased from a local battery supply outlet.

1. Remove the battery from the tractor: refer to Operator's Manual, Removing the Battery.

**IMPORTANT:** Be careful not to damage the long vent tube when removing the battery box.

### DANGER

#### POTENTIAL HAZARD

- Battery electrolyte contains sulfuric acid which is a deadly poison and it causes severe burns.

#### WHAT CAN HAPPEN

- If you drink electrolyte you could die or if it gets onto your skin you will be burned.

#### HOW TO AVOID THE HAZARD

- Do not drink electrolyte and avoid contact with skin, eyes or clothing. Wear safety glasses to shield your eyes and rubber gloves to protect your hands.
- Fill the battery where clean water is always available for flushing the skin.
- Follow all instructions and comply with all safety messages on the electrolyte container.

2. Remove filler caps from the battery. Slowly pour electrolyte into each cell until the electrolyte level is up to the lower part of the tube (Fig. 1).

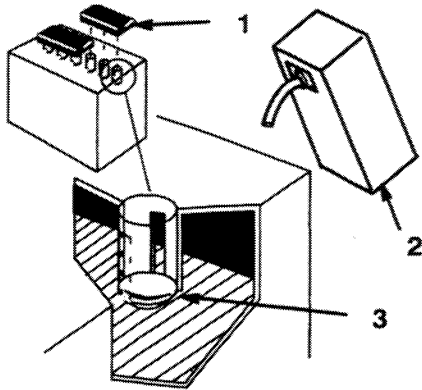

1262

Figure 1

1. Filler caps
2. Electrolyte
3. Lower part of the tube

3. Leave the covers off and connect a 3 to 4 amp battery charger to the battery posts (Fig. 2). Charge the battery at a rate of 4 amperes or less for 4 hours (12 volts).

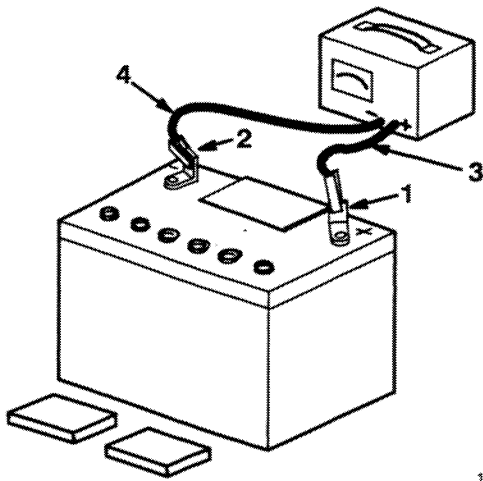

1254

Figure 2

1. Positive post
2. Negative post
3. Charger red (+) wire
4. Charger black (-) wire

## WARNING

### POTENTIAL HAZARD

- Charging battery produces gasses.

### WHAT CAN HAPPEN

- Battery gasses can explode.

### HOW TO AVOID THE HAZARD

- Keep cigarettes, sparks and flames away from battery.

4. When the battery is fully charged, disconnect the charger from the electrical outlet and from the negative and positive battery posts (Fig. 2).
5. Slowly pour electrolyte into each cell until the level is up to the "UPPER" line on the battery case (Fig. 1) and install covers.
6. Install the battery in the tractor and connect cables with (2) 1/4 x 3/4" bolts and (2) 1/4" plastic wing nuts: refer to the Operator's Manual, Installing the Battery.

## Check Engine Oil

Refer to the Operator's Manual, Checking Oil Level.

## Check Lubrication

Refer to the Operator's Manual, Greasing and Lubrication.

## Check Safety System

Refer to the Operator's Manual, Checking Safety System.

## Test Drive the Tractor

Ensure all electrical and mechanical systems are operating properly.

# Contents

	Page		Page
Safety .....	2	Attachment Lift Lever .....	17
Safe Operating Practices .....	2	Adjusting Dial-A-Height .....	17
Slope Chart .....	5	Positioning the Seat .....	18
Gasoline and Oil .....	8	Headlights .....	18
Recommended Gasoline .....	8	Positioning the Tilt Steering Wheel .....	18
Stabilizer/Conditioner .....	9	Maintenance .....	19
Filling the Fuel Tank .....	9	Service Interval Chart .....	19
Check Engine Oil Level .....	9	Air Cleaner .....	20
Operation .....	10	Engine Oil .....	22
Think Safety First .....	10	Spark Plug .....	24
Controls .....	10	Greasing and Lubrication .....	25
Key Choice Switch .....	10	Tire Pressure .....	26
Parking Brake .....	10	Brake .....	27
Starting and Stopping the Engine .....	11	Fuel Tank .....	28
Operating the Power Take Off (PTO) .....	12	Fuel Filter .....	29
The Safety Interlock System .....	13	Front Wheel Toe-In .....	30
Operating—in—Reverse .....	13	Fuse .....	31
Indicator Control Module .....	15	Headlights .....	32
Hourmeter .....	15	Battery .....	33
Driving Forward or Backward .....	15	Wiring Diagram .....	36
Selecting Ground Speeds .....	16	Cleaning and Storage .....	37
Stopping the Machine .....	16	Troubleshooting .....	39
		Warranty .....	Back Cover

**The enclosed Engine Owner's Manual is supplied for information regarding The U.S. Environmental Protection Agency (EPA) and the California Emission Control Regulation of emission systems, maintenance and warranty.**

**Keep this engine Owner's Manual with your unit. Should this engine Owner's Manual become damaged or illegible, replace immediately. Replacements may be ordered through the engine manufacturer.**

# Safety

**This machine meets or exceeds the B71.1-1998 specifications of the American National Standards Institute, in effect at the time of production. However, improper use or maintenance by the operator or owner can result in injury. To reduce the potential for injury, comply with these safety instructions and always pay attention to the safety alert  symbol, which means CAUTION, WARNING, or DANGER—"personal safety instruction." Failure to comply with the instruction may result in personal injury or death.**

## Safe Operating Practices

This product is capable of amputating hands and feet and throwing objects. Always follow all safety instructions to avoid serious injury or death.

### General Operation

1. Read, understand, and follow all instructions in the operator's manual and on the machine before starting.
2. Allow only responsible adults who are familiar with the instructions to operate the machine.
3. Clear the area of objects such as rocks, toys, wire, etc., which could be picked up and thrown by the blade.
4. Be sure the area is clear of other people before mowing. Stop the machine if anyone enters the area.
5. Never carry passengers.
6. Do not mow in reverse unless absolutely necessary. Always look down and behind before and while backing.
7. Be aware of the mower discharge direction and do not point it at anyone. Do not operate the mower without either the entire grass catcher or the guard in place.
8. Slow down before turning.
9. Never leave a running machine unattended. Always turn off blades, set parking brake, stop engine, and remove keys before dismounting.
10. Turn off blades when not mowing.
11. Stop the engine before removing the grass catcher or unclogging the chute.
12. Mow only in daylight or good artificial light.
13. Do not operate the machine while under the influence of alcohol or drugs.
14. Watch for traffic when operating near or crossing roadways.
15. Use extra care when loading or unloading the machine into a trailer or truck.
16. Always wear safety goggles or safety glasses with side shields when operating mower.
17. Data indicates that operators, age 60 years and above, are involved in a large percentage of riding mower-related injuries. These operators should evaluate their ability to operate the riding mower safely enough to protect themselves and others from serious injury.

## Slope Operation

Slopes are a major factor related to loss-of-control and tip-over accidents, which can result in severe injury or death. All slopes require extra caution. If you cannot back up the slope or if you feel uneasy on it, do not mow it.

- Mow up and down slopes, not across.
- Remove obstacles such as rocks, tree limbs, etc.
- Watch for holes, ruts or bumps. Uneven terrain could overturn the machine. Tall grass can hide obstacles.
- Use slow speed. Choose a low gear so that you will not have to stop or shift while on the slope.
- Follow New Holland's recommendations for wheel weight or counterweights to improve stability.
- Use extra care with grass catchers or other attachments. These can change the stability of the machine.
- Keep all movement on slopes slow and gradual. Do not make sudden changes in speed or direction.
- Avoid starting or stopping on a slope. If tires lose traction, disengage the blades and proceed slowly straight down the slope.
- Do not turn on slopes unless necessary, and then, turn slowly and gradually downhill, if possible.
- Do not mow near drop-offs, ditches, or embankments. The machine could suddenly turn over if a wheel goes over the edge of a cliff or ditch, or if an edge caves in.
- Do not mow on wet grass. Reduced traction could cause sliding.
- Do not try to stabilize the machine by putting your foot on the ground.
- Do not use a grass catcher on steep slopes.

## Children

Tragic accidents can occur if the operator is not alert to the presence of children. Children are often attracted to the machine and the mowing activity. Never assume that children will remain where you last saw them.

1. Keep children out of the mowing area and under the watchful care of another responsible adult.
2. Be alert and turn the machine off if children enter the area.
3. Before and while backing, look behind and down for small children.
4. Never carry children, even with the blades off. They may fall off and be seriously injured or interfere with safe machine operation.
5. Never allow children to operate the machine.
6. Use extra care when approaching blind corners, shrubs, trees, the end of a fence or other objects that may obscure vision.

## Service

1. Use extra care when handling gasoline and other fuels. They are flammable and vapors are explosive.
  - A. Use only an approved container.
  - B. Never remove the gas cap or add fuel when the engine is running. Allow the engine to cool before refueling. Do not smoke.
  - C. Never refuel the machine indoors.
  - D. Never store the machine or fuel container inside where there is an open flame, such as near a water heater or furnace.
2. Never run a machine inside a closed area.
3. Keep nuts and bolts tight, especially the blade attachment bolts. Keep equipment in good condition.

Thank you so much for reading.  
Please click the “Buy Now!”  
button below to download the  
complete manual.



After you pay.

You can download the most  
perfect and complete manual in  
the world immediately.

Our support email:

[ebooklibonline@outlook.com](mailto:ebooklibonline@outlook.com)