

NEW HOLLAND

Series 759C

Backhoe

OPERATOR'S

MANUAL



CONTENTS

	Page
INTRODUCTION	4
SAFETY PRECAUTIONS	5
OPERATION	6-12
Pre-Operation Check List	6
Operating Directions	6
Engine Speed	6
Controls	6
Boom / Swing	6
Dipperstick / Bucket	7
Left Hand Stabilizer	7
Right Hand Stabilizer	7
Operating the Backhoe	7
Transporting the Backhoe	8
Placing the Stabilizers	8
Filling the Bucket	9
Dumping the Bucket	9
Trenching Between a Building and Open Excavations	9-10
Side Slope Excavating or Trenching	10
Miscellaneous	10
Finishing Straight Walls	11
Backfilling	11
Seat Adjustment	11
Swing Lock	12
Boom Lock	12
Transporting Backhoe	12
Removal From Tractor and Storage	12
SERVICE	13-14
Beginning of Season	13
Hydraulic Hoses	13
Hydraulic System Reservoir	13
Bucket Tooth Points	14
Tightening Nuts and Bolts	14
Lubrication	14
HYDRAULIC TROUBLE SHOOTING	15-16
CYLINDER SERVICE	17
VALVE SERVICE	18-20
Backhoe Control Valve Illustration & Parts List	19
Replacing Sections	19
Replacing Section Seals	19
Spool Seal Removal	19
Spool Seal Installation	20
Replacing Damaged Backup Rings	20
Installing Spring Centering Spool Positioner Kit and Float Positioner Kit	20
Replacing Spool Ends	20
Relief Valve Cartridge Table	20
PARTS ILLUSTRATIONS	21-26
Mainframe	21
Swing Frame	22
Boom	23
Dipperstick	24
Seat	25
Hydraulics	26
Optional 3-point Link Kit	27
Optional Hydraulic Pump Kit	28
SPECIFICATIONS	29-31
SAFETY DECALS	32

INTRODUCTION

This manual provides operation, maintenance, assembly and parts identification for your new backhoe.

Your New Holland 759C backhoe is designed for use on New Holland TC48DA, TC55DA, TNA, TSA, and TLA tractors.

Successful operation and long life of your backhoe depends, of course, on proper operation and the care given it. Please read this manual carefully and follow all instructions. Correct operation and maintenance will save much time and expense.



This SAFETY ALERT SYMBOL identifies IMPORTANT SAFETY MESSAGES in this manual. OBSERVE and FOLLOW all SAFETY MESSAGES to prevent personal INJURY.

Reference to left and right used in this manual refer to the position when seated in the operating position on the backhoe, unless otherwise specified.

If at any time you have a service problem with your backhoe, or need parts, contact your local New Holland equipment dealer.

Your dealer will need your backhoe model, serial number and component number* to give you prompt efficient service. Record your serial and component numbers below. Also record date of purchase.

	CNH America LLC Racine, WI 53404 U.S.A.
NEWHOLLAND®	Made In U.S.A.
○ Model Number	759C ○
Product Identification Number	

* Your backhoe serial and component numbers are stamped on this plate located on right side of main frame.

DATE PURCHASED _____

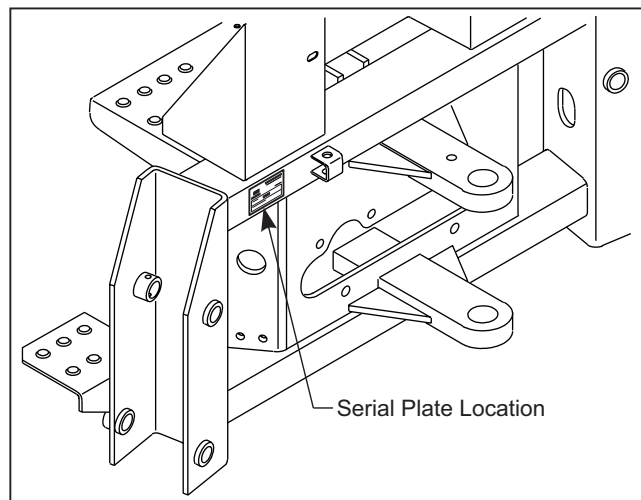

SAFETY PRECAUTIONS

Following are precautions suggested to help prevent accidents.

A careful operator operates best. Most accidents can be avoided by observing certain precautions. Read all precautions that follow before operating your tractor and loader to help prevent accidents. Equipment should be operated only by those who are responsible and instructed to do so.

GENERAL

1. Read your Operator's Manuals carefully before using tractor, backhoe or loader. Lack of operating knowledge can lead to accidents.
2. Replace damaged or illegible safety decals. See page 32 for required decals.
3. Operate tractor, loader and backhoe only from operator's seat.

TRACTOR

1. Use of seat belt is recommended. Overturning a tractor without use of a seat belt can result in death or injury.
2. Add recommended wheel ballast and/or rear weight as recommended in owner's manual to provide good stability.
3. Move rear wheels to widest settings recommended by New Holland to increase stability.
4. Do not start the engine or operate controls while standing beside the tractor. Always sit in the tractor seat when starting the engine or operating controls.
5. Do not park the tractor on a steep incline.
6. Move and turn tractor at low speeds.

BACKHOE

1. Never allow anyone to get under the backhoe bucket when the bucket is raised.
2. To prevent upsets, avoid full reach and swinging the backhoe bucket to the downhill side when operating on a slope.
3. Watch out for overhead and underground high-voltage electrical lines when operating the backhoe.
4. Do not enter the platform from the rear.
5. Always attach the backhoe transport locks before transporting the unit.
6. Always place the tractor transmission in neutral before operating backhoe.

BACKHOE / LOADER OPERATION

1. Always be sure of water, gas, sewage and electrical line locations before you start to dig. **Call 888-258-0808 for location of utilities.**
2. Watch out for overhead and underground high-voltage electrical lines when operating the loader or backhoe.
3. Operate the loader or backhoe controls only when properly seated at the controls.
4. Never attempt to lift loads in excess of loader or backhoe capacity.

5. Always lower the loader and backhoe buckets to the ground, shut off the engine and apply the parking brake before getting off the unit.
6. Always be watchful of bystanders when operating the loader, when lowering the stabilizers, or when operating the backhoe.
7. Use care when operating on steep grades to maintain proper stability. Always carry the bucket as low as possible.
8. Never attach chains, ropes, cables, etc. to the loader or backhoe for pulling purposes.

LOADER

1. Do not transport anyone in the loader bucket.
2. Always carry the loader bucket low for maximum stability and visibility, whether the bucket is loaded or empty.
3. Always use the recommended amount of counterweighting to ensure good stability.
4. Be careful when handling round objects such as round bales, poles, etc. Lifting too high or rolling bucket too far back could result in these objects rolling rearward down the loader arms on the operator.
5. Never allow anyone to get under the loader bucket or reach through the lift arms when the bucket is raised.
6. Exercise caution when operating the loader with a raised bucket or fork.

MAINTENANCE

1. When servicing or replacing pins in cylinder ends, buckets, etc., always use a drift and hammer of non-sparking material. Failure to do so could result in injury from flying metal fragments.
2. Do not modify or alter or permit anyone else to modify or alter backhoe or any of its components or any backhoe function without first consulting a New Holland Dealer. If you have any questions regarding backhoe modifications contact New Holland North America.
3. Always wear safety goggles when servicing or repairing backhoe, tractor or loader.
4. Escaping hydraulic/diesel fluid under pressure can penetrate skin causing serious personal injury.
 - DO NOT use your hand to check for leaks. Use a piece of cardboard or paper to search for leaks.
 - Stop engine and relieve pressure before connecting or disconnecting hydraulic or diesel lines.
 - Tighten all connections before starting engine or pressurizing lines.If any fluid is injected into skin, obtain medical attention immediately or gangrene may result.
5. Do not tamper with relief valve setting. Valve relief is factory-set. Changing relief setting can cause overloading and serious operator injury may result.

Whenever you see this symbol



it means:

ATTENTION!

BECOME ALERT!

YOUR SAFETY IS INVOLVED!

OPERATION



CAUTION: To avoid possible injury, observe the following safety rules BEFORE OPERATING backhoe.

- Be sure area is clear of underground utilities or other hazards.
- Position a barricade around work area.
- Provide adequate front end weight to counter balance backhoe at all times.
- Keep bystanders a safe distance away.

PRE-OPERATION CHECK LIST

This backhoe is designed for safety, durability and operator convenience. To insure satisfactory performance complete the following check list and make all necessary adjustments before initial operation.

1. All safety shields must be in place.
2. Safety and operation decals must be in place, undamaged and clean.
3. Hydraulic hookup must be correct and all connections tight.

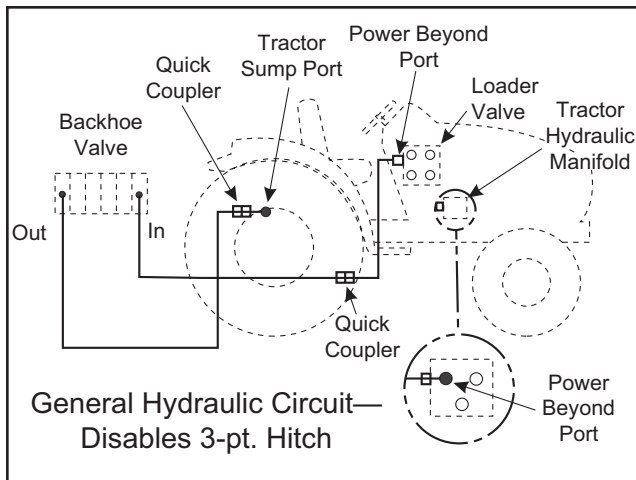

4. All bolts and pins which attach backhoe to tractor must be in place. Check tightness of bolts and check that all pins are retained.
5. Tractor must be in proper operating condition.
6. Lubricate backhoe, see "SERVICE".
7. Controls must operate properly according to lever operation diagrams on backhoe decals. Refer lever operation diagrams, which are also shown in "OPERATING BACKHOE" on the following page.
8. Cycle all cylinders slowly to purge air from hydraulic system.
9. Hydraulic system oil level must be correct.

OPERATING DIRECTIONS

The terms right, left, front and back shall be from the position of the operator when seated in the operating position on the backhoe.

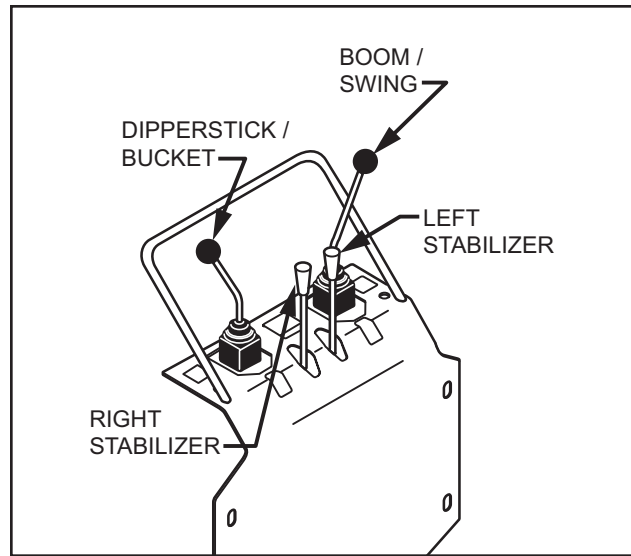

ENGINE SPEED

Speed at which backhoe operates is partially dependent on engine RPM. Use a moderate engine speed to start and increase it as your experience permits.

CONTROLS

The backhoe has two major control levers, Boom/Swing and Dipperstick/Bucket. These controls are located on the control panel directly ahead of the operator.

The stabilizer control levers are located between the two major control levers.

Direction of movement of operation corresponds to movement of operating lever.

BOOM/SWING

Push lever forward, boom moves down, away from operator. Pull lever back, boom moves up, toward operator.

Pushing lever farther forward into detent position puts boom into "float."

Move lever to left, backhoe swings to left. Move lever to right, backhoe moves right.

By moving lever to one of the intermediate positions, boom can be swung left or right at the same time as it is being raised or lowered, performing two operations simultaneously.

Swing left and lower boom by moving control lever forward and to the left.

Swing left and raise boom by moving control lever back and to the left.

Swing right and lower boom by moving control lever forward and to the right.

Swing right and raise boom by moving control lever back and to the right.

OPERATION

DIPPERSTICK/BUCKET

Push lever forward, dipperstick moves away from operator.
Pull lever back, dipperstick moves toward operator.

Move lever to left, bucket curls in. Move lever right, bucket extends out.

By moving lever to one of the intermediate positions, dipperstick can be extended or retracted at the same time as bucket is being loaded or dumped.

Extend and load bucket by moving lever forward and to the left.

Retract and load bucket by moving lever back and to the left.

Extend and dump bucket by moving lever forward and to the right.

Retract and dump bucket by moving lever back and to the right.

The two operations of the boom lever combined with the two operations performed by bucket and dipperstick control levers provide four simultaneous operations from the two levers. Oil flow will go to the operation which requires the least pressure. The ability to feather valve spools and balance pressure comes with experience, and will result in reduced cycle times.

LEFT HAND STABILIZER

Push lever forward, left hand stabilizer lowers. Pull lever back, left hand stabilizer raises.

RIGHT HAND STABILIZER

Push lever forward, right hand stabilizer lowers. Pull lever back, right hand stabilizer raises.

OPERATING BACKHOE

CAUTION: To avoid possible injury, observe the following safety rules WHEN OPERATING backhoe.

- Operate from backhoe operators seat only.
- Lower stabilizers until rear of tractor is totally supported by them.
- Do not dig near stabilizers.
- Do not attempt to raise tractor off ground or move tractor forward or backward using backhoe dipperstick or bucket.
- Do not lose stability by swinging bucket downhill when positioned on a slope.

It is not difficult to become an efficient operator. Control operating decals are located beside control levers. Study these decals. They will assist you in becoming familiar with the controls.

Smooth, light handling of the controls will result in the most efficient backhoe operation.

Operate the backhoe control levers to become familiar with their speed and movements. Engine speed will determine speed of cylinder operation.

Swing the boom several times to practice controlling the speed of swing. Do not operate swing more than 45 degrees each way for the first few times. Gradually increase the arc.

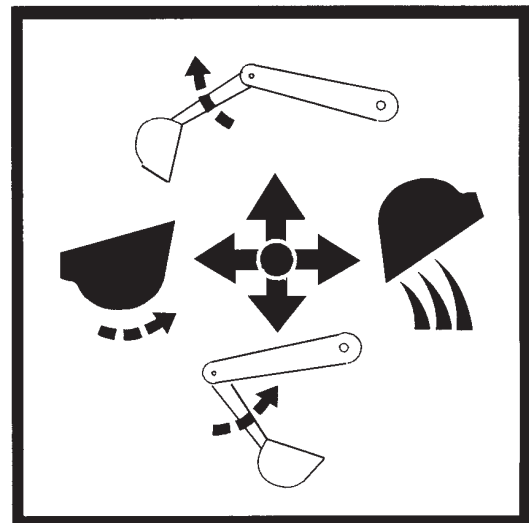
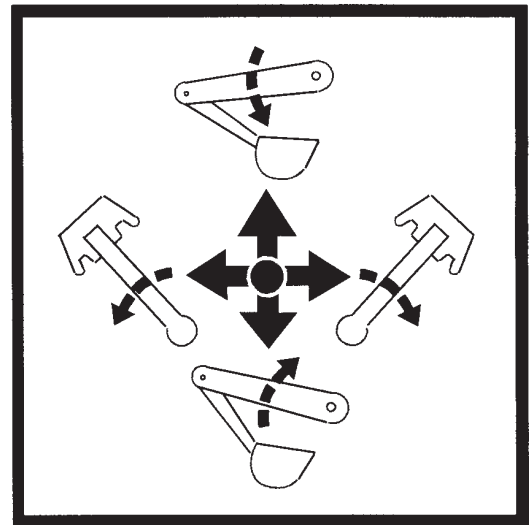

Best results are obtained by digging near the center of the swing arc so material can be dumped on either side.

As operator becomes more familiar with operation of backhoe, it will be common practice to operate two controls at one time. For example with the bucket extended and the dipperstick extended, the lift control and dipperstick control can be operated together to bring bucket toward operator with down pressure on it. As dipperstick approaches operator, the dipperstick and bucket controls can be operated together to close bucket and trap material. At the end of the stroke, lift and dipperstick controls are operated to move the load up and away from the operator to save time in clearing the excavation.

This dual operation of controls will speed and simplify the digging operation. Normally the two or more movements will not be equal or even simultaneous but as pressure within the cylinders, and the resistance of an operating member of the hoe lessens, it will begin to move. It is balancing the force of one member against the other.

NOTE: Actuating the bucket is the key to powerful digging. Operating the dipperstick and bucket controls simultaneously will insure a full bucket and prevent wasted motion and time.

Thank you so much for reading.
Please click the “Buy Now!”
button below to download the
complete manual.



After you pay.

You can download the most
perfect and complete manual in
the world immediately.

Our support email:

ebooklibonline@outlook.com