

**220, 222, 224,
444 and 446
Tractors**

Operator's Manual

9-4393

Reprinted







THIS SAFETY ALERT SYMBOL INDICATES IMPORTANT SAFETY MESSAGES IN THIS MANUAL. WHEN YOU SEE THIS SYMBOL, CAREFULLY READ THE MESSAGE THAT FOLLOWS AND BE ALERT TO THE POSSIBILITY OF PERSONAL INJURY OR DEATH.

M171B

If Safety Decals on this machine use the words **Danger, Warning or Caution**, which are defined as follows:

- **DANGER:** Indicates an immediate hazardous situation which if not avoided, will result in death or serious injury. The color associated with Danger is RED.
- **WARNING:** Indicates an potentially hazardous situation which if not avoided, will result in serious injury. The color associated with Warning is ORANGE.
- **CAUTION:** Indicates an potentially hazardous situation which if not avoided, may result in minor or moderate injury. It may also be used to alert against unsafe practices. The color associated with Caution is YELLOW.

If Safety Decals on this machine are ISO two panel Pictorial, decals are defined as follows:

- The first panel indicates the nature of the hazard.
- The second panel indicates the appropriate avoidance of the hazard.
- Background color is YELLOW.
- Prohibition symbols such as   and  if used, are RED.



WARNING

IMPROPER OPERATION OF THIS MACHINE CAN CAUSE INJURY OR DEATH. BEFORE USING THIS MACHINE, MAKE CERTAIN THAT EVERY OPERATOR:

- Is instructed in safe and proper use of the machine.
- Reads and understands the Manual(s) pertaining to the machine.
- Reads and understands ALL Safety Decals on the machine.
- Clears the area of other persons.
- Learns and practices safe use of machine controls in a safe, clear area before operating this machine on a job site.

It is your responsibility to observe pertinent laws and regulations and follow Case Corporation instructions on machine operation and maintenance.



**220, 222, 224,
444 and 446 Tractors
Operator's Manual No. 9-4393**

J I Case
A Tenneco Company





WARNING!



Improper operation of this machine may result in injury or death. Before operating this machine study the SAFETY RULES starting on page 2 and read this Warning Statement thoroughly.



Look for this symbol which points out important safety precautions. It means ATTENTION! BECOME ALERT! YOUR SAFETY IS INVOLVED!

NOTE

THIS MANUAL APPLIES TO THE FOLLOWING TRACTORS

Model	Serial number and after
220	9656747
222	9658189
224	9667000
444	9661261
446	9668000

To insure efficient and prompt service, please furnish us with the Model, Serial, Engine Model Numbers and Engine Specification Number of your Tractor in all correspondence or contacts.

KLTWO

PRICE \$.75

Printed in USA

TO THE PURCHASER OF A CASE TRACTOR

The care you give your new Case Tractor will greatly determine the satisfaction and service life you will obtain from it. Use this manual as your guide. By observing the instructions and suggestions in this manual, your Case Tractor will serve you well for many years.

As an Authorized Case Dealer, we stock Genuine Case Parts, which are manufactured with the same precision and skill as the original equipment. Our factory trained staff is kept well informed on the best methods of servicing Case equipment and is ready and able to help you.

Should you require additional aid or information, contact us.

Your Authorized Case Dealer

- NOTICE -

Laws of some states or provinces may require that this unit be equipped with a SPARK ARRESTOR OR SPARK ARRESTING MUFFLER. The State of California, as an example, is one state which has such regulations for agricultural and forestry applications, plus a regulation for construction applications in forest-covered, brush-covered, or grass-covered lands.

Typically such laws and regulations require spark arresting devices to be maintained in good working order and typically to be attached to the exhaust system on naturally aspirated engines (engines without a turbo charger).



**CAUTION:
SAFETY PRECAUTIONS
READ CAREFULLY**

1. BECOME THOROUGHLY FAMILIAR WITH ALL TRACTOR AND ATTACHMENT CONTROLS BEFORE OPERATING.
2. Stop and inspect the mower for damage immediately after striking a foreign object and repair damage before restarting and operating the machine.
3. Never operate any of the controls from any position but seated
4. Be extra careful when going down grades.
5. Drive at a speed slow enough to insure safety and complete control at all times.
6. Reduce ground speed when making a turn, going down hill or applying the brake.
7. Always operate the tractor in low range whenever on hills or inclines. Always drive in a forward motion while proceeding down hill and, if necessary, back up a slope to the desired position.
8. Never leave the tractor parked unattended on hills or inclines.
9. Never leave the engine running while it is unattended.
10. Never dismount from a tractor when it is in motion.
11. Never permit persons other than the operator to ride on the tractor.
12. Never stand between a tractor and machine when hitching unless the transmission is in NEUTRAL, the parking brake is set and the engine is stopped.
13. DO NOT OIL, GREASE OR ADJUST A TRACTOR WHEN THE ENGINE IS RUNNING.
14. Never refuel a tractor when the engine is running.
15. Do not smoke when refueling.
16. Never operate a tractor in a closed shed or garage.
17. Do not wear loose fitting clothing which may catch in the moving parts.
18. To prevent highway accidents, use red warning flags in the daytime and red warning lamps at night.
19. Always have PTO lever disengaged and the clutch brake pedal depressed and locked when parking or starting the tractor.
20. REMEMBER, A CAREFUL OPERATOR IS ALWAYS THE BEST INSURANCE AGAINST AN ACCIDENT.

CAUTION
 KEEP ALL SHIELDS IN PLACE.
 BEFORE STARTING ENGINE: DISENGAGE ATTACHMENT DRIVE AND PLACE TRAVEL CONTROL LEVER INTO NEUTRAL.
 TO PARK TRACTOR: PLACE TRAVEL CONTROL LEVER INTO NEUTRAL, SET PARKING BRAKE, DISENGAGE ATTACHMENT DRIVE, SHUT OFF ENGINE AND REMOVE IGNITION KEY.

CAUTION: WHEN OPERATING ON INCLINE, PLACE TRANSMISSION IN LOW RANGE.
 STOP ENGINE AND WAIT FOR ALL MOVEMENT TO STOP BEFORE DISMOUNTING TRACTOR, BEFORE SERVICING OR MAKING ADJUSTMENTS TO TRACTOR AND/OR ATTACHMENTS.
 KEEP PEOPLE AND PETS A SAFE DISTANCE AWAY FROM THE MACHINE.

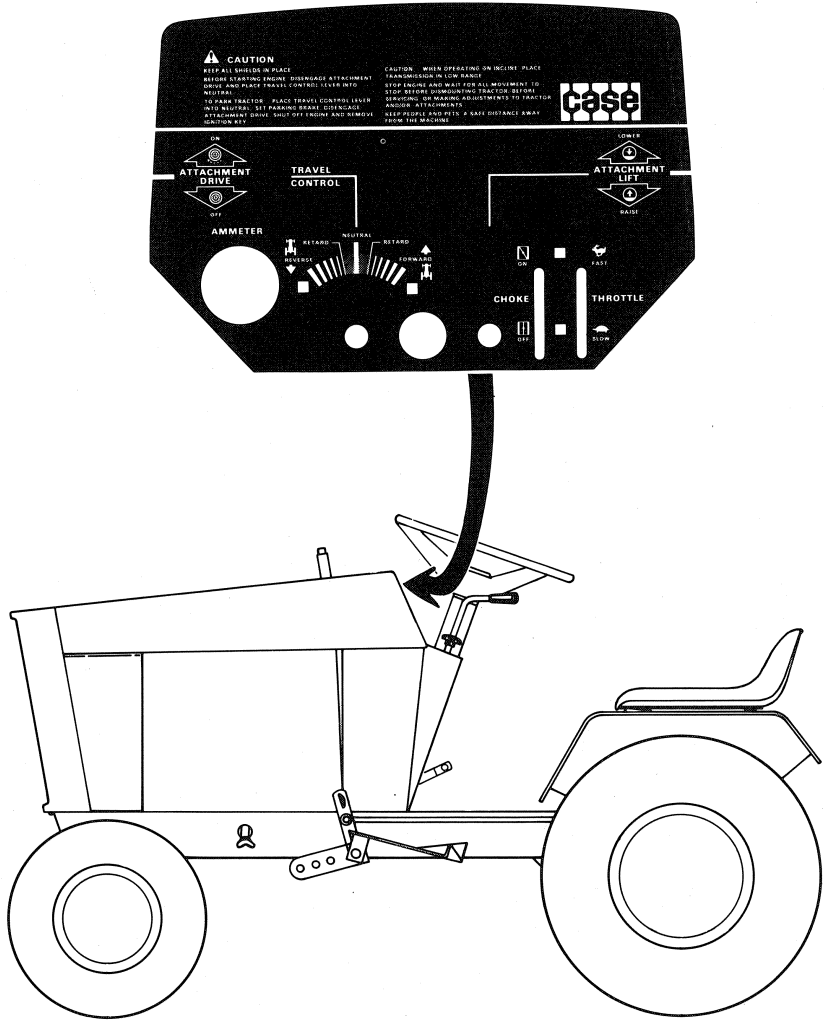

Read and observe the cautions on the tractor instrument panel decal.



Figure 1. Left Hand View of Case 220 Compact Tractor.

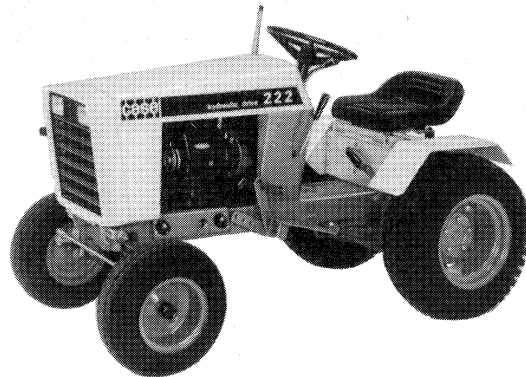

Figure 2. Left Hand View of Case 222 Compact Tractor.



Figure 3. Right Hand View of Case 224 Compact Tractor.



Figure 4. Left Hand View of Case 444 Compact Tractor.



Figure 5. Right Hand View of Case 446 Compact Tractor.

Buy Now



Our support email:

ebooklibonline@outlook.com