



Service Manual

500 Series

From m/c No. 561001

PUBLISHED BY THE TECHNICAL PUBLICATIONS DEPARTMENT OF
JCB SERVICE; © ROCESTER, STAFFORDSHIRE, ST14 5LS, ENGLAND
Tel. ROCESTER (01889) 590312 PRINTED IN ENGLAND

Publication No. 9803/3600

Contents

This Service Manual covers the following Machines:-

525-58 and 525-58 Farm Special - from machine Serial Number 561001
525-67 and 525-67 Farm Special - from machine Serial Number 561001
525-58 and 525-67 Farm Special Plus
525-58 and 525-67 Basic Servo Options
527-58 and 527-67 - from machine Serial Number 572775
530-95 - from machine Serial Number 564980
530-110 - from machine Serial Number 563359
530-110 and 530-120 - PlaceAce
530-110 and 530-120 Servo Options
530-120 - from machine Serial Number 562601
530-67 and 530-67 Farm Special - from machine Serial Number 571001
535-67 - from machine Serial Number 572775
* 537-120 and 537-130 from machine Serial Number 572900

Information covers two stage and three stage boom machines.

General	1
Hydraulics	2
Body and Framework	3
PlaceAce Control System	4
Servo Control System	4A
Engine	5
Transmission	6
Axles	7
Brakes	8
Hydraulic Steering	9
Electrics	10
Service Tools	11
Index	

Contents

Introduction

This publication is designed for the benefit of JCB Distributor Service Engineers who are receiving, or have received, training by JCB Technical Training Department.

It is assumed that these personnel have a sound knowledge of workshop practice, safety procedures, and general techniques associated with the maintenance and repair of hydraulic earthmoving equipment. Therefore these basic subjects generally are omitted from this manual, the intention being to convey only more specialised information concerning particular aspects of a machine or component.

For example, renewal of oil seals, gaskets, etc., and any component showing obvious signs of wear or damage is expected as a matter of course, and therefore information of this nature is included only in the context of specialised procedures or where a range of wear tolerances is required. Similarly, it is expected that components will be cleaned and lubricated where appropriate, also that any opened hose or pipe connections will be blanked to prevent excessive loss of hydraulic fluid and ingress of dirt.

For convenience this manual is compiled in sections, e.g. "Hydraulics", "Electrics", etc. but, to find details of a specific component, reference should be made to the alphabetical index at the back of the book.

Illustrations which show a dismantled component are numbered as a guide to the dismantling sequence, which generally can be reversed for assembly.

Torque settings are given as a 'mean' figure which may be varied by plus or minus 3%. Torque figures indicated are for dry threads, hence for lubricated threads may be reduced by one third. Where no figure is quoted in the text, refer to page 1/1 - 3.

'Left Hand' and 'Right Hand' are as viewed from the rear of the machine looking forward.

WARNING **Asbestos**

Asbestos dust can damage your lungs. Some engine joints and gaskets may contain asbestos. Take the following precautions when working on them.

- 1 Wear a face mask and gloves.
- 2 Work in a well ventilated area and do not smoke.
- 3 Do not use a rotary wire brush, use a hand scraper.
- 4 Make sure the material to be removed is wet with oil or water to contain loose particles.
- 5 Place all material into plastic bags and dispose in accordance with local regulations.

GEN-1-8

WARNING **Fluoroelastomeric Materials**

Certain seals and gaskets (e.g. crankshaft oil seal) on JCB machines contain fluoroelastomeric materials such as Viton, Fluorel and Technoflon. Fluoroelastomeric materials subjected to high temperatures can produce highly corrosive hydrofluoric acid. **THIS ACID CAN SEVERELY BURN.**

New fluoroelastomeric components at ambient temperature require no special safety precautions.

Used fluoroelastomeric components whose temperatures have not exceeded 300°C require no special safety precautions. If evidence of decomposition (e.g. charring) is found, refer to the next paragraph for safety instructions **DO NOT TOUCH COMPONENT OR SURROUNDING AREA.**

Used fluoroelastomeric components subjected to temperatures greater than 300°C (e.g. engine fire) must be treated using the following safety procedure. Make sure that heavy duty gloves and special safety glasses are worn:

- 1 Ensure that components have cooled then remove and place material into plastic bags.
- 2 Thoroughly wash contaminated area with 10% calcium hydroxide or other suitable alkali solution, if necessary use wire wool to remove burnt remains.
- 3 Thoroughly wash contaminated area with detergent and water.
- 4 Contain all removed material, gloves etc. used in this operation in sealed plastic bags and dispose of in accordance with Local Authority Regulations.







DO NOT BURN FLUOROELASTOMERIC MATERIALS.

If contamination of skin or eyes occurs, wash the affected area with a continuous supply of clean water or with calcium hydroxide solution for 15-60 minutes. Get medical attention immediately.

INT-3-3-5/1

Colour Coding

The following colour coding, used on illustrations to denote various conditions of oil pressure and flow, is standardised throughout JCB Service publications.

	Red	— Full Pressure Pressure generated from operation of a service. Depending on application this may be anything between neutral circuit pressure and M.R.V. operating pressure.
	Pink	— Pressure Pressure that is above neutral circuit pressure but lower than that denoted by red.
	Orange	— Servo Oil pressure used in controlling a device (servo).
	Blue	— Neutral Neutral circuit pressure.
	Green	— Exhaust
	Light Green	— Cavitation Oil subjected to a partial vacuum due to a drop in pressure (cavitation).
	Yellow	— Lock Up Oil trapped within a chamber or line, preventing movement of components (lock up).

A390940

Contents	Page No.
Fluids, Lubricants, Capacities & Specifications	
- 525-58/67, 527-58/67 & 530-95	1 - 1
- 530-110	1 - 2
* - 530-120, 537-120 & 537-130	1 - 2A
- 525-58 Farm Special Plus 530-67 & 535-67	1 - 2B
- Torque Settings	1 - 3
- Identifying Your Machine	1 - 4
Service Schedules	2 - 1
Greasing	
Pivot Pins	
- 525-58/67, 527-58/67, 530-67 & 535-67	3 - 1
- 530-120	3 - 2
- 530-110	3 - 3
- 530-95	3 - 4
Front Axle	3 - 5
Rear Axle	3 - 6
Carriage Lock Pins	3 - 7
Boom Wear Pad Runways	3 - 8
Extension Ram Pivots	
- 525-58/67, 527-58/67, 530-67/95 & 535-67	3 - 9
- 530-120	3 - 10
- 530-110	3 - 11
Oiling	3 - 12
Boom Safety Strut	4 - 1

FLUIDS, LUBRICANTS, CAPACITIES AND SPECIFICATIONS (525-58, 67, 527-58, 67, 530-95)

Note: New engines DO NOT require a running-in period. The engine/machine should be used in a normal work cycle immediately; glazing of the piston cylinder bores, resulting in excessive oil consumption, could occur if the engine is gently run-in. Under no circumstances should the engine be allowed to idle for extended periods; (e.g. warming up without load). Engines of new machines are filled at the factory with JCB 10W/30 Multigrade oil. This oil should be drained after the first 100 hours operation and the engine filled with the appropriate recommended grade as shown in the lubrication chart. JCB 10W/30 Multigrade should also be used for the first 100 hours operation whenever a new or reconditioned engine is fitted to the machine. After the first 100 hours operation, it is essential that the 10W/30 oil is replaced by the lubricant recommended below.

ITEM	CAPACITY Litres (Gal)	FLUID/LUBRICANT	INTERNATIONAL SPECIFICATION
Fuel Tank	90 (20)	Diesel Oil (See Types of Fuel)	ASTM D975-66T Nos. 1D, 2D
Engine (Oil)	10 (2.2)	JCB 15W/40 Multigrade -10 °C to 50 °C (14 °F to 122 °F) JCB Super Universal Agricultural -15 °C to 30 °C (5 °F to 86 °F) JCB Torque Converter Fluid -18 °C to 0 °C (0 °F to 32 °F)	SAE15W/40, MIL-L-46152B, API CD/SE, MIL-L-2104 SAE10W/30, MIL-L-2105, MIL-L-46152 API CD/SE, MIL-L-2104C SAE10W, MIL-L-46152, MIL-L-2104D API CD/SE
Engine (Coolant)	17 (3.7)	JCB Universal Antifreeze/water (See Coolant Mixtures)	ASTM D3306-74
Gearbox Syncro Shuttle Powershift	18.25 (4.0) †15.0 (3.3)	JCB Special Transmission Fluid JCB Special Transmission Fluid	ESP-M2C 33G ESP-M2C 33G
Front Axle Housing Hubs (x2)	18 (3.9) 2.0 (0.4)	JCB Special Gear Oil JCB Special Gear Oil	ESEN-M2C 86A/B ESEN-M2C 86A/B
Rear Axle * Housing * Hubs (x2)	13 (2.8) 2.0 (0.4)	JCB Special Gear Oil JCB Special Gear Oil	ESEN-M2C 86A/B ESEN-M2C 86A/B
Brake System		JCB Light Hydraulic Fluid DO NOT USE ORDINARY BRAKE FLUID	ISO VG15
Hydraulic Tank	*152 (33.5)	JCB High Performance Hydraulic Oil (Above 38 °C, 100 °F) JCB Special Hydraulic Fluid (Below 38 °C, 100 °F)	ISO VG46 ISO VG32
Grease Points		JCB Special MPL Grease	Lithium based, No. 2 consistency
Wear Pad Runways		JCB Waxoyl	
Boom Hoses		JCB Special Slide Lubricant	

* **Note:** This is nominal machine capacity. The total hydraulic system capacity depends on the equipment being used. Fill with all rams closed. Watch level sight glass when filling.

† **Note:** This is a system capacity. Use the '**MIN**' and '**MAX**' marks on the dipstick when refilling the system.

Coolant Mixtures	%	Antifreeze	Starts to Freeze
	55	9.35 litres (2.04 gal)	-36° C (-33 °F)

FLUIDS, LUBRICANTS, CAPACITIES AND SPECIFICATIONS (530-110)

Note: New engines DO NOT require a running-in period. The engine/machine should be used in a normal work cycle immediately; glazing of the piston cylinder bores, resulting in excessive oil consumption, could occur if the engine is gently run-in. Under no circumstances should the engine be allowed to idle for extended periods; (e.g. warming up without load). Engines of new machines are filled at the factory with JCB 10W/30 Multigrade oil. This oil should be drained after the first 100 hours operation and the engine filled with the appropriate recommended grade as shown in the lubrication chart. JCB 10W/30 Multigrade should also be used for the first 100 hours operation whenever a new or reconditioned engine is fitted to the machine. After the first 100 hours operation, it is essential that the 10W/30 oil is replaced by the lubricant recommended below.

ITEM	CAPACITY Litres (Gal)	FLUID/LUBRICANT	INTERNATIONAL SPECIFICATION
Fuel Tank	90 (20)	Diesel Oil (See Types of Fuel)	ASTM D975-66T Nos. 1D, 2D
Engine (Oil) Engine Type: AA, AB, AR & AK Builds	10 (2.2)	JCB Super Multigrade 15W/40 -10°C to 50°C (14°F to 122°F) JCB Super Multigrade 10W/30 -15°C to 40°C (5°F to 104°F)	SAE15W/40 API CF4/SG SAE 10W/30 API CF4/SG
Engine Type: AA & AB Builds Only		JCB Super Universal Agricultural -15°C to 30°C (5°F to 86°F) JCB Torque Converter Fluid -18°C to 0°C (0°F to 32°F)	SAE10W/30 API CD/SE SAE10W API CD/SE
Engine (Coolant) System Antifreeze	18 (3.9) 10 (2.2)	JCB Four Seasons Antifreeze And Summer Coolant (See Coolant Mixtures)	ASTM D3306-74
Syncro Shuttle	18.25 (4.0)	JCB Special Transmission Fluid	ESP-M2C 33G
Axles Housing (Front) Housing (Rear) Hubs (x2)	18 (3.9) 13 (2.8) 2.0 (0.4)	JCB High Performance Gear Oil	API GL4
Brake System		JCB Light Hydraulic Fluid DO NOT USE ORDINARY BRAKE FLUID	ISO VG15
Hydraulic Tank (*)	190 (41.8)	JCB High Performance Hydraulic Oil (Above 38°C, 100°F) JCB Special Hydraulic Fluid (Below 38 °C, 100 °F) JCB Light Hydraulic Fluid (For Iceland, Norway, Sweden and Finland ONLY)	ISO VG46 ISO VG32 ISO VG15
Grease Points (**)		JCB HP Grease JCB Special MPL-EP Grease	Lithium complex NLGI No. 2 consistency including extreme pressure additives Lithium based NLGI No. 2 consistency including extreme pressure additives
Wear Pad Runways		JCB Waxoyl	
Boom Hoses		JCB Special Slide Lubricant	

(*) Note: This is nominal machine capacity. The total hydraulic system capacity depends on the equipment being used. Fill and check with all rams closed. Watch level sight glass when filling.

() Note:** If JCB MPL Grease is used, all 50 hour greasing operations must be carried out at TEN (10) HOUR intervals; all 500 hour greasing operations must be carried out at 50 HOUR intervals.

FLUIDS, LUBRICANTS, CAPACITIES AND SPECIFICATIONS
(530-120, 537-120 & 537-130)

Note: New engines DO NOT require a running-in period. The engine/machine should be used in a normal work cycle immediately; glazing of the piston cylinder bores, resulting in excessive oil consumption, could occur if the engine is gently run-in. Under no circumstances should the engine be allowed to idle for extended periods; (e.g. warming up without load). Engines of new machines are filled at the factory with JCB 10W/30 Multigrade oil. This oil should be drained after the first 100 hours operation and the engine filled with the appropriate recommended grade as shown in the lubrication chart. JCB 10W/30 Multigrade should also be used for the first 100 hours operation whenever a new or reconditioned engine is fitted to the machine. After the first 100 hours operation, it is essential that the 10W/30 oil is replaced by the lubricant recommended below.

ITEM	CAPACITY Litres (Gal)	FLUID/LUBRICANT	INTERNATIONAL SPECIFICATION
Fuel Tank	90 (20)	Diesel Oil (See Types of Fuel)	ASTM D975-66T Nos. 1D, 2D
Engine (Oil)	10 (2.2)	JCB 15W/40 Multigrade -10 °C to 50 °C (14 °F to 122 °F) JCB Super Universal Agricultural -15 °C to 30 °C (5 °F to 86 °F) JCB Torque Converter Fluid -18 °C to 0 °C (0 °F to 32 °F)	SAE15W/40, MIL-L-46152B, API CD/SE, MIL-L-2104 SAE10W/30, MIL-L-2105, MIL-L-46152 API CD/SE, MIL-L-2104C SAE10W, MIL-L-46152, MIL-L-2104D API CD/SE
Engine (Coolant)	23.5 (5.2)	JCB Universal Antifreeze/water (See Coolant Mixtures)	ASTM D3306-74
Syncro Shuttle	18.25 (4.0)	JCB Special Transmission Fluid	ESP-M2C 33G
* Front Axle Housing Hubs (x2)	17 (3.7) 2.0 (0.4)	JCB Special Gear Oil JCB Special Gear Oil	ESEN-M2C 86A/B ESEN-M2C 86A/B
* Rear Axle Housing Hubs (x2)	18 (3.9) 0.75 (0.16)	JCB Special Gear Oil JCB Special Gear Oil	ESEN-M2C 86A/B ESEN-M2C 86A/B
Brake System		JCB Light Hydraulic Fluid DO NOT USE ORDINARY BRAKE FLUID	ISO VG15
Hydraulic Tank	†292 (64.3)	JCB High Performance Hydraulic Oil (Above 38 °C, 100 °F) JCB HP32 (Below 38 °C, 100 °F)	ISO VG46 ISO 32
Grease Points		JCB Special MPL Grease	Lithium based, No. 2 consistency
Wear Pad Runways		JCB Waxoyl	
Boom Hoses		JCB Special Slide Lubricant	

† **Note:** This is nominal machine capacity. The total hydraulic system capacity depends on the equipment being used. Fill with all rams closed. Watch level sight glass when filling.

Coolant Mixtures	%	Antifreeze	Starts to Freeze
	55	12.92 litres (2.84 gal)	-36° C (-33 °F)

FLUIDS, LUBRICANTS, CAPACITIES AND SPECIFICATIONS (525-58 Farm Special Plus, 530-67, 535-67)

Note: New engines DO NOT require a running-in period. The engine/machine should be used in a normal work cycle immediately; glazing of the piston cylinder bores, resulting in excessive oil consumption, could occur if the engine is gently run-in. Under no circumstances should the engine be allowed to idle for extended periods; (e.g. warming up without load). Engines of new machines are filled at the factory with JCB 10W/30 Multigrade oil. This oil should be drained after the first 100 hours operation and the engine filled with the appropriate recommended grade as shown in the lubrication chart. JCB 10W/30 Multigrade should also be used for the first 100 hours operation whenever a new or reconditioned engine is fitted to the machine. After the first 100 hours operation, it is essential that the 10W/30 oil is replaced by the lubricant recommended below.

ITEM	CAPACITY Litres (Gal)	FLUID/LUBRICANT	INTERNATIONAL SPECIFICATION
Fuel Tank	90 (20)	Diesel Oil (See Types of Fuel)	ASTM D975-66T Nos. 1D, 2D
Engine (Oil)	10 (2.2)	JCB 15W/40 Multigrade -10 °C to 50 °C (14 °F to 122 °F) JCB Super Universal Agricultural -15 °C to 30 °C (5 °F to 86 °F) JCB Torque Converter Fluid -18 °C to 0 °C (0 °F to 32 °F)	SAE15W/40, MIL-L-46152B, API CD/SE, MIL-L-2104 SAE10W/30, MIL-L-2105, MIL-L-46152 API CD/SE, MIL-L-2104C SAE10W, MIL-L-46152, MIL-L-2104D API CD/SE
Engine (Coolant)	17 (3.7)	JCB Universal Antifreeze/water (See Coolant Mixtures)	ASTM D3306-74
Gearbox Syncro Shuttle Powershift	18.25 (4.0) †15.0 (3.3)	JCB Special Transmission Fluid JCB Special Transmission Fluid	ESP-M2C 33G ESP-M2C 33G
Front Axle Housing Hubs (x2)	18 (3.9) 2.0 (0.4)	JCB Special Gear Oil JCB Special Gear Oil	ESEN-M2C 86A/B ESEN-M2C 86A/B
Rear Axle * Housing * Hubs (x2)	13 (2.8) 2.0 (0.4)	JCB Special Gear Oil JCB Special Gear Oil	ESEN-M2C 86A/B ESEN-M2C 86A/B
Brake System		JCB Light Hydraulic Fluid DO NOT USE ORDINARY BRAKE FLUID	ISO VG15
Hydraulic Tank	††152 (34.5)	JCB High Performance Hydraulic Oil (Above 38 °C, 100 °F) JCB Special Hydraulic Fluid (Below 38 °C, 100 °F)	ISO VG46 ISO VG32
Grease Points		JCB Special MPL Grease	Lithium based, No. 2 consistency
Wear Pad Runways		JCB Waxoyl	
Boom Hoses		JCB Special Slide Lubricant	

†† **Note:** This is nominal machine capacity. The total hydraulic system capacity depends on the equipment being used. Fill with all rams closed. Watch level sight glass when filling.

† **Note:** This is a system capacity. Use the 'MIN' and 'MAX' marks on the dipstick when refilling the system.

Coolant Mixtures	%	Antifreeze	Starts to Freeze
	55	9.35 litres (2.04 gal)	-36° C (-33 °F)

Torque Settings

Use only where no torque setting is specified in the text. Values are for dry threads and may be within three per cent of the figures stated. For lubricated threads the values should be REDUCED by one third.

UNF Grade 'S' Bolts

Bolt Size		Hexagon (A/F)	Torque Settings		
in	(mm)	in	Nm	kgf m	lbf ft
1/4	(6.3)	7/16	14	1.4	10
5/16	(7.9)	1/2	28	2.8	20
3/8	(9.5)	9/16	49	5.0	36
7/16	(11.1)	5/8	78	8.0	58
1/2	(12.7)	3/4	117	12.0	87
9/16	(14.3)	13/16	170	17.3	125
5/8	(15.9)	15/16	238	24.3	175
3/4	(19.0)	1 1/8	407	41.5	300
7/8	(22.2)	1 5/16	650	66.3	480
1	(25.4)	1 1/2	970	99.0	715
1 1/4	(31.7)	1 7/8	1940	198.0	1430
1 1/2	(38.1)	2 1/4	3390	345.0	2500

Metric Grade 8.8 Bolts

Bolt Size		Hexagon (A/F)	Torque Settings		
	(mm)	mm	Nm	kgf m	lbf ft
M5	(5)	8	7	0.7	5
M6	(6)	10	12	1.2	9
M8	(8)	13	28	3.0	21
M10	(10)	17	56	5.7	42
M12	(12)	19	98	10	72
M16	(16)	24	244	25	180
M20	(20)	30	476	48	352
* M24	(24)	36	822	84	607
M30	(30)	46	1633	166	1205
M36	(36)	55	2854	291	2105

Rivet Nut Bolts/Screws

Bolt Size		Torque Settings (for steel rivet nuts)		
	(mm)	Nm	kgf m	lbf ft
M3	(3)	1.2	0.12	0.9
M4	(4)	3.0	0.3	2.0
M5	(5)	6.0	0.6	4.5
M6	(6)	10.0	1.0	7.5
M8	(8)	24.0	2.5	18.0
M10	(10)	48.0	4.9	35.5
M12	(12)	82.0	8.4	60.5

Note: All bolts used on JCB machines are high tensile and must not be replaced by bolts of a lesser tensile specification.

Identifying Your Machine

Identification Plate

Your machine has an identification plate **V** mounted as shown. The serial numbers of the machine and its major units are stamped on the plate.

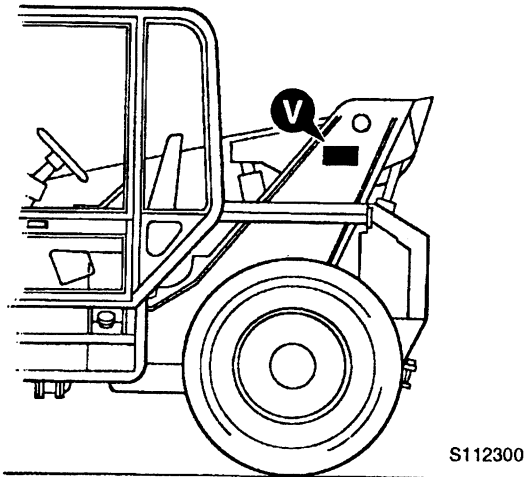

Explanation of Vehicle Identification Number (VIN)

JCB **SLP53012RE0561001** **JCB**

A B C D E

A	World Manufacturer Identification	SLP = JCB
B	Machine Model	53012 = 530-120
C	Year of Manufacture	S
	P = 1993	V = 1997
	R = 1994	W = 1998
	S = 1995	X = 1999
	T = 1996	Y = 2000
D	Manufacturing Location	E = England
E	Machine Serial Number	0561001

Machine Model Explanation

530 - 120
F G H

- F** 500 Series machine range
- G** 3.0 tonnes lift capacity
- H** 12.0 meters lift height

The serial number of each major unit is also stamped on the unit itself. If a major unit is replaced by a new one, the serial number on the identification plate will be wrong. Either stamp the new number of the unit on the identification plate, or simply stamp out the old number. This will prevent the wrong unit number being quoted when replacement parts are ordered.

The machine and engine serial numbers can help identify exactly the type of equipment you have.

Unit Identification

The engine serial number is stamped on label **W** which is fastened to the right side of the cylinder block, near the filter.

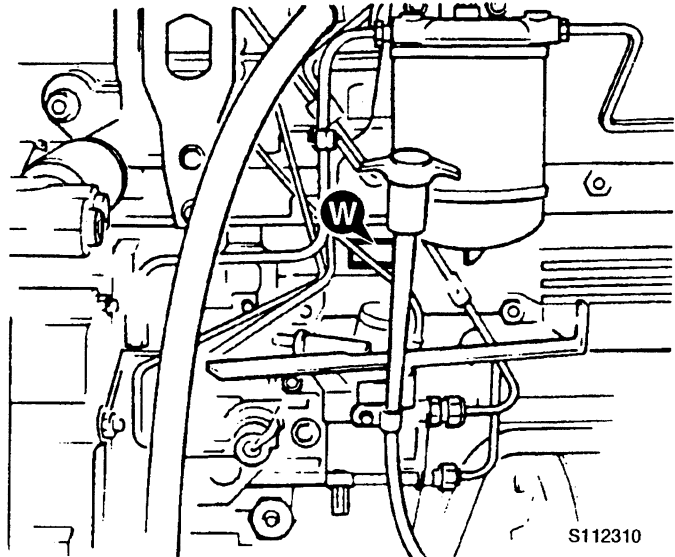

AA 50261 U 500405 P
A B C D E

- A** Engine Type
AA = 4 cylinder naturally aspirated
AB = 4 cylinder turbo
- B** Build Number
- C** Country of Origin
- D** Engine Sequence Number
- E** Year of Manufacture

The Syncro Shuttle serial number is stamped on label **Y** as shown.

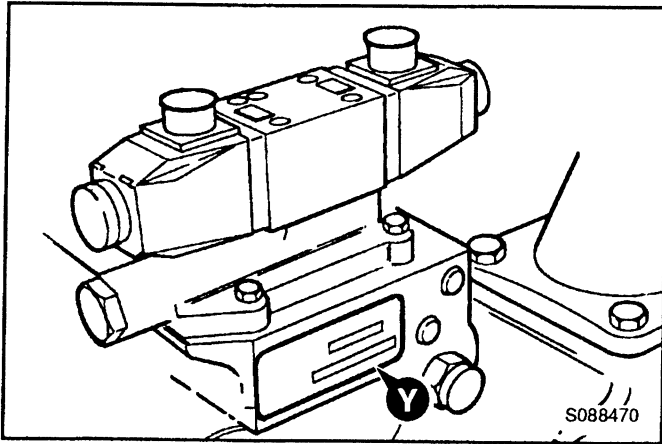

The rear axle serial number is stamped on plate **X** as shown.

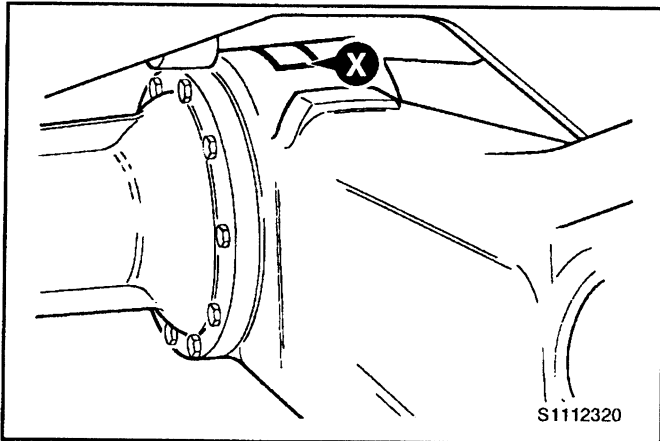

The front axle serial number is stamped on plate **Z** as shown.

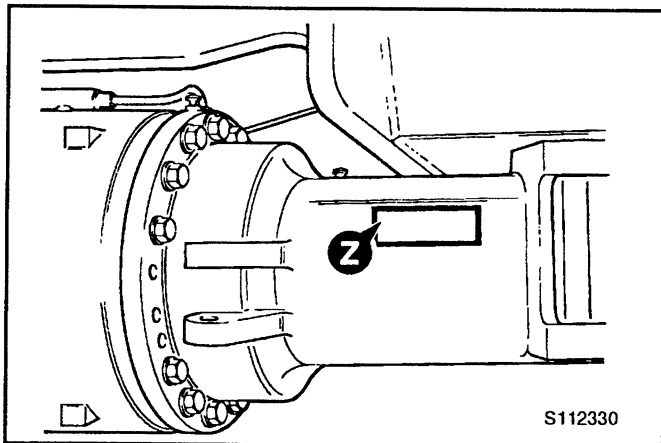

Pre-start Cold Checks Service Points and Fluid Levels	Operation	Daily	Weekly	Initial	Monthly	6 Monthly	Yearly	2 Yearly
		10 Hr	50 Hr	100 Hr	250 Hr	500 Hr	1000 Hr	2000 Hr

ENGINE

Engine Air Filter Pre-cleaner	Clean	•	•		•	•	•	•
Coolant Level and Condition	Check	•	•	•		•	•	•
* Fuel System For Leaks and Contamination	Check			•				
Oil Level and Condition	Check	•	•	•	•	•	•	•
Fuel Filter	Drain		•		•	•	•	•
Fuel Sedimenter	Drain and Clean		•	•	•	•	•	•
Air Cleaner Dust Valve	Clean			•	•	•	•	•
* Oil and Filter	Change			•		•	•	•
Fuel Lift Pump	Clean			•		•	•	•
Engine Mounting Bolts	Check			•		•	•	•
Fuel Filter	Change			•		•	•	•
Air Cleaner Outer Element	Change					•	•	•
Valve Clearance	Check							•
Air Cleaner Inner Element	Change							•
Fan Belt Tension/Condition	Check			•		•	•	•
* Engine Exhaust for Security	Check			•		•	•	•
* Air Inlet for Security	Check			•		•	•	•
Radiator	Clean					•	•	•
All hoses	Condition			•	•	•	•	•

TRANSMISSION AND AXLES

Transmission Oil Level	Check	•	•	•	•	•	•	•
Tyre Pressures and Condition (see Handbook)	Check	•	•	•	•	•	•	•
Tightness of Wheel Nuts	Check	•	•	•	•	•	•	•
Axle(s) Oil Level	Check			•	•	•	•	•
Axle(s) Oil	Change					•	•	•
Hub Oil Levels	Check			•	•	•	•	•
Hub Oil	Change					•	•	•
Drive Shafts and Universal Joints	Grease		•	•	•	•	•	•
Steer Axle Pivots and Linkages	Grease		•	•	•	•	•	•
Wheel Alignment (see Handbook)	Check	•	•	•	•	•	•	•
Wheel Bearings	Check and Adjust					•	•	•
King Pin and Bushes	Check and Adjust					•	•	•
Transmission Oil Filter	Change			•		•	•	•
Transmission Oil	Change						•	•
Transmission Strainer	Clean						•	•
Axle Breathers	Check Clear			•				
Axle Security	Check			•				
Transmission Mount Security	Check			•				
Steering Stops (if fitted)				•				

HYDRAULICS

Hydraulic Fluid Level	Check	•	•	•	•	•	•	•
System for Leaks	Check	•	•	•	•	•	•	
Oil Filter	Change			•	•	•	•	•
Oil (and clean suction strainers)	Sample/Change						•	

Pre-start Cold Checks Service Points and Fluid Levels		Operation	Daily 10 Hr	Weekly 50 Hr	Initial 100 Hr	Monthly 250 Hr	6 Monthly 500 Hr	Yearly 1000 Hr	2 Yearly 2000 Hr
BRAKES									
Fluid Level	Check		•	•	•	•	•	•	•
Parking Brake Cable	Lubricate				•	•	•	•	•
Brake System Fluid	Change								•
ELECTRICS									
Alternator Drive Belt Tension	Check			•			•	•	•
Battery Terminals for Condition and Tightness	Check				•	•	•	•	•
Wiring Harness for Chafing	Check				•	•			
Battery Electrolyte Level and Condition	Check				•		•	•	•
Starter Motor and Alternator	Check				•				•
Battery Charge Condition	Check				•				
BODY AND FRAMEWORK									
All Pivot Pins	Grease			•	•	•	•	•	•
Control Lever Linkages	Lubricate			•	•	•	•	•	•
All Hinges	Lubricate				•	•	•	•	•
* Wear Pad Runways	Waxoyl						•	•	•
Inner Boom Hoses	Grease						•	•	•
* Boom Extension Ram Pivot	Check and Grease							•	•
Boom Wear Pad (Machines from S/No. 561001)	Check					•	•	•	•
Inner Extension Ram Wear Pad (530-95/110)	Replace							•	•
* Wear Pad Condition	Check				•				
CAB									
Windscreen Washer Fluid Level	Fill		•	•	•	•	•	•	•
Seat Belt/Seat Security and Condition	Check		•	•	•	•	•	•	•
Fire Extinguisher	Check		•	•		•	•	•	•
Cab Heater Filter (if fitted)	Clean						•	•	•
Wing Mirrors Condition and Security	Check		•	•		•	•	•	•
ROPS/FOPS Structure	Check					•	•	•	•
ATTACHMENTS									
Carriage Lock Pins	Grease			•		•	•	•	•
Fork Pivot Pins	Grease						•	•	•
Optional Attachments (as required)	Grease								
Forks Fit and Check Security				•					

Buy Now



Our support email:

ebooklibonline@outlook.com