

WLS 422ZX

Service Manual - WLS 422ZX

[Section 1 - General Information](#)

[Section 2 - Care and Safety](#)

[Section 3 - Routine Maintenance](#)

[Section B - Body and Framework](#)

[Section C - Electrics](#)

[Section E - Hydraulics](#)

[Section F - Transmission](#)

[Section G - Brakes](#)

[Section H - Steering](#)

[Section K - Engine](#)



Publication No.
9813/3800-01



Copyright © 2004 JCB SERVICE. All rights reserved. No part of this publication may be reproduced, stored in a retrieval system, or transmitted in any form or by any other means, electronic, mechanical, photocopying or otherwise, without prior permission from JCB SERVICE.

General Information

Service Manual - WLS 422ZX

[Section 1 - General Information](#)

[Section 2 - Care and Safety](#)

[Section 3 - Routine Maintenance](#)

[Section B - Body and Framework](#)

[Section C - Electrics](#)

[Section E - Hydraulics](#)

[Section F - Transmission](#)

[Section G - Brakes](#)

[Section H - Steering](#)

[Section 1 - General Information](#)



Publication No.
9813/3800-01



Copyright © 2004 JCB SERVICE. All rights reserved. No part of this publication may be reproduced, stored in a retrieval system, or transmitted in any form or by any other means, electronic, mechanical, photocopying or otherwise, without prior permission from JCB SERVICE.



Section 1 - General Information

Contents	Page No.
Introduction	
About this Manual	1-1
Machine Model and Serial Number	1-1
Using the Service Manual	1-1
Left Side, Right Side	1-1
Cab/Canopy	1-1
Cross References	1-1
Machine Description	1-2
The JCB Wheeled Loader	1-2
Intended Use	1-2
Component Location	1-2
Identifying Your Machine	1-4
Machine Identification Plate	1-4
Standard Torque Settings	
Zinc Plated Fasteners and Dacromet Fasteners	1-7
Introduction	1-7
Bolts and Screws	1-7
Hydraulic Connections	1-11
'O' Ring Face Seal System	1-11
'Torque Stop' Hose System	1-14
JCB Standard Torque Settings	1-15
B.S.P. Port Connection (Colour Coded)	1-15
Hose Ends and Flanged Fittings (Colour Coded)	1-17
Service Tools	
Numerical List	1-21
Tool Detail Reference Section B - Body and Framework	1-22
Numerical List Section C - Electrics	1-26
Tool Detail Reference Section C - Electrics	1-27
Numerical List Section E - Hydraulics	1-28
Tool Detail Reference Section E- Hydraulics	1-31
Numerical List Section F - Transmission	1-34
Tool Detail Reference Section F - Transmission	1-35
Numerical List Section K - Engine	1-38
Tool Detail Reference Section K - Engine	1-39
Service Consumables	
Sealing and Retaining Compounds	1-41
Terms and Definitions	
.....	1-43
Hydraulic Schematic Colour Codes	1-43

Introduction

About this Manual

Machine Model and Serial Number

This manual provides information for 422ZX Wheel Loading Shovel Model:

- 422ZX from 2089665 to 2090665.

Using the Service Manual

T11-004

This publication is designed for the benefit of JCB Distributor Service Engineers who are receiving, or have received, training by JCB Technical Training Department.

These personnel should have a sound knowledge of workshop practice, safety procedures, and general techniques associated with the maintenance and repair of hydraulic earthmoving equipment.

The illustrations in this publication are for guidance only. Where the machines differ, the text and/or the illustration will specify.

General warnings in Section 2 are repeated throughout the manual, as well as specific warnings. Read all safety statements regularly, so you do not forget them.

Renewal of oil seals, gaskets, etc., and any component showing obvious signs of wear or damage is expected as a matter of course. It is expected that components will be cleaned and lubricated where appropriate, and that any opened hose or pipe connections will be blanked to prevent excessive loss of hydraulic fluid and ingress of dirt.

Where a torque setting is given as a single figure it may be varied by plus or minus 3%. Torque figures indicated are for dry threads, hence for lubricated threads may be reduced by one third.

The manufacturer's policy is one of continuous improvement. The right to change the specification of the machine without notice is reserved. No responsibility will be accepted for discrepancies which may occur between specifications of the machine and the descriptions contained in this publication.

Finally, please remember above all else safety must come first!

Left Side, Right Side

In this manual, 'left' **A** and 'right' **B** mean your left and right when you are seated correctly in the machine.

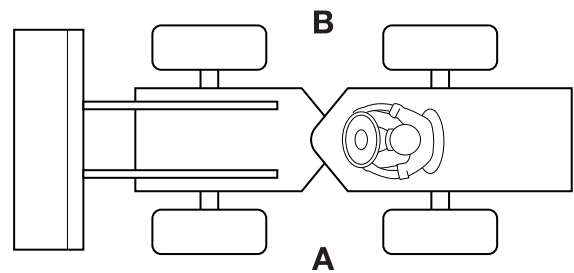

Fig 1.

T033800-1

Cab/Canopy

T1-003_2

This manual frequently makes references to the cab. For instance, 'do not operate the machine without a manual in the cab'. It should be noted that these statements also apply to canopy build machines.

Cross References

T1-004_2

In this publication, page cross references are made by presenting the subject title printed in bold, italic and underlined. It is preceded by the 'go to' symbol. The number of the page upon which the subject begins, is indicated within the brackets. For example: ⇒ **Cross References (1-1)**.

Machine Description

The JCB Wheeled Loader

P4-1002

Self-propelled wheeled machine with an integral front mounted shovel-supporting structure and linkage, which loads or excavates through forward motion of the machine, and lifts, transports and discharges material.

Intended Use

The machine is intended to be used under normal conditions for the applications described in this manual. If the machine is used for other purposes or in dangerous environments, for example in a flammable atmosphere or in areas with dust containing asbestos, special safety regulations must be followed and the machine must be equipped for use in these environments.

Component Location

- 1 Radiator
- 2 Battery isolator switch
- 3 Batteries
- 4 Water separator pre-filter
- 5 Beacon (option)
- 6 Rear work lights
- 7 Rain cap (air filter system) Pre-air cleaner
- 8 Exhaust stack
- 9 Engine cover
- 10 Rear grille
- 11 Bucket
- 12 Loader arm
- 13 ram
- 14 Front work lights
- 15 Tool box
- 16 Hydraulic oil level sight glass
- 17 Coolant filler cap - access point
- 18 Engine cover
- 19 Front Windshield Guard (optional)

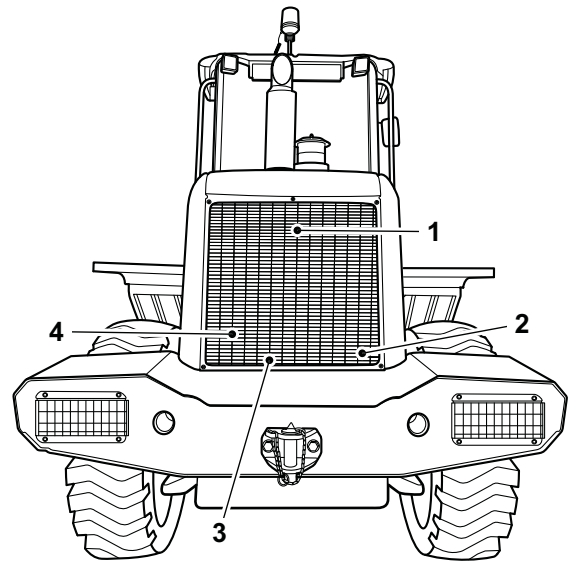

Fig 2.

T065830

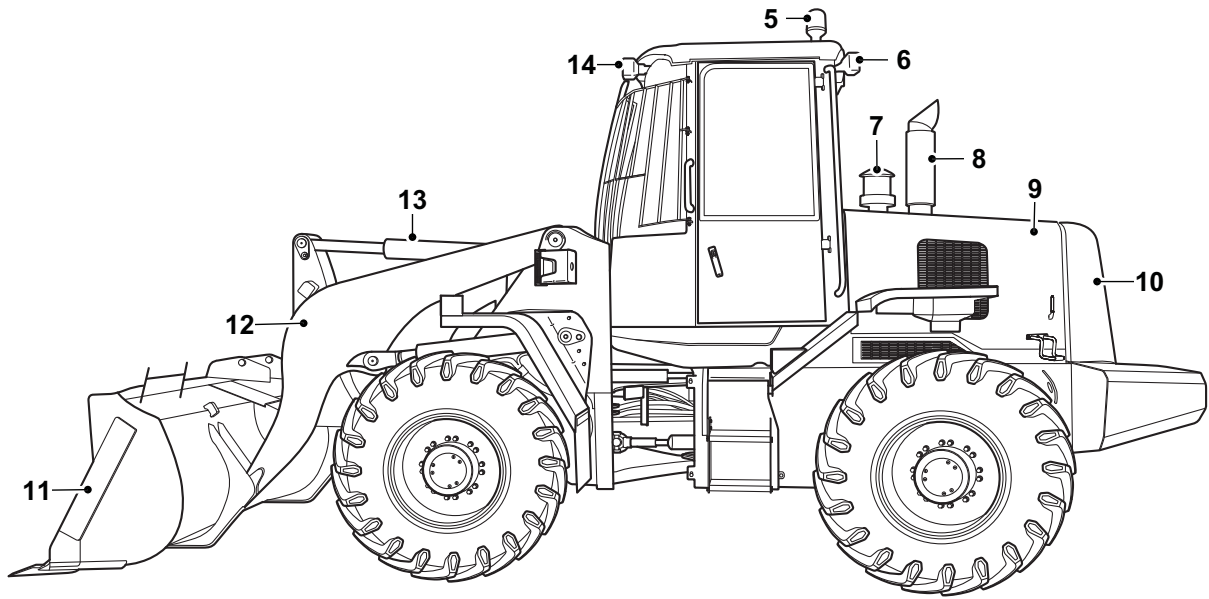

Fig 3.

T065720

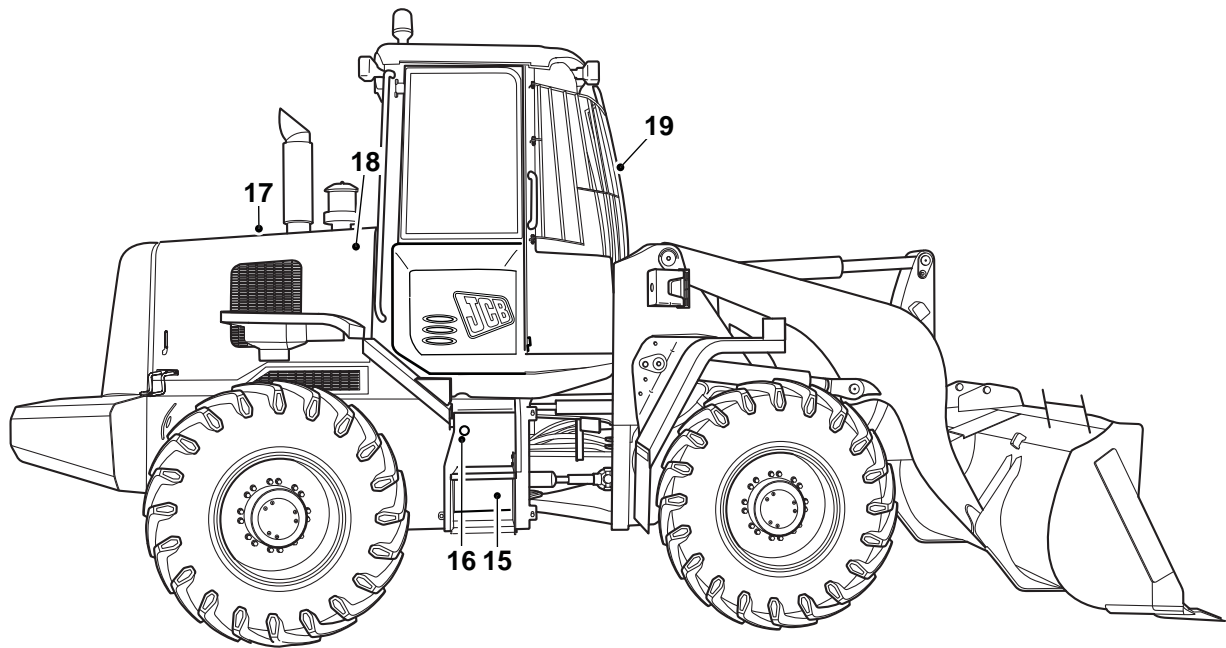

Fig 4.

D070900-02

Identifying Your Machine

Machine Identification Plate

Your machine has an identification. → Fig 5. (□ 1-4).

The machine and engine serial numbers can help identify exactly the type of equipment you have.

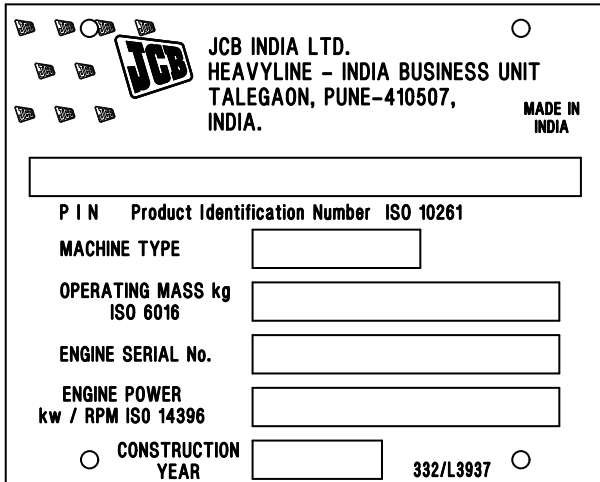

Fig 5.

D021850

4 Designation (1 Digit)

S = farmmaster

O = None Farmmaster

I = India

B = Brazil

5 Check Letter (1 Digit)

The Check Letter is used to verify the authenticity of the machines Product Identification Number (PIN).

6 Machine Serial Number (8 Digits)

Each machine has a unique serial number

Typical Product Identification Number (PIN)

1	2	3	4	5	6
JCB	422	Z	I	D	2089665

1 World Manufacturer Identification (3 Digits)

2 Machine Number (3 Digits)

3 loader End Type (1 Digit)

O = HT Loader End

Z = ZX Loader End

Engine Data Plate

Each JCB Engine has an emissions legislation table.

⇒ [Fig 6.](#) (□ 1-5).

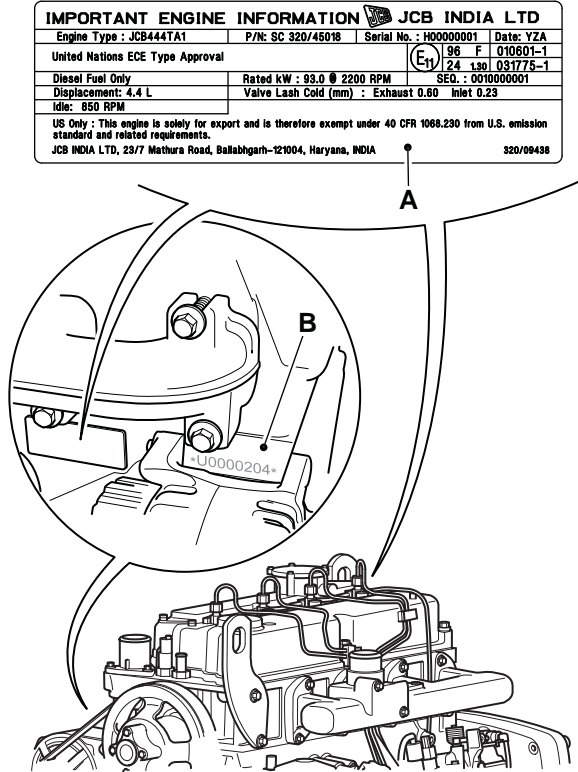

Fig 6.

D070720

Standard Torque Settings

Zinc Plated Fasteners and Dacromet Fasteners

T11-002

Introduction

Some external fasteners on JCB machines are manufactured using an improved type of corrosion resistant finish. This type of finish is called Dacromet and replaces the original Zinc and Yellow Plating used on earlier machines.

The two types of fasteners can be readily identified by colour and part number suffix. ⇒ [Table 1. Fastener Types](#) (1-7).

Table 1. Fastener Types

Fastener Type	Colour	Part No. Suffix
Zinc and Yellow	Golden finish	'Z' (e.g. 1315/3712Z)
Dacromet	Mottled silver finish	'D' (e.g. 1315/3712D)

Note: As the Dacromet fasteners have a lower torque setting than the Zinc and Yellow fasteners, the torque figures used must be relevant to the type of fastener.

Note: A Dacromet bolt should not be used in conjunction with a Zinc or Yellow plated nut, as this could change the torque characteristics of the torque setting further. For the same reason, a Dacromet nut should not be used with a Zinc or Yellow plated bolt.

Note: All bolts used on JCB machines are high tensile and must not be replaced by bolts of a lesser tensile specification.

Note: Dacromet bolts, due to their high corrosion resistance are used in areas where rust could occur. Dacromet bolts are only used for external applications. They are not used in applications such as gearbox or engine joint seams or internal applications.

Bolts and Screws

Use the following torque setting tables only where no torque setting is specified in the text.

Note: Dacromet fasteners are lubricated as part of the plating process, do not lubricate.

Torque settings are given for the following conditions:

Condition 1

- Un-lubricated fasteners
- Zinc fasteners
- Yellow plated fasteners

Condition 2

- Zinc flake (Dacromet) fasteners
- Lubricated zinc and yellow plated fasteners
- Where there is a natural lubrication. For example, cast iron components

Verbus Ripp Bolts

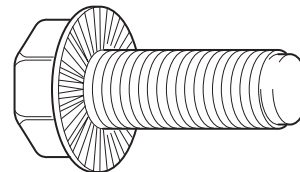

Fig 1.

Torque settings for these bolts are determined by the application. Refer to the relevant procedure for the required settings.



Section 1 - General Information Standard Torque Settings

Zinc Plated Fasteners and Dacromet Fasteners

Table 2. Torque Settings - UNF Grade 'S' Fasteners

Bolt Size		Hexagon (A/F)	Condition 1			Condition 2		
in.	mm	in.	Nm	kgf m	lbf ft	Nm	kgf m	lbf ft
1/4	6.3	7/16	11.2	1.1	8.3	10.0	1.0	7.4
5/16	7.9	1/2	22.3	2.3	16.4	20.0	2.0	14.7
3/8	9.5	9/16	40.0	4.1	29.5	36.0	3.7	26.5
7/16	11.1	5/8	64.0	6.5	47.2	57.0	5.8	42.0
1/2	12.7	3/4	98.0	10.0	72.3	88.0	9.0	64.9
9/16	14.3	13/16	140.0	14.3	103.2	126.0	12.8	92.9
5/8	15.9	15/16	196.0	20.0	144.6	177.0	18.0	130.5
3/4	19.0	1 1/8	343.0	35.0	253.0	309.0	31.5	227.9
7/8	22.2	1 15/16	547.0	55.8	403.4	492.0	50.2	362.9
1	25.4	1 1/2	814.0	83.0	600.4	732.0	74.6	539.9
1 1/8	31.7	1 7/8	1181.0	120.4	871.1	1063.0	108.4	784.0
1 1/4	38.1	2 1/4	1646.0	167.8	1214.0	1481.0	151.0	1092.3

Table 3. Torque Settings - Metric Grade 8.8 Fasteners

Bolt Size		Hexagon (A/F)	Condition 1			Condition 2		
ISO Metric Thread	mm	mm	Nm	kgf m	lbf ft	Nm	kgf m	lbf ft
M5	5	8	5.8	0.6	4.3	5.2	0.5	3.8
M6	6	10	9.9	1.0	7.3	9.0	0.9	6.6
M8	8	13	24.0	2.4	17.7	22.0	2.2	16.2
M10	10	17	47.0	4.8	34.7	43.0	4.4	31.7
M12	12	19	83.0	8.5	61.2	74.0	7.5	54.6
M16	16	24	205.0	20.9	151.2	184.0	18.8	135.7
M20	20	30	400.0	40.8	295.0	360.0	36.7	265.5
M24	24	36	690.0	70.4	508.9	621.0	63.3	458.0
M30	30	46	1372.0	139.9	1011.9	1235.0	125.9	910.9
M36	36	55	2399.0	244.6	1769.4	2159.0	220.0	1592.4



Section 1 - General Information Standard Torque Settings

Zinc Plated Fasteners and Dacromet Fasteners

Table 4. Metric Grade 10.9 Fasteners

Bolt Size		Hexagon (A/F)	Condition 1			Condition 2		
ISO Metric Thread	mm	mm	Nm	kgf m	lbf ft	Nm	kgf m	lbf ft
M5	5	8	8.1	0.8	6.0	7.3	0.7	5.4
M6	6	10	13.9	1.4	10.2	12.5	1.3	9.2
M8	8	13	34.0	3.5	25.0	30.0	3.0	22.1
M10	10	17	67.0	6.8	49.4	60.0	6.1	44.2
M12	12	19	116.0	11.8	85.5	104.0	10.6	76.7
M16	16	24	288.0	29.4	212.4	259.0	26.4	191.0
M20	20	30	562.0	57.3	414.5	506.0	51.6	373.2
M24	24	36	971.0	99.0	716.9	874.0	89.1	644.6
M30	30	46	1930.0	196.8	1423.5	1737.0	177.1	1281.1
M36	36	55	3374.0	344.0	2488.5	3036.0	309.6	2239.2

Table 5. Metric Grade 12.9 Fasteners

Bolt Size		Hexagon (A/F)	Condition 1			Condition 2		
ISO Metric Thread	mm	mm	Nm	kgf m	lbf ft	Nm	kgf m	lbf ft
M5	5	8	9.8	1.0	7.2	8.8	0.9	6.5
M6	6	10	16.6	1.7	12.2	15.0	1.5	11.1
M8	8	13	40.0	4.1	29.5	36.0	3.7	26.5
M10	10	17	80.0	8.1	59.0	72.0	7.3	53.1
M12	12	19	139.0	14.2	102.5	125.0	12.7	92.2
M16	16	24	345.0	35.2	254.4	311.0	31.7	229.4
M20	20	30	674.0	68.7	497.1	607.0	61.9	447.7
M24	24	36	1165.0	118.8	859.2	1048.0	106.9	773.0
M30	30	46	2316.0	236.2	1708.2	2084.0	212.5	1537.1
M36	36	55	4049.0	412.9	2986.4	3644.0	371.6	2687.7



Section 1 - General Information Standard Torque Settings

Zinc Plated Fasteners and Dacromet Fasteners

Table 6. Torque Settings - Rivet Nut Bolts/Screws

Bolt Size		Nm	kgf m	lbf ft
ISO Metric Thread	mm			
M3	3	1.2	0.1	0.9
M4	4	3.0	0.3	2.0
M5	5	6.0	0.6	4.5
M6	6	10.0	1.0	7.5
M8	8	24.0	2.5	18.0
M10	10	48.0	4.9	35.5
M12	12	82.0	8.4	60.5

Table 7. Torque Settings - Internal Hexagon Headed Cap Screws (Zinc)

Bolt Size	Nm	kgf m	lbf ft
ISO Metric Thread			
M3	2.0	0.2	1.5
M4	6.0	0.6	4.5
M5	11.0	1.1	8.0
M6	19.0	1.9	14.0
M8	46.0	4.7	34.0
M10	91.0	9.3	67.0
M12	159.0	16.2	117.0
M16	395.0	40.0	292.0
M18	550.0	56.0	406.0
M20	770.0	79.0	568.0
M24	1332.0	136.0	983.0

Hydraulic Connections

T11-003

'O' Ring Face Seal System

Adaptors Screwed into Valve Blocks

Adaptor screwed into valve blocks, seal onto an 'O' ring which is compressed into a 45° seat machined into the face of the tapped port.

Table 8. Torque Settings - BSP Adaptors

BSP Adaptor Size	Hexagon (A/F)	Nm	kgf m	lbf ft
	in.			
1/4	19.0	18.0	1.8	13.0
3/8	22.0	31.0	3.2	23.0
1/2	27.0	49.0	5.0	36.0
5/8	30.0	60.0	6.1	44.0
3/4	32.0	81.0	8.2	60.0
1	38.0	129.0	13.1	95.0
1 1/4	50.0	206.0	21.0	152.0

Table 9. Torque Settings - SAE Connections

SAE Tube Size	SAE Port Thread Size	Hexagon (A/F)	Nm	kgf m	lbf ft
		mm			
4	7/16 - 20	15.9	20.0 - 28.0	2.0 - 2.8	16.5 - 18.5
6	9/16 - 18	19.1	46.0 - 54.0	4.7 - 5.5	34.0 - 40.0
8	3/4 - 16	22.2	95.0 - 105.0	9.7 - 10.7	69.0 - 77.0
10	7/8 - 14	27.0	130.0 - 140.0	13.2 - 14.3	96.0 - 104.0
12	1 1/16 - 12	31.8	190.0 - 210.0	19.4 - 21.4	141.0 - 155.0
16	1 5/16 - 12	38.1	290.0 - 310.0	29.6 - 31.6	216.0 - 230.0
20	1 5/8	47.6	280.0 - 380.0	28.5 - 38.7	210.0 - 280.0

Hoses Screwed into Adaptors

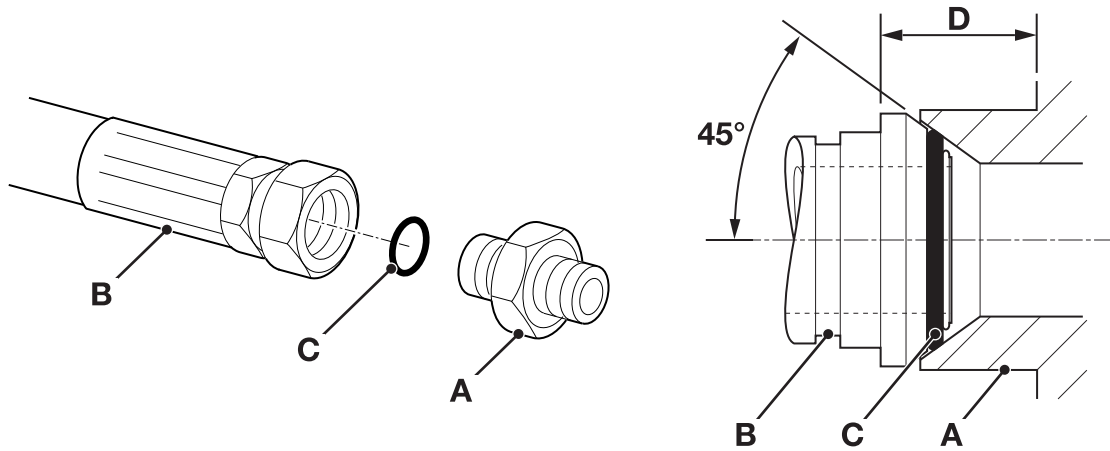

Fig 2.

Hoses **2-B** screwed into adaptors **2-A** seal onto an 'O' ring **2-C** which is compressed into a 45° seat machined into the face of the adaptor port.

Note: Dimension **2-D** will vary depending upon the torque applied.

Table 10. BSP Hose - Torque Settings

BSP Hose Size	Hexagon (A/F)	Nm	kgf m	lbf ft
	in.			
1/8	14.0	14.0 - 16.00	1.4 - 1.6	10.3 - 11.8
1/4	19.0	24.0 - 27.0	2.4 - 2.7	17.7 - 19.9
3/8	22.0	33.0 - 40.0	3.4 - 4.1	24.3 - 29.5
1/2	27.0	44.0 - 50.0	4.5 - 5.1	32.4 - 36.9
5/8	30.0	58.0 - 65.0	5.9 - 6.6	42.8 - 47.9
3/4	32.0	84.0 - 92.0	8.6 - 9.4	61.9 - 67.8
1	38.0	115.0 - 126.0	11.7 - 12.8	84.8 - 92.9
1 1/4	50.0	189.0 - 200.0	19.3 - 20.4	139.4 - 147.5
1 1/2	55.0	244.0 - 260.0	24.9 - 26.5	180.0 - 191.8

Buy Now



Our support email:

ebooklibonline@outlook.com