



SERVICE MANUAL

VM117, VM137

EN - 9813/4900 - ISSUE 1 - 09/2015

This manual contains original instructions, verified by the manufacturer (or their authorized representative).

Copyright 2015 © JCB SERVICE
All rights reserved. No part of this publication may be reproduced, stored in a retrieval system, or transmitted in any form or by any other means, electronic, mechanical, photocopying or otherwise, without prior permission from JCB SERVICE.

www.jcb.com

Foreword

The Operator's Manual

 You and others can be killed or seriously injured if you operate or maintain the machine without first studying the Operator's Manual. You must understand and follow the instructions in the Operator's Manual. If you do not understand anything, ask your employer or JCB dealer to explain it.

Do not operate the machine without an Operator's Manual, or if there is anything on the machine you do not understand.

Treat the Operator's Manual as part of the machine. Keep it clean and in good condition. Replace the Operator's Manual immediately if it is lost, damaged or becomes unreadable.

Contents

01 - Machine

06 - Body and Framework

09 - Operator Station

15 - Engine

18 - Fuel and Exhaust System

21 - Cooling System

24 - Brakes

25 - Steering System

27 - Driveline

30 - Hydraulic System

33 - Electrical System

72 - Fasteners and Fixings

75 - Consumable Products

78 - After Sales

Engine Oil Pressure

Use the following procedures to measure the engine oil pressure. Refer to Oil Sump (PIL 15-45) for a full explanation of the lubricating oil circuit. Several factors can influence the engine oil pressure, the following conditions are assumed:

- The correct engine oil has been used, refer to Consumable Products, Oil (PIL 75-03).
 - The engine oil level is correct, refer to Oil Filter, Check Level (PIL 15-21).
1. Make sure that the engine is safe to work on. If the engine has been running, let it cool before you start the service work.
 2. Get access to the engine.
 3. Disconnect the electrical connector to the oil pressure switch, and remove the switch from the oil cooler housing.
 4. Install a suitable test gauge into the vacant pressure switch port (M10 x 1.5mm thread). Make sure that the gauge has a sealing washer as shown.

Special Tool: Pressure Gauge (0-40 Bar) (Qty.: 1)

Figure 38.

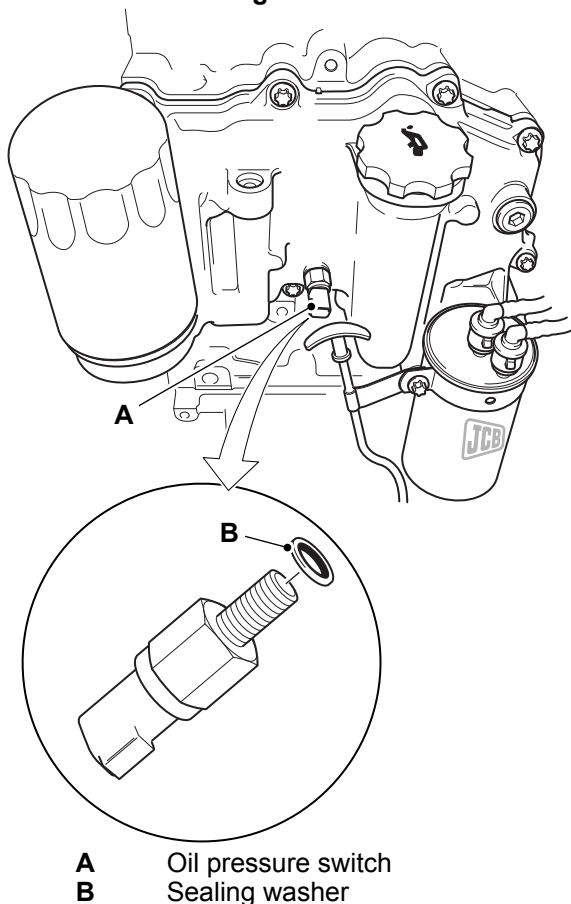

5. Start the engine, increase the engine revs to the rated speed. Record the pressure gauge reading, refer to Technical Data (PIL 15-00), for the recommended circuit pressure.
6. Remove the pressure gauge and install the pressure switch.

High Lubrication Oil Pressure

High oil pressure will be evident when starting in cold conditions. Typically the pressure will be 1–2bar (14.5–29.0psi) and higher in cold operation, the pressure should drop when the engine reaches normal operating temperature.

If the pressure remains high when operating temperature is achieved, check the oil level, if this is correct, suspect the oil pump relief valve is at fault.

Low Lubrication Oil Pressure

Several factors can be the cause of low lubricating oil pressure:

- Low oil level - typically evident as a loss of pressure when operating on uneven ground or on a gradient.
- Blocked oil filter - a blocked filter will show as a gradual loss of pressure.
- Blocked suction strainer (pick-up pipe) - typically evident as low pressure on start up, if the blockage frees itself in the sump, the pressure will pick up to normal.
- Coolant in the oil - coolant in the lubricating oil will show as a milky discolouration of the oil and an increase in oil level. Check for damaged core plugs, lubricating oil cooler, cylinder head and/or gasket.
- Fuel in the oil - fuel in the oil will result in thin black lubricating oil, the oil will also have a diesel fuel smell. Check the fuel injection pump (FIP) shaft seal refer to (PIL 18-18), piston ring wear, lift pump diaphragm damage or injector leakage if fuel is evident in the oil.

Remove and Install

Special Tools

Description	Part No.	Qty.
Lifting Bracket Front	320/09062	1
Lifting Bracket Rear	320/09063	1
Engine Lifting Spreader Bar	892/01382	1

Lifting Equipment

You can be injured if you use incorrect or faulty lifting equipment. You must identify the weight of the item to be lifted then choose lifting equipment that is strong enough and suitable for the job. Make sure that lifting equipment is in good condition and complies with all local regulations.

The lifting equipment used must be an approved type and capable of lifting the engine safely. The

recommended lifting equipment is shown. Use a spreader bar when lifting the engine. Never attempt to manually lift heavy components on your own. Always use lifting equipment, or obtain the help of an assistant. Inspect the lifting brackets for signs of damage. The brackets must be correctly torqued to the crankcase. Make sure the lifting equipment does not damage any of the engine dressing and the rocker cover.

Component Identification

The following component identification is for a typical engine installation. There will be some component differences depending on the machine variant. Before attempting to remove the engine ensure that all the necessary components have either been removed, or safely disconnected from the engine.

Figure 39.

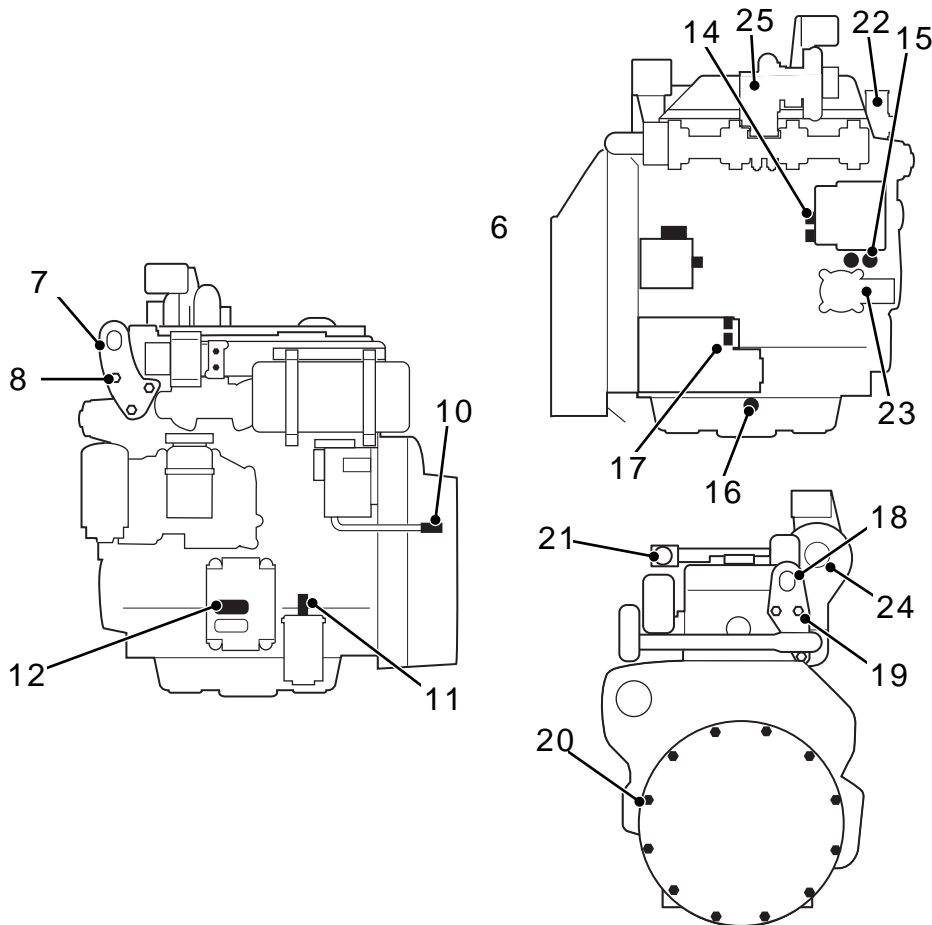

- 6 Engine mounting bolts
- 7 Lifting bracket- front
- 8 Lifting bracket fixing bolts
- 10 Fuel line connector- return to tank line

- 11 Fuel line connector at fuel filter- feed line from fuel pump

12	Electrical connector- engine ECM (Engine Control Module) machine side connector (grey)	19	Lifting bracket fixing bolts
14	Electrical connections- alternator	20	Fixing bolts- gearbox to engine
15	Hose connection- cab heater	21	Electrical connector- engine harness
16	Electrical sensor- engine oil level	22	Top hose
17	Electrical connections- starter motor	23	Bottom hose
18	Lifting bracket- rear	24	Air inlet hose
		25	Exhaust pipe

Before Removal

1. Make sure that the engine is safe to work on. If the engine has been running, let it cool before you start the service work.
2. Position the machine on firm level ground. Make the machine safe, refer to (PIL 01-03).
3. Get access to the engine.

Remove

1. Disconnect and remove the battery, refer to (PIL 33-03).
2. Drain the engine oil, refer to (PIL 15-21).
3. Drain the engine coolant, remove the cooling pack refer to (PIL 21-03).
4. Discharge the hydraulic pressure, refer to (PIL 30-00).
5. Drain the hydraulic tank. Disconnect and plug the hydraulic suction and delivery lines at the transmission pump and gear pump. Label the hoses to ensure correct reassembly. refer to (PIL 30-00).
6. Disconnect and plug the hydraulic cooler hoses. Label the hoses to ensure correct reassembly
7. Disconnect the exhaust system.
8. Label the cab heater hoses at the engine block connectors. Release the hose clips and remove the hoses.
9. Disconnect the wiring connections from the starter motor, refer to (PIL 15-75).
10. Disconnect the wiring connections from the alternator, refer to (PIL 15-72).
11. Disconnect the wiring connections from the engine sensors and actuators, refer to (PIL 15-84).
12. Disconnect the electrical connector at the oil level sensor (if installed).
13. Disconnect the fuel supply line at the fuel lift pump and the spill line at the fuel injection pump. Cap all hoses and ports to prevent ingress of dirt.
14. Disconnect the electrical harness at the engine harness.
15. Uncouple the electrical harness at the ECM machine side connector. Important: Do not touch the connector pins on the ECM or harness connectors. Cover the connectors to prevent contamination.
16. Ensure that all relevant harnesses and hoses are unclipped from the engine and tied out of the way.
17. Disconnect and plug the hoses at the hydraulic pump.
18. Disconnect the wiring to the hydraulic pump.
19. Remove the gearbox to engine retaining bolts, pull the transmission and converter clear of the engine, make sure that the converter stays mounted on the gearbox shaft.
20. Attach slings to the engine lifting eyes.
 - Special Tool: Lifting Bracket Front (Qty.: 1)
 - Special Tool: Lifting Bracket Rear (Qty.: 1)
 - Special Tool: Engine Lifting Spreader Bar (Qty.: 1)
21. Take the weight of the engine on the hoist and remove the engine mounting bolts.
22. Withdraw the engine in a level attitude until the hydraulic pump is clear of the chassis. Raise the engine to lift it clear of the machine.
23. Lower the engine into a suitable stand that is capable of supporting the weight of the engine.

Figure 40.

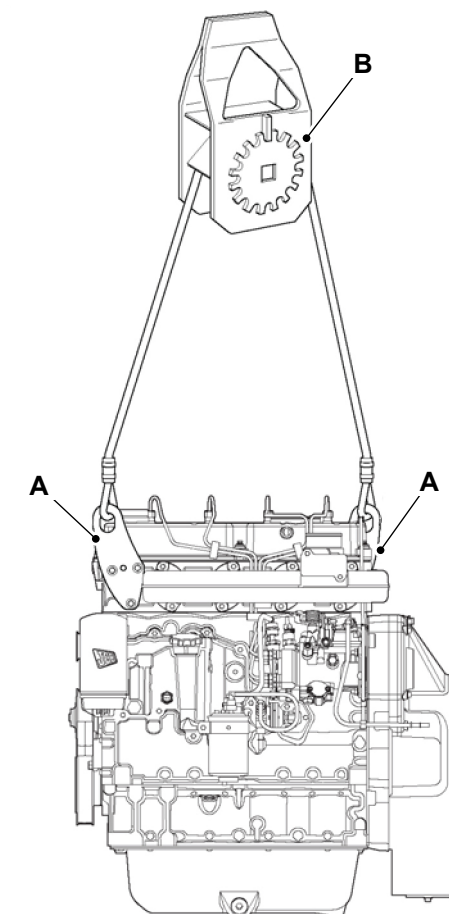

A Lifting bracket mounting bolts

B Lifting equipment**Install**

1. Replacement is a reversal of the removal procedure. Note the following:
2. Important: It is vitally important that the torque converter is installed at the gearbox and engine flywheel correctly. Failure to locate the converter correctly will result in damage to the gearbox oil pump on engine start up.
3. Fill the cooling system with the correct mix of coolant fluid.
4. Fill and Check the hydraulic fluid level.
5. Fill and Check the engine oil levels.
6. On completion, check hydraulic and cooling system for leakage and levels.
7. Check the function of the drive and loader services.

Table 29. Torque Values

Item	Nm
A	47

Store and Recommission

Engines should be stored in the original shipping packaging. Damaged or disturbed packaging should be made weatherproof immediately.

If an engine is shipped with oil, it should be stored in the correct (upright) position.

If an engine is shipped dry of oil, after 6 months it should be filled with oil to the correct level and re-inhibited, refer to hot test description.

All floor stock engines should be stored under cover in dry conditions and not subjected to extreme variations in temperature or humidity.

If an engine is to be placed into storage, all external signs of surface coating damage or corrosion should be cleaned and re-coated. Electrical connectors and components should be coated with a protective spray.

Capping Engine Openings

All openings on the engine must be suitably capped to prevent ingress of water and contamination by foreign particles.

12 Month Revalidation Procedure

1. Pre-inspection:
 - 1.1. Inspect packaging for signs of damage.
 - 1.2. Inspect the caps for signs of damage.
 - 1.3. Inspect openings for signs of water or dirt ingress.
 - 1.4. Inspect the engine for signs of external corrosion.
 - 1.5. Inspect the engine for signs of fluid leaks.
2. From storage:
 - 2.1. Remove the air intake caps.
 - 2.2. Make sure the engine oil level is correct.
 - 2.3. Using a suitable power supply at the correct voltage, crank the engine over.
 - 2.4. During cranking, check that the oil pressure switch opens using a multimeter. The switch is closed when there is no or low oil pressure and opens when oil pressure reaches a set point. After three separate 20 second cranking periods, If the oil pressure switch does not open (indicating no, or low oil pressure), contact your JCB engine dealer.
 - 2.5. Recap all engine openings.

- 2.6. Coat any exposed bare metal with a suitable product.
- 2.7. Electrical connectors and components should be coated with a protective spray if exposed.
- 2.8. Cover in weatherproof packaging.
- 2.9. Place in storage, under cover on level ground or shelving.
- 2.10. Record details of work as required.
- 2.11. Do not expose to extremes of temperature or humidity.

Notice: Do not operate the starter motor for more than 20s at one time. Let the starter motor cool for at least 2min.

Table 30. Oil Pressure Switch Set Points

Oil pressure switch closed	>0.6bar (8.7psi)
Oil pressure switch open	<0.6bar (8.7psi)

OEM Commissioning Check on Engine Installation After More Than 12 Months

1. Flush the coolant system with proprietary flushing solution.
2. Refill the coolant system with 50/50 mix of long term antifreeze mixture.
3. Hot test engine according to the hot test profile. Refer to Table 31.
4. Drain engine oil and replace engine oil filter.
5. Refill with the correct oil and inhibit the cooling system using the correct product.
6. Record details of work as required.

Hot Test Description

▲ WARNING When using cleaning agents, solvents or other chemicals, you must adhere to the manufacturer's instructions and safety precautions.

All engines despatched from JCB will have been subjected to a hot test (checking items such as oil pressure, engines speeds, torque values etc.) and therefore the interior surfaces will have been coated with engine oil.

All coolant galleries are coated with CRODAFLUID PA75 corrosion inhibitor.

Stored engines will require re-inhibiting every 12 months, this will include hot testing the engine using a dynamometer. The hot test profile is:

Table 31. Hot Test Profile

Stage	Mode	Speed (rpm)	Torque (Nm)	Time (secs)
1	Speed/ Torque	830	0	50
2	Speed/ Torque	1300	50	60
3	Speed/ Torque	2500	0	60
4	Speed/ Torque	1300	0	25
5	Speed/ Torque	800	0	35

00 - General

Introduction 15-37
Technical Data 15-38

Introduction

The crankcase is the housing for the crankshaft. The enclosure forms the largest cavity in the engine and is located below the cylinders. It is integral with the cylinder bank and forms an engine block. It has an opening in the bottom to which an oil sump is attached with a gasket and bolted joint.

The crankcase protects the crankshaft and connecting rods from foreign objects it also keeps the engine oil contained and allows the oil to be pressurised and also provide the rigid structure with which to join the engine to the transmission.

Figure 41.

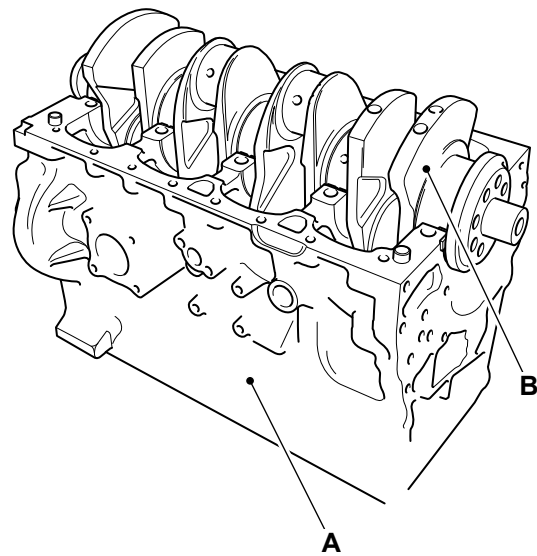

- A** Crankcase
- B** Crankshaft

Technical Data

Table 32. Crankcase and Bedplate Data

	4.4L	4.8L
Cylinder bore ⁽¹⁾	103–103.02mm	106–106.02mm
Main bearing bolts torque ⁽²⁾		
First stage	50N·m	50N·m
Second stage	115N·m	115N·m
Final stage	Turn a further 180°	Turn a further 180°
Surface finish for cylinder head joint ⁽³⁾	Rz < 15m, Rmax < 20	Rz < 15m, Rmax < 20
Diameter of first oversize bore	103.5–103.52mm	106.5–106.52mm
Diameter of second oversize bore	104–104.02mm	
Main bearing bore (without bearings)		
Numbers 1 to 4	92–92.02mm	92–92.02mm
Number 5	105–105.02mm	105–105.02mm
Main bearing bore (with bearings)		
Numbers 1 to 4	88.047–88.09mm	88.047–88.09mm
Number 5	100.047–100.09mm	100.047–100.09mm
Camshaft bore		
Numbers 1 to 4	60.04–60.07mm	60.04–60.07mm
Number 5 (bush)	60.29–60.32mm	60.29–60.32mm
Permissible wave profile	wt < 10m (2.5 distance)	wt < 10m (2.5 distance)

(1) Nominal diameter to be measured 63mm below the cylinder head face.

(2) Torque information **MUST** be used in conjunction with the recommended procedures contained in this manual. Failure to use the appropriate and correct removal, replacement, dismantle and assembly procedures may result in an engine failure in service. Refer also to the procedures for the correct bolt tightening sequence.

(3) The crankcase to cylinder head surface may be skimmed and restored using the oversize gaskets (0.25mm and 0.5mm).

Technical Data

Table 33. Cylinder Head Data

Cylinder head distortion (maximum permissible) ⁽¹⁾	
- End to end	0.05mm
- Side to side	0.03mm
Valve recess depth	
- Inlet	0.85mm
- Exhaust	0.85mm
Valve seat angle	
- Inlet	120(inclusive)
- Exhaust	90(inclusive)
Cylinder head bolts torque ⁽²⁾	
- First stage	40
- Second stage	75
- Third stage	Repeat75
- Fourth stage	Torque angle + 90
- Final stage	Torque angle + 180
Surface finish for cylinder head joint	Rz < 15 Rmax < 20
Permissible wave profile	wt < 10m 2.5 distance

(1) The block to cylinder head surface may be skimmed and restored using the oversize gaskets (0.25mm and 0.5mm).

(2) Torque information **MUST** be used in conjunction with the recommended procedures contained in this manual. Failure to use the appropriate and correct remove, install, disassemble and assemble procedure may result in an engine failure in service. Refer also to the procedures for the correct bolt tightening sequence.

Remove and Install

Special Tools

Description	Part No.	Qty.
Torque Wrench (10-100Nm)	993/70111	1

Consumables

Description	Part No.	Size
Cleaner/Degreaser - General purpose solvent based parts cleaner	4104/1557	0.4L

Before Removal

1. This procedure requires service parts. Make sure you have obtained the correct parts before you start, refer to Parts Catalogue.
2. Make sure that the engine is safe to work on. If the engine has been running, let it cool before you start the service work.
3. Get access to the engine.
4. Remove the thermostat, refer to (PIL 21-12).
5. Remove the fuel pipes, refer to (PIL 18-96).
6. Remove the rocker cover, refer to (PIL 15-42).
7. Remove the fuel injectors, refer to (PIL 18-18).
8. Remove the rocker assembly, refer to (PIL 15-42).
9. Remove the exhaust manifold, refer to (PIL 18-24).
10. Remove the inlet manifold, refer to (PIL 18-24).

Figure 42.

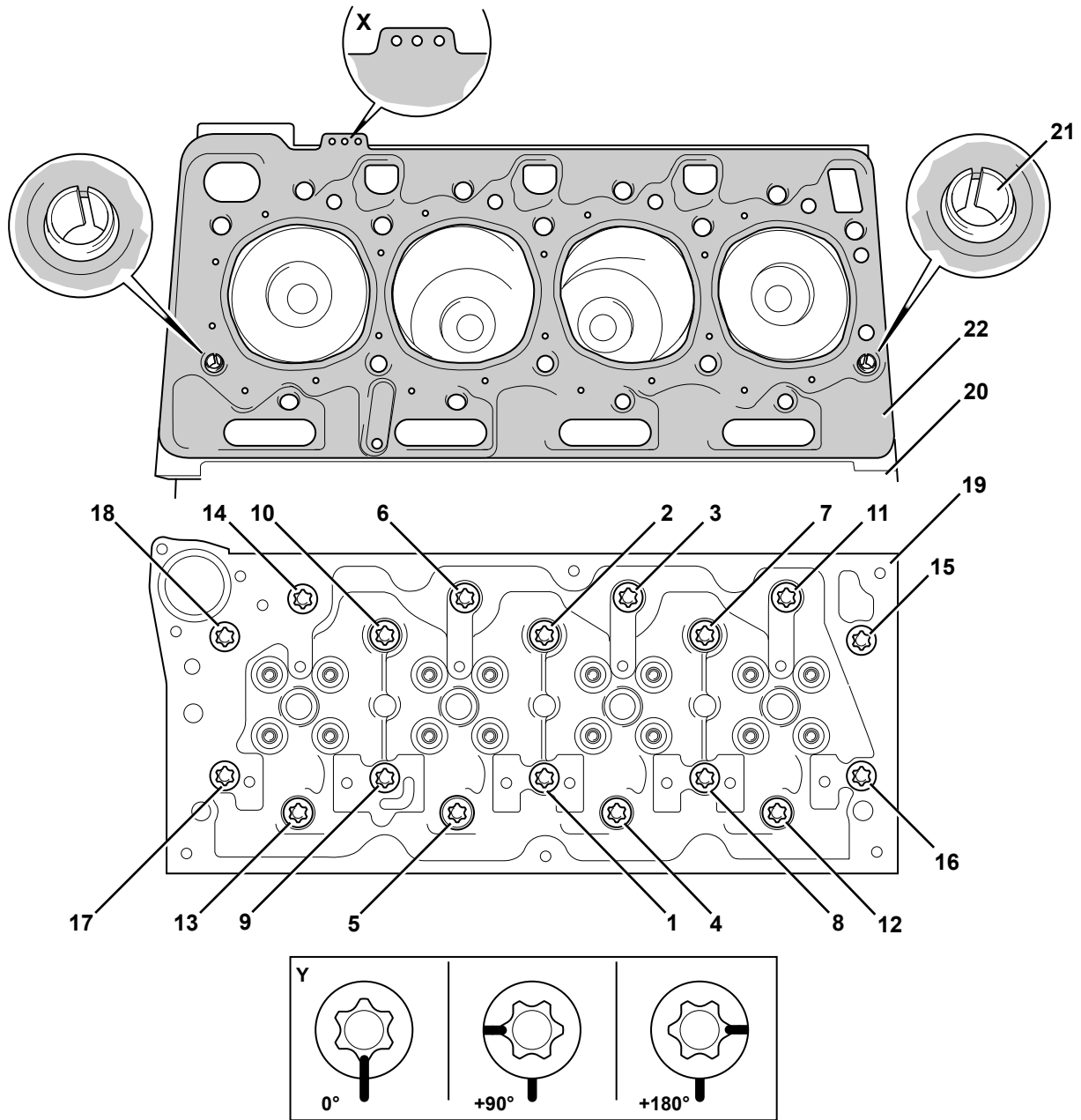

- 1-18** Cylinder head fixing bolts (x18)
- 19** Cylinder head
- 20** Crankcase

- 21** Location dowels (x2)
- 22** Cylinder head gasket

Remove

1. Progressively remove the cylinder head bolts in reverse order, starting at bolt 18. Note that the bolts **MUST NOT** be re-used. Discard the bolts.
2. Carefully lift the cylinder head from the crankcase. If necessary use a soft face hammer. **DO NOT** use a lever to separate the cylinder head from the crankcase. Discard the head gasket.
3. Using a suitable cleaning agent, carefully remove all traces of the head gasket material from the cylinder head and crankcase mating faces.
Consumable: Cleaner/Degreaser - General purpose solvent based parts cleaner
4. Check the cylinder head and crankcase mating faces for signs of damage and distortion, refer to Technical Data (PIL 15-06).

Special Tool: Torque Wrench (10-100Nm)
(Qty.: 1)

- 4.2. Then, further tighten the bolts, starting with the middle pair and working outwards (in sequence 1- 18) to the 2nd stage pre-torque.
- 4.3. Then, re-tighten the bolts, starting with the middle pair and working outwards (in sequence 1-18) to the 3rd stage pre-torque.
- 4.4. Use the angle gauge to angle tighten the bolts, starting with the middle pair and working outwards (in sequence 1-18) to the 4th stage pre-torque. As a visual check, matchmark the bolts to the cylinder head before you start. When the bolts have been angle tightened, the matchmarks will appear as shown at Y.
- 4.5. Finally, angle tighten the bolts, starting with the middle pair and working outwards (in sequence 1- 18) for the final stage torque.

Before Assembly

1. Obtain the correct new cylinder head bolts. Note that the original bolts **MUST NOT** be re-used.
2. Obtain the correct replacement head gasket. Note the number of identification holes as shown at X.
3. Make sure that all items are clean and free from damage and corrosion.

Table 34.

Description	Torque Value
Cylinder head to crankcase bolts 1-18	
- first stage torque	40N·m
- second stage torque	75N·m
- third stage torque	75N·m
- fourth stage torque	90°
- final stage torque	180°

Assemble

The cylinder head bolts are tightened using a torque and angle method, refer to Fasteners and Fixings, General, Introduction (PIL 72-00).

1. Replacement is the reversal of the removal procedure.
2. Make sure that the location dowels are correctly installed into the crankcase. Use a dowel punch to install the dowels as required.
3. Position a new head gasket on to the crankcase mating face. Make sure that the gasket is installed the correct way around and correctly located over the dowels.
4. Lower the cylinder head on to the crankcase. Make sure that the cylinder head is correctly located on the dowels. Install new cylinder head bolts. Tighten the bolts in five stages, use the torque and angle method, refer to Fasteners and Fixings, General, Introduction (PIL 72-00).
 - 4.1. Tighten the bolts, starting with the middle pair and working outwards (in sequence 1-18) to the 1st stage pre-torque.

Buy Now



Our support email:

ebooklibonline@outlook.com