



SERVICE MANUAL

SKIDSTEER LOADER
**225, 225T, 260, 260T, 280,
300, 300T, 320T, 325T, 330**

EN - 9813/5150 - ISSUE 2 - 09/2018

This manual contains original instructions, verified by the manufacturer (or their authorized representative).

Copyright 2017 Â© JCB SERVICE
All rights reserved. No part of this publication may be reproduced, stored in a retrieval system, or transmitted in any form or by any other means, electronic, mechanical, photocopying or otherwise, without prior permission from JCB SERVICE.

www.jcb.com

Foreword

The Operator's Manual

⚠
You and others can be killed or seriously injured if you operate or maintain the machine without first studying the Operator's Manual. You must understand and follow the instructions in the Operator's Manual. If you do not understand anything, ask your employer or JCB dealer to explain it.

Do not operate the machine without an Operator's Manual, or if there is anything on the machine you do not understand.

Treat the Operator's Manual as part of the machine. Keep it clean and in good condition. Replace the Operator's Manual immediately if it is lost, damaged or becomes unreadable.

Contents

- 01 - Machine**
- 03 - Attachments, Couplings and Load Handling**
- 06 - Body and Framework**
- 09 - Operator Station**
- 12 - Heating, Ventilating and Air-Conditioning (HVAC)**
- 15 - Engine**
- 18 - Fuel and Exhaust System**
- 21 - Cooling System**
- 24 - Brake System**
- 27 - Driveline**
- 30 - Hydraulic System**
- 33 - Electrical System**
- 72 - Fasteners and Fixings**
- 75 - Consumable Products**
- 78 - After Sales**

Component Identification

Figure 205.

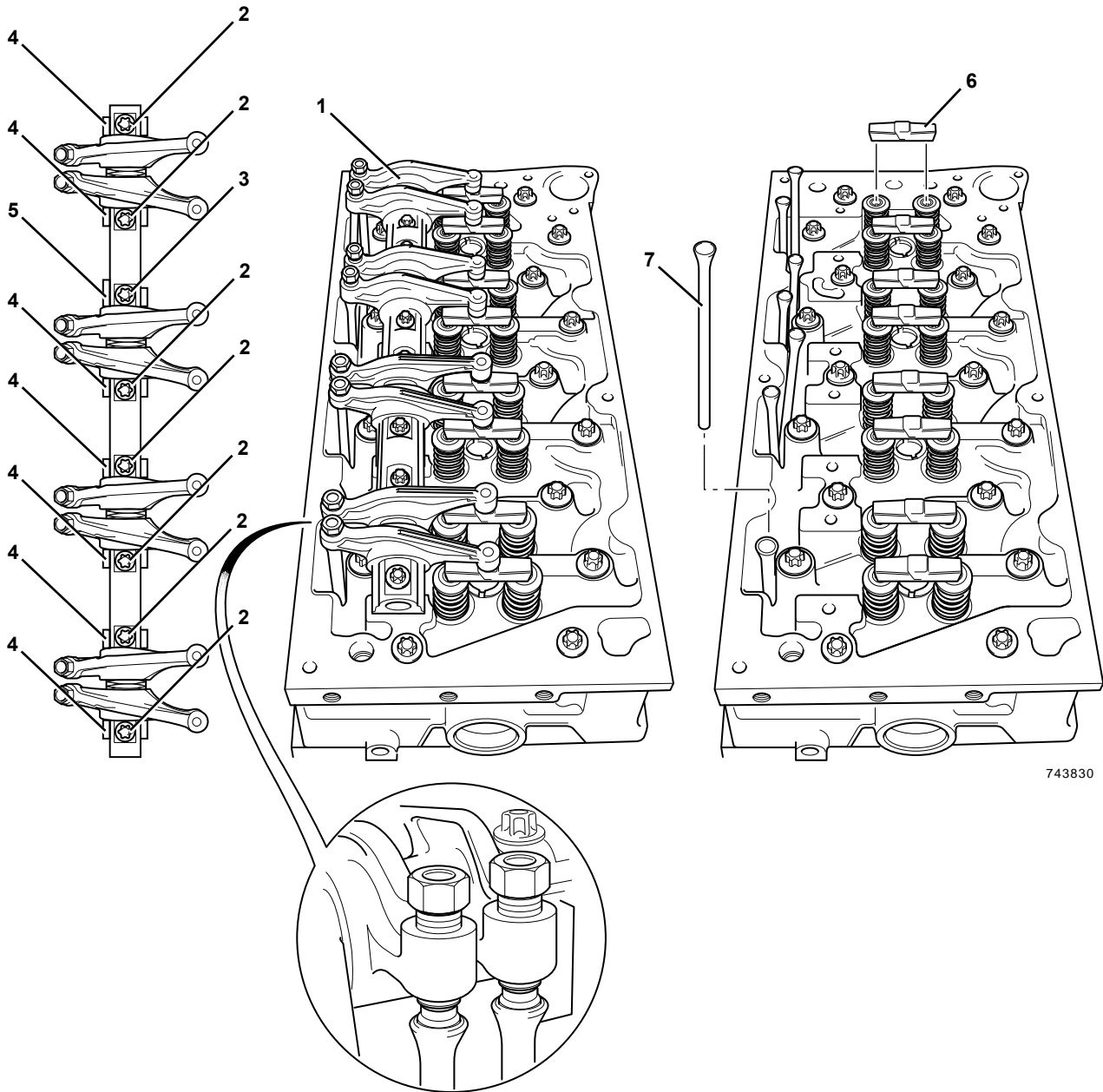

743830

- | | | | |
|---|---|---|--------------------------------|
| 1 | Rocker shaft assembly | 2 | Rocker shaft fixing bolts (x7) |
| 3 | Rocker shaft - oil feed pedestal fixing bolt (x1) | 4 | Pedestals (x7) |
| 5 | Oil feed pedestal (x1) | 6 | Bridge pieces (x8) |
| 7 | Push rods (x8) | | |

Operation

(For: JCB Tier 4i /T4F <55kW Engine 4 Cyl)

When the camshaft lobe raises the outside of the rocker arm, the inside presses down on the valve

stem to open the valve. When the outside of the rocker arm is permitted to return due to the camshafts rotation, the inside rises to allow the valve spring to close the valve.

Figure 206.

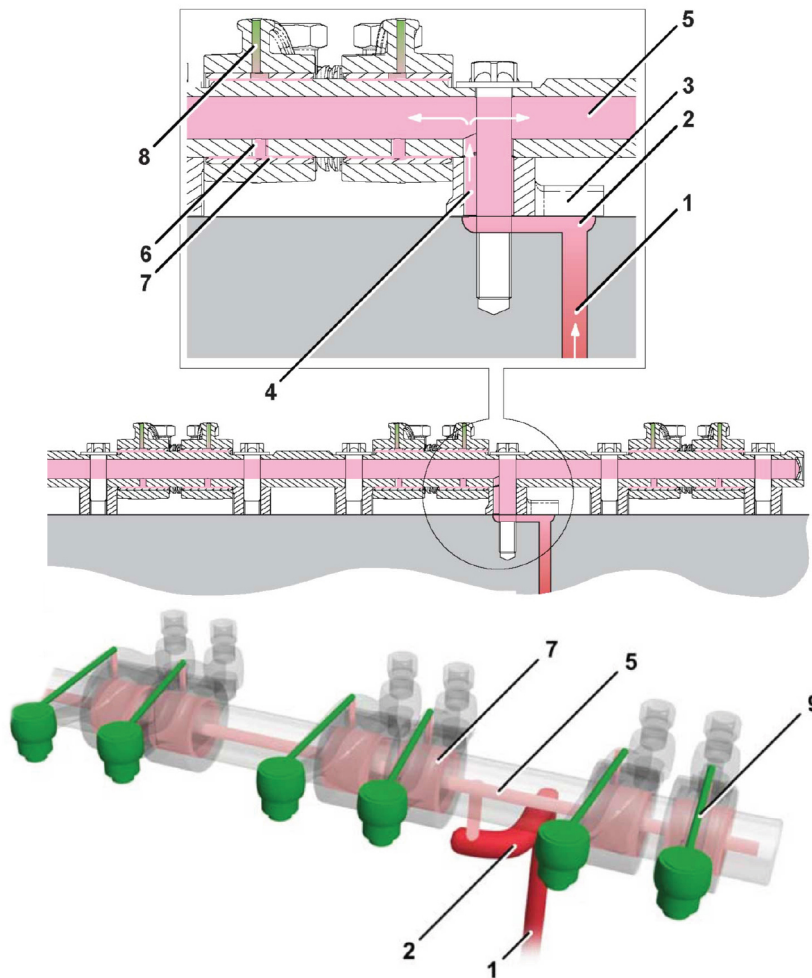

- 1 Oil feed from main gallery
- 3 Shaft pedestal
- 5 Centre rocker shaft drilling
- 7 Rocker pivot bushes
- 9 Groove

- 2 Small transfer gallery
- 4 Rocker shaft fixing bolt hole
- 6 Cross drillings
- 8 Cross drilling

Lubrication

Oil is fed from the main gallery via a drilling which passes up through the crankcase and the cylinder head to a small transfer gallery under the rocker shaft pedestal. The oversized rocker shaft fixing bolt hole allows oil to pass into a drilling in the centre of

the rocker shaft. Further cross drillings transfer oil to each of the rocker pivot bushes. A cross drilling in each rocker transfers oil to the top of the rocker where it flows by gravity along a groove to the rocker tip.

Check (Condition)

1. Check the rocker shaft and rocker bushings for signs of damage and excessive wear. Measure the rocker shaft diameter and rocker bearing bushes to confirm they are within service limits. Refer to Technical Data. Note: The rocker bearing bushes are not renewable. If a rocker bearing bush is damaged or worn the rocker must be renewed as a complete assembly.

[Refer to: PIL 15-42.](#)

2. Make sure that all oil-ways and cross drillings in the rocker shaft, rocker arms and pedestals are clear and free from debris. Use an air line to blow through cross drillings.

Remove and Install

Before Removal

1. Make sure that the engine is safe to work on. If the engine has been running, let it cool before you start the service work.
2. Get access to the engine.
3. Disconnect and remove the fuel pipes from the fuel injectors, refer to Fuel pipes (PIL 18-96).
4. Remove the rocker cover, refer to (PIL 15-42).

Figure 207.

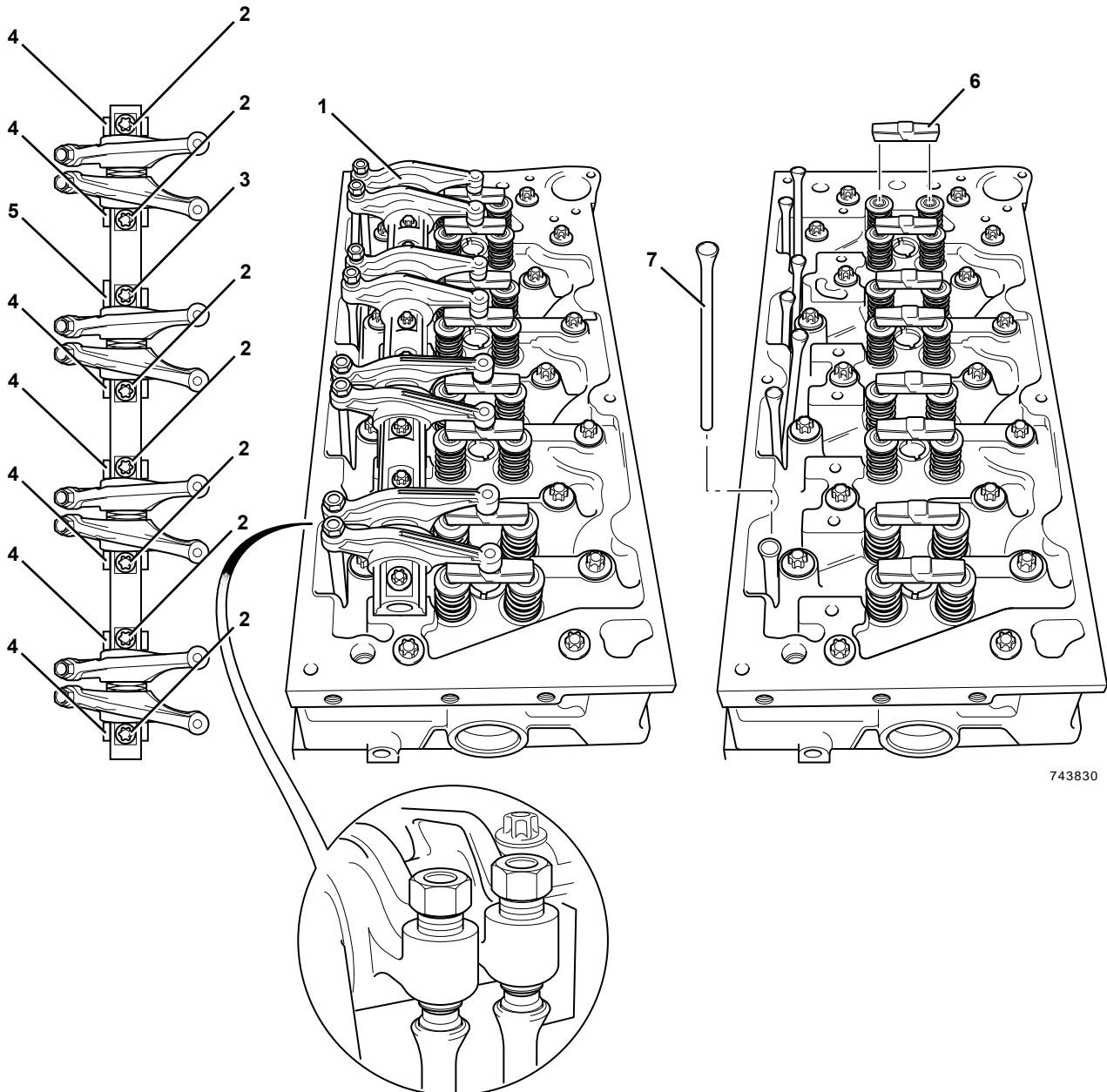

743830

- | | |
|---|----------------------------------|
| 1 Rocker shaft assembly | 2 Rocker shaft fixing bolts (x7) |
| 3 Rocker shaft - oil feed pedestal fixing bolt (x1) | 4 Pedestals (x7) |
| 5 Oil feed pedestal (x1) | 6 Bridge pieces (x8) |
| 7 Push rods (x8) | |

Remove

1. Remove the rocker shaft fixing bolts. DO NOT withdraw the bolts. Lift the rocker shaft assembly from the cylinder head complete with pedestals still attached. Important: Keep all pedestals and fixing bolts in their original positions.
2. Lift off the bridge pieces from the pairs of inlet and exhaust valves.
3. Withdraw the push rods from the cylinder block.

Before Installation

1. Make sure that all items are clean and free from damage and corrosion. Refer to Check Condition (PIL 15-42).
2. Make sure that all oil-ways and cross drillings in the cylinder head, rocker shaft and pedestals are clear and free from debris. Use an air line to blow through the cross drillings.

Install

1. The installation procedure is the opposite of the removal procedure. Additionally do the following steps.
2. Use a suitable degreasing agent to clean the top of the cylinder head.
3. Install the bridge pieces on to the pairs of inlet and exhaust valves in the cylinder head.
4. Insert the push rods into the cylinder block. Make sure that they engage with the camshaft tappets.
5. Install the rocker shaft assembly into the cylinder head. Make sure that the pedestals are located in their original positions. Note the position of the oil feed pedestal and the longer bolt. Make sure that the push rods engage with the tappet adjusters and that the rockers are located over the bridge pieces.
6. Tighten the bolts to the correct torque value.

After Installation

1. Measure and adjust the valve clearances, refer to (PIL 15-30).

Table 68. Torque Values

Item	Nm
2	24
3	24

Disassemble and Assemble

Before Disassembly

1. Remove the rocker cover. Refer to (PIL 15-42).

2. Remove the rocker assembly. Refer to (PIL 15-42).

Figure 208.

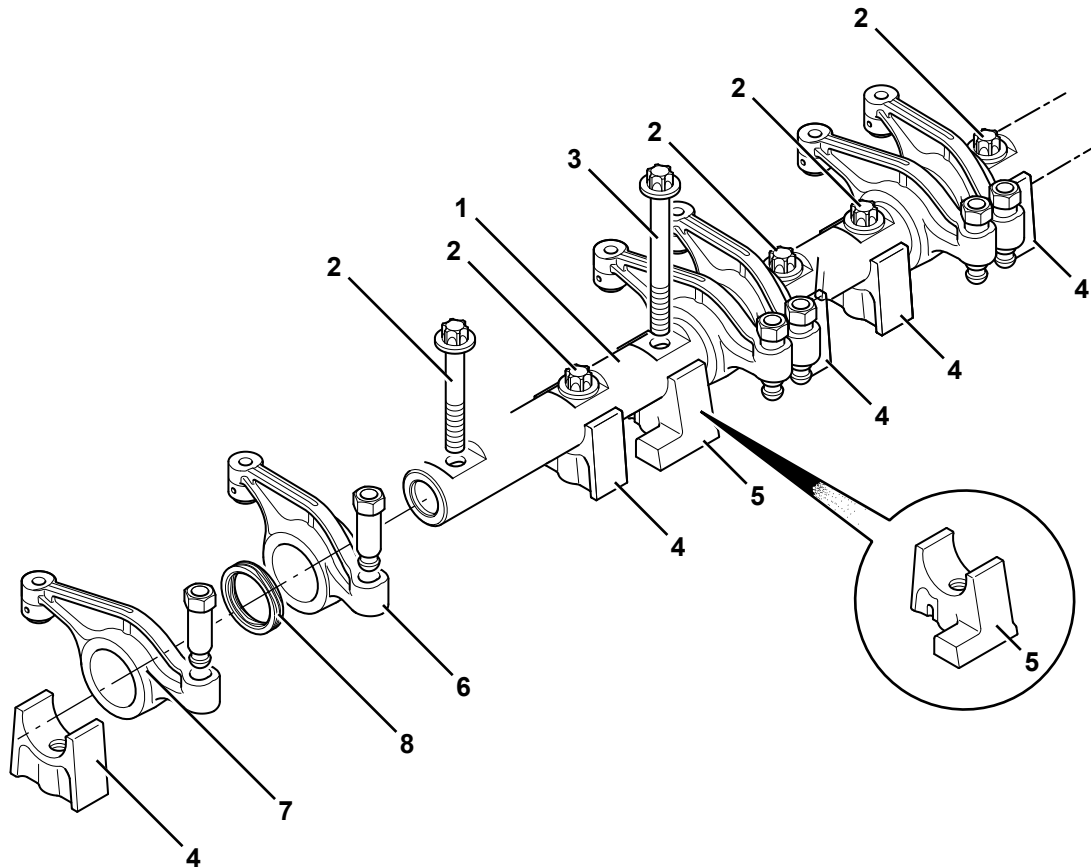

- 1 Rocker shaft
- 3 Rocker shaft - Oil feed pedestal fixing bolt (x1)
- 5 Oil feed pedestal (x1)
- 7 Rockers - exhaust (x4)

- 2 Rocker shaft fixing bolts (x7)
- 4 Pedestals (x7)
- 6 Rockers - inlet (x4)
- 8 Wave washers (x8)

Disassemble

1. Lift out the rocker shaft fixing bolts, then slide the pedestals, rockers and wave washers off the rocker shaft as shown. Label the pedestals and rockers to make sure that they are installed in the correct positions on assembly.
2. Check the rocker shaft and rocker bushings for signs of damage and excessive wear. Refer to Check (Condition) (PIL 15-42).

Assemble

1. The assembly procedure is the opposite of the disassemble procedure. Additionally do the following steps.
2. Lubricate the rocker shaft and rocker bearing bushes with clean engine oil.
3. Make sure that the rockers and pedestals are installed in their original positions along the rocker shaft. Note the position of the oil feed pedestal.
4. Insert the rocker shaft fixing bolts to hold the rockers and pedestals loosely in position before fitting the assembly into the cylinder head. Note the position of the longer bolt.

After Assembly

1. Install the rocker assembly. Refer to (PIL 15-42).
2. Install the rocker cover. Refer to (PIL 15-42).

06 - Rocker Cover

Remove and Install

For: JCB Tier 4i /T4F <55kW Engine 4 Cyl
 Page 15-187
 For: JCB Tier 2/3 Mech Engine 4 Cyl
 Page 15-188

2. Clean the engine. Refer to Engine - Clean (PIL 15-00).

(For: JCB Tier 4i /T4F <55kW Engine 4 Cyl)

Before Removal

1. Make sure that the engine is safe to work on. If the engine has been running, let it cool before you start the service work.

Figure 209.

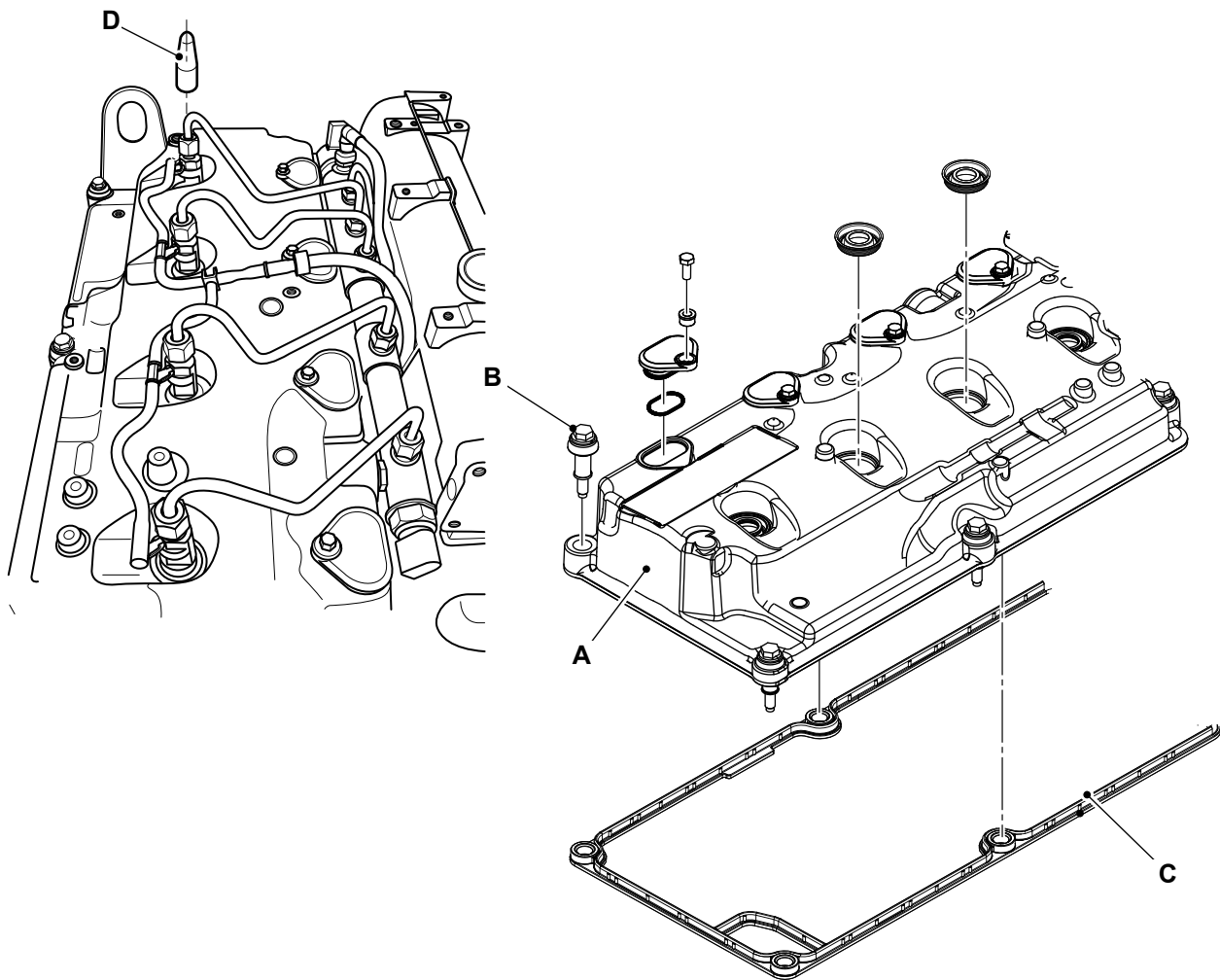

A Rocker cover
C Gasket

B Bolts
D Injector seals

Remove

1. Get access to the engine.
2. Remove the high pressure fuel pipes. Refer to Fuel Pipes (PIL 18-96).
3. Remove the fuel bleed off fuel pipes. Refer to Fuel Pipes (PIL 18-96).
4. Disconnect the electrical connectors at the fuel injectors. Refer to Fuel Injection (PIL 18-18).
5. Disconnect the electrical connector at the coolant temperature sensor. Refer to Engine Sensors (PIL 15-84).
6. Move the electrical harness away from the rocker cover.
7. Remove the bolts and lift the rocker cover from the cylinder head.
8. Discard the gasket.
9. The rocker cover injector seals must be replaced. Refer to Injector seals (PIL 18-18).

Install

1. The installation procedure is the opposite of the removal procedure. Additionally do the following steps.
2. Remove all oil and sludge contamination from inside the rocker chamber.
3. Renew the injector seals. Refer to Injector seals (PIL 18-18).
4. Renew the rocker cover gasket.

5. Prevent damage to the seals. Put sleeves/covers on the four injectors. Apply a rubber lubricant to the seals and then install the rocker cover.
6. Tighten the bolts to the correct torque value.
7. Remove the sleeves/covers.

After Installation

1. The high pressure fuel pipes must be replaced with new parts. Refer to Fuel Pipes (PIL 18-96).
2. Start the engine and check for oil and fuel leaks.

Table 69. Torque Values

Item	Nm
B	24

(For: JCB Tier 2/3 Mech Engine 4 Cyl)

Before Removal

1. Make sure that the engine is safe to work on. If the engine has been running, let it cool before you start the service work.
2. Clean the top of the rocker cover and around the fuel injectors. Refer to Engine - Clean (PIL 15-00).
3. Disconnect and remove the fuel pipes from the injectors.

Refer to: [PIL 18-96](#).

- 3.1. Caps for blanking the open ends of the fuel pipes are supplied with the rocker cover gasket kit.

Figure 210.

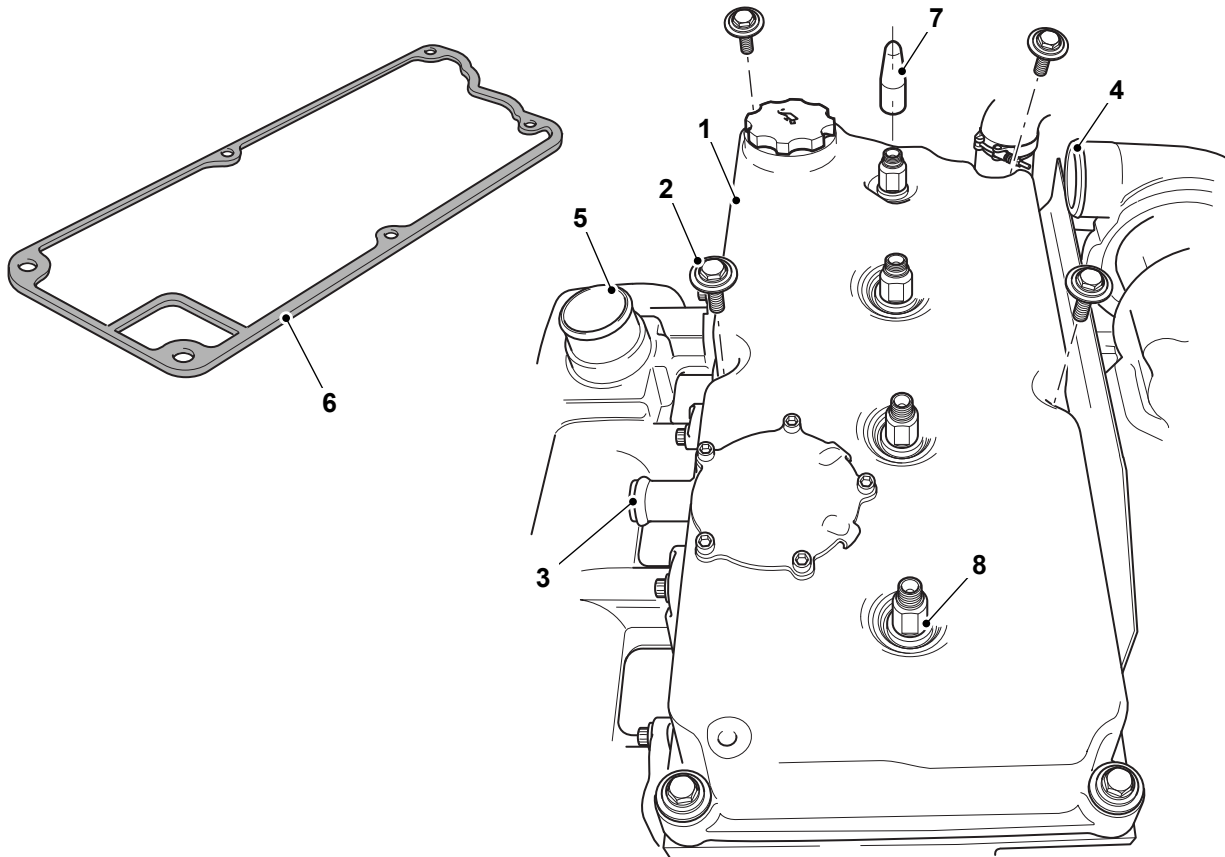

- 1 Rocker cover
- 3 Pipe stub (breather hose)
- 5 Inlet manifold
- 7 Injector sleeves/covers

- 2 Bolts (x6)
- 4 Turbocharger outlet (Turbocharged engines only)
- 6 Gasket
- 8 Rocker cover injector seals

Remove

1. Get access to the engine.
2. Disconnect the breather hose from the pipe stub.
3. Disconnect the air hose from the turbocharger outlet and inlet manifold. Remove the hose. (For Turbocharged Engine Only)
4. Remove the bolts and lift the rocker cover from the cylinder head.
5. Discard the gasket.
6. Put the sleeves/covers over the injectors.
7. The rocker cover injector seals must be replaced. Refer to Injector seals (PIL 18-18).

Install

1. The installation procedure is the opposite of the removal procedure. Additionally do the following steps.
2. Remove all oil and sludge contamination from inside the rocker chamber.
3. Install new the injector seals. Refer to Injector seals (PIL 18-18).
4. Install new the rocker cover gasket.
5. Prevent damage to the seals. Put sleeves/covers on the four injectors. Apply a rubber lubricant to the seals and then install the rocker cover.
6. Tighten the bolts to the correct torque value.
7. Remove the sleeves/covers.

After Installation

1. Connect the fuel pipes to the injectors.
[Refer to: PIL 18-96.](#)
2. Start the engine and check for oil and fuel leaks.

Table 70. Torque Values

Item	Nm
B	24

21 - Tappet

Remove and Install

For: JCB Tier 4i /T4F <55kW Engine 4 Cyl
..... Page 15-193
For: JCB Tier 2/3 Mech Engine 4 Cyl
..... Page 15-194

(For: JCB Tier 4i /T4F <55kW Engine 4 Cyl)

Before Removal

1. Drain the oil from the engine.
2. Disconnect and remove the fuel pipes from the injectors. Refer to (PIL 18-96).
3. Remove the rocker cover. Refer to (PIL 15-42).
4. Remove the fuel injection pump. Refer to (PIL 18-18).
5. Remove the rocker assembly and push rods. Refer to (PIL 15-42).
6. Remove the starter motor. Refer to (PIL 15-75).
7. Remove the oil sump. Refer to (PIL 15-45).
8. Remove the flywheel. Refer to (PIL 15-54).
9. Remove the flywheel housing. Refer to (PIL 15-54).
10. Rotate the crankshaft until the camshaft timing pin can be inserted through the gear and into the aligning hole in the rear gear case.

Figure 211.

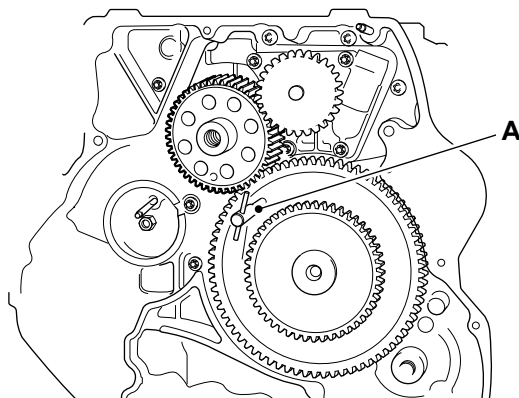

A Timing pin - camshaft

11. Remove the taper blanking plug and insert the crankshaft locking pin. The camshaft and crankshaft locking pins must be in position to lock the crankshaft and camshaft before removing the camshaft assembly.

Figure 212.

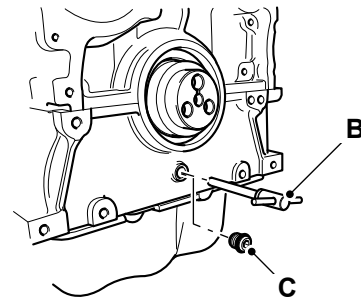

B Timing pin - crankshaft
C Blanking plug

12. Remove the fuel injection pump drive gear. Refer to (PIL 15-51).

Removal

The engine must be inverted. DO NOT attempt to remove the camshaft and its drive gears with the engine upright. The tappets and push rods will fall into the engine and further dismantling will be required to retrieve them.

1. Remove the camshaft timing pin.
2. Carefully withdraw the camshaft and gear assembly from the crankcase. Make sure you fully support the camshaft to prevent the lobes contacting the bearing surfaces in the crankcase. The bearing surfaces can easily be damaged by the sharp hard edges on the cam lobes.

Figure 213.

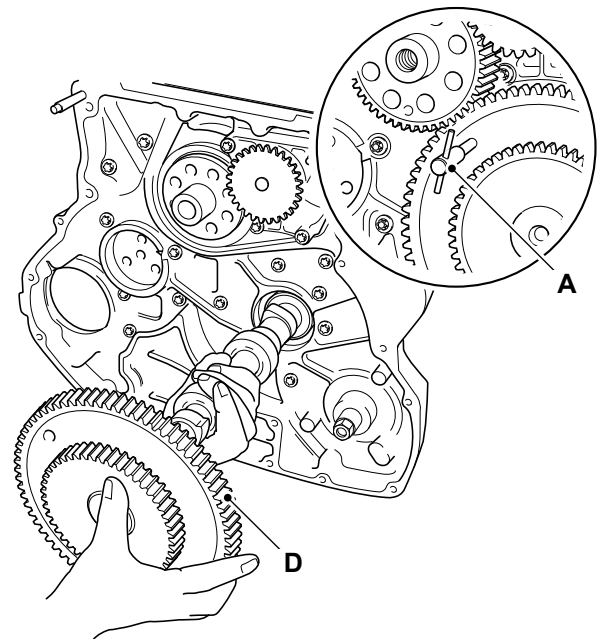

A Timing pin - camshaft
D Camshaft and drive gear

3. Access the tappets through the apertures in the crankcase bedplate next to the crankshaft. Lift out the tappets from the crankcase using a suitable magnetic probe. Label the tappets to ensure replacement in their original positions.

Figure 214.

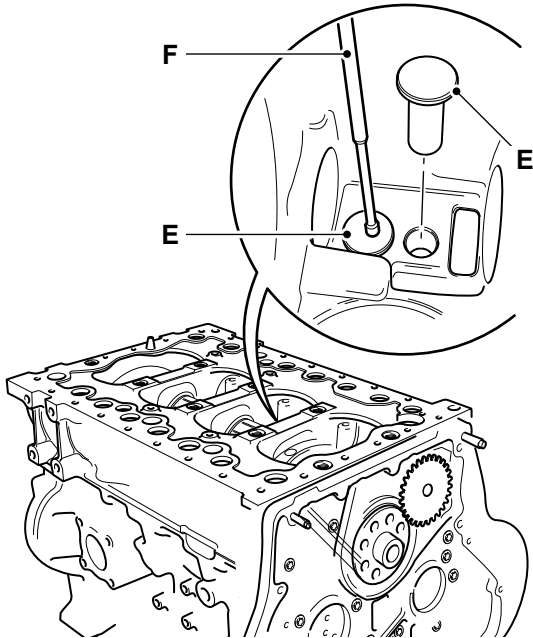

E Tappet (8 off)
F Magnetic probe

Inspection

1. Inspect the camshaft gear teeth for signs of damage or excessive wear.
2. Inspect the cam lobes for signs of excessive wear, scoring or pitting.
3. Inspect the cam bearing surfaces for signs of excessive wear, or scoring. Check that the dimensions are within service limits.
4. Inspect the cam bearing surfaces inside the crankcase for signs of excessive wear, or scoring. Check that the dimensions are within service limits.
5. Inspect the bearing surfaces of the tappets for signs of excessive wear or damage. Check that the dimensions are within service limits.
6. Inspect the tappet bores inside the crankcase for signs of excessive wear or damage. Check that the dimensions are within service limits.
7. If any of the camshaft bearings or lobes are worn or damaged then the relative oil feed galleries in the crankcase and camshaft may be blocked. Make sure all oil ways are clear and free from debris.

Installation

1. Lubricate the tappets and tappet bores inside the crankcase with clean engine oil.
2. Insert the tappets in their original positions in the crankcase using a suitable magnetic probe.
3. Lubricate the camshaft bearing journals inside the crankcase with clean engine oil.
4. Carefully insert the camshaft assembly into the crankcase as shown. Support the camshaft preventing the lobes contacting the bearing surfaces in the crankcase. Before meshing the camshaft gear with the crankshaft gear, rotate the camshaft until the timing hole in the gear aligns with the dowel hole in the gear casing. Insert the timing pin to lock the camshaft in this position.

After Installation

1. Note that the fuel injection pump drive gear fixing nut is torque tightened as part of the fuel injection pump replacement procedure. Refer to (PIL 18-18).
2. Do the procedures in Before Removal in reverse order.

(For: JCB Tier 2/3 Mech Engine 4 Cyl)

Special Tools

Description	Part No.	Qty.
Crankshaft / Camshaft Timing Pin (444/448/672 Engine)	892/01148	1

Before Removal

1. Drain the oil from the engine.
2. Disconnect and remove the fuel pipes from the injectors.
[Refer to: PIL 18-96.](#)
3. Remove the rocker cover.
[Refer to: PIL 15-42-06.](#)
4. Remove the fuel injection pump.
[Refer to: PIL 18-18-15.](#)
5. Remove the rocker assembly and push rods.
[Refer to: PIL 15-42-09.](#)
6. Remove the starter motor.
[Refer to: PIL 15-75-00.](#)
7. Remove the oil sump.

Buy Now



Our support email:

ebooklibonline@outlook.com