

SERVICE MANUAL

BACKHOE LOADER
3CX, 4CX, 5CX

EN - 9813/6950 - ISSUE 3 - 01/2018

This manual contains original instructions, verified by the manufacturer (or their authorized representative).

Copyright 2018 © JCB SERVICE
All rights reserved. No part of this publication may be reproduced, stored in a retrieval system, or transmitted in any form or by any other means, electronic, mechanical, photocopying or otherwise, without prior permission from JCB SERVICE.

www.jcb.com

Foreword

The Operator's Manual

⚠
You and others can be killed or seriously injured if you operate or maintain the machine without first studying the Operator's Manual. You must understand and follow the instructions in the Operator's Manual. If you do not understand anything, ask your employer or JCB dealer to explain it.

Do not operate the machine without an Operator's Manual, or if there is anything on the machine you do not understand.

Treat the Operator's Manual as part of the machine. Keep it clean and in good condition. Replace the Operator's Manual immediately if it is lost, damaged or becomes unreadable.

Contents

01 - Machine

03 - Attachments, Couplings and Load Handling

06 - Body and Framework

09 - Operator Station

12 - Heating, Ventilating and Air-Conditioning (HVAC)

15 - Engine

18 - Fuel and Exhaust System

21 - Cooling System

24 - Brake System

25 - Steering System

27 - Driveline

30 - Hydraulic System

33 - Electrical System

72 - Fasteners and Fixings

75 - Consumable Products

78 - After Sales



00 - General

Introduction	15-217
Component Identification	15-218
Remove and Install	15-219

Introduction

Flywheels are used to provide continuous energy in systems, where the energy source is not continuous. In such cases, the flywheel stores energy when torque is applied by the energy source, and it releases stored energy when the energy source is not applying torque to it.

In a reciprocating engine, a flywheel is used to maintain constant angular velocity of the crankshaft.

The flywheel, which is mounted on the crankshaft, stores energy when torque is exerted on it by a firing piston, and it releases energy to its mechanical loads when no piston is exerting torque on it.

Component Identification

Figure 329.

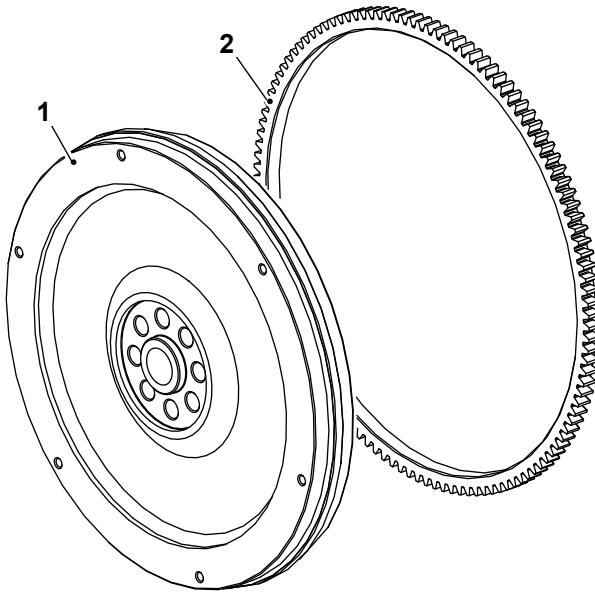

- 1 Flywheel
- 2 Flywheel gear ring

Remove and Install

Before Removal

1. This procedure requires service parts. Make sure you have obtained the correct service parts before you start. The flywheel is installed with a crankshaft position sensor target disc. **DO NOT** remove the target disc. If the disc is defective the flywheel must be replaced.
2. Make sure that the engine is safe to work on. If the engine has been running, let it cool before you start the service work.

3. Get access to the engine.

Removal

1. Remove the bolts and withdraw the flywheel from the crankshaft hub. The bolts **MUST NOT** be reused. Discard the bolts.

Figure 330.

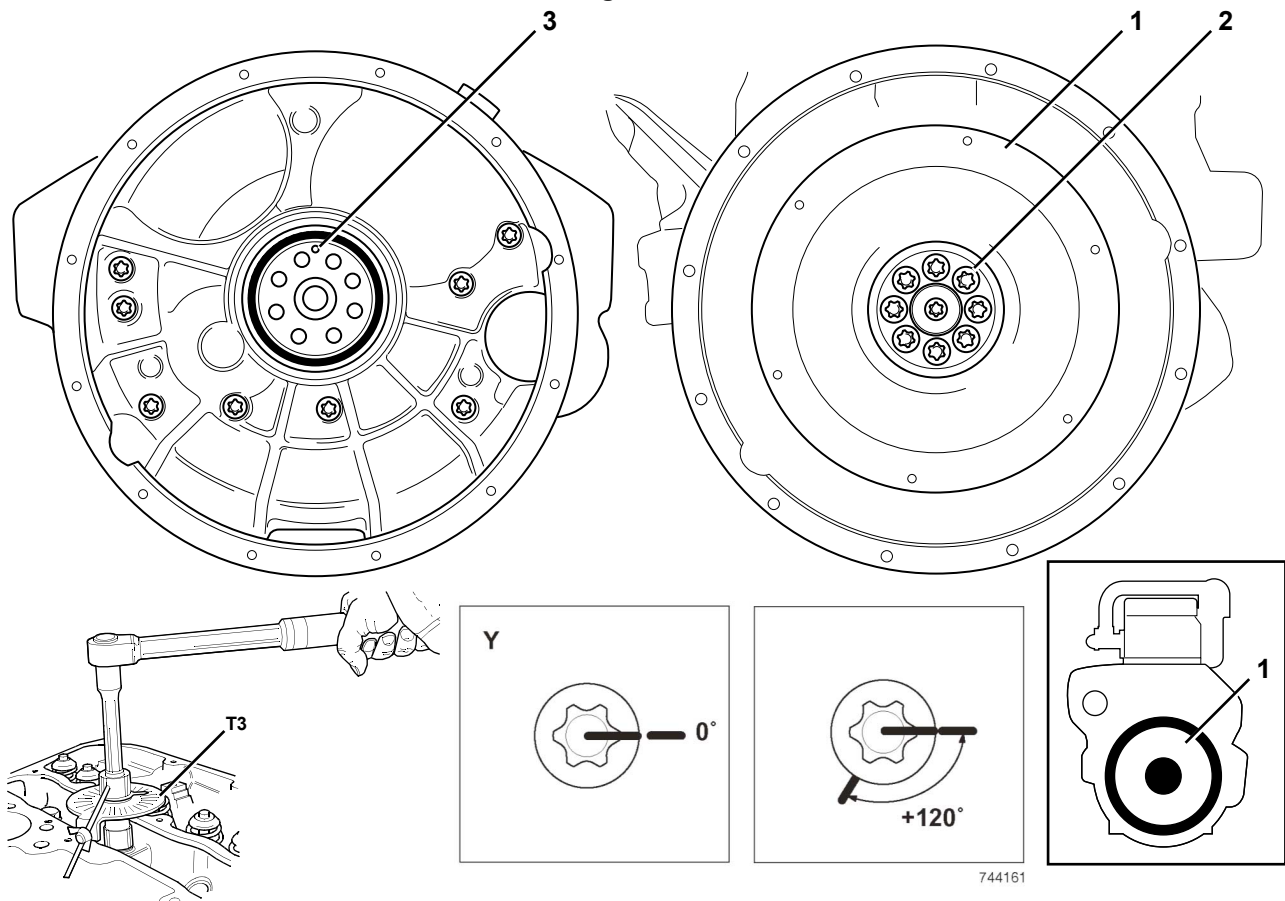

- 1 Flywheel
 3 Flywheel location dowel

- 2 Flywheel fixing bolts (x8)
 Y Angle tightening mark

Installation

1. The installation procedure is the opposite of the removal procedure. Additionally do the following steps.
2. Make sure that all items are clean and free from damage and corrosion.
3. Align the flywheel location dowel.
4. Renew the fixing bolts. Tighten the new bolts to the correct torque value in three stages.

Tighten the bolts in sequence in diagonally opposing pairs. As a visual check, mark the bolts to the flywheel before you start. When the bolts have been angle tightened the marks will appear as at 120°.

Table 111. Torque Table

Item	Torque Value (Nm)	Angle (degrees)
2 (1st Stage)	40	
2 (2nd Stage)	120	
2 (Final Stage)		+120

03 - Housing

Remove and Install

Special Tools

Description	Part No.	Qty.
Template for Sealant Flywheel Housing to Gear Case (4 Cyl Elec)	892/12349	1

Before Removal

The flywheel housing is integral with the drive gears front case. When the housing is removed the drive gears will be exposed. DO NOT attempt to remove the camshaft and the drive gears. Removing the camshaft with the engine in the upright position will cause the tappets to dislodge, requiring the engine block to be dismantled.

1. This procedure requires service parts. Make sure you have obtained the correct service parts before you start.

2. Remove the flywheel. Refer to (PIL 15-54).
3. Remove the starter motor. Refer to (PIL 15-75).

Removal

1. Remove the flywheel housing fixing bolts and then separate the flywheel housing from the gear case.
2. If required, undo the bolts and remove the access cover.
3. Remove and discard the crankshaft rear oil seal. Take care not to damage the seal bore in the housing.

Figure 331.

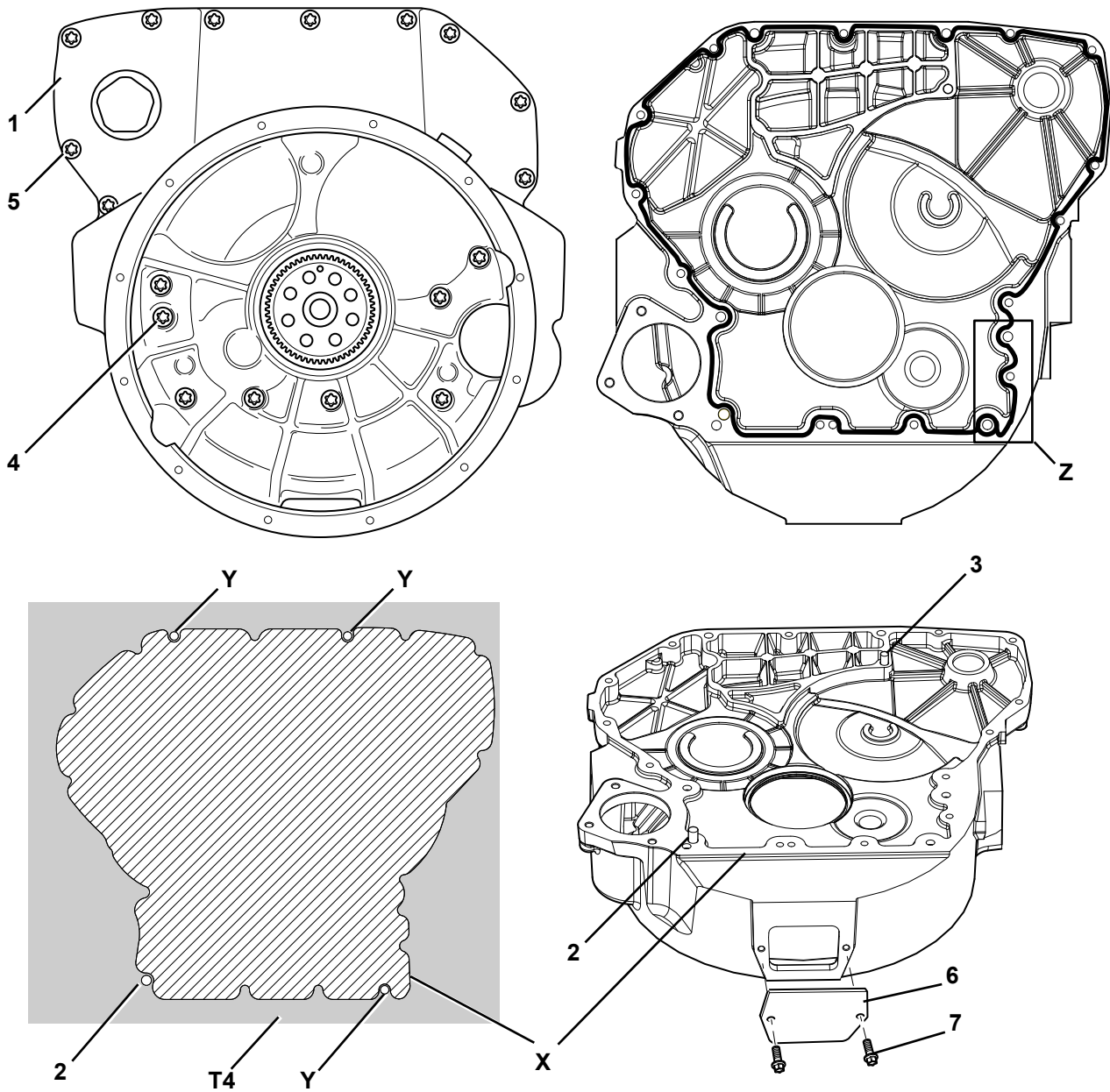

- | | | | |
|----|--|----|--|
| 1 | Flywheel housing | 2 | Dowel - 12 mm |
| 3 | Dowel - 10 mm | 4 | Flywheel housing fixing bolts (x6) M10 |
| 5 | Flywheel housing fixing bolts (x12) M8 | 6 | Access cover |
| 7 | Access cover fixing bolts (x2) | Y | Fixing point |
| X | Flywheel housing mating face | Z | Alternative fixing holes |
| T3 | Alignment pins | T4 | Sealant template |

Before Installation

1. Carefully remove all traces of the old sealant compound from the flywheel housing mating faces.

2. Use a suitable degreasing agent to clean the inside of the flywheel housing.

3. Carefully inspect all gears, bearings and shafts for signs of excessive wear or damage. If wear or damage is evident, the components must be renewed.

Installation

Anaerobic sealant will not start to cure whilst it is open to the atmosphere, however when air is excluded (for instance when the two parts are put together) it will immediately start to harden. Make sure that all the necessary tools, bolts etc. are readily available prior to assembling the components. The parts must be installed and torque tightened within 5min with a maximum permissible time of 15min

1. The installation procedure is the opposite of the removal procedure. Additionally do the following steps.
2. Make sure that all items are clean and free from damage and corrosion.
3. Make sure that the dowels are installed to the mating face of the flywheel housing.
4. Install the sealant template T4 on the housing. Locate the holes in the template, use the dowel and three fixing bolts in the fixing points.
[Special Tool: Template for Sealant Flywheel Housing to Gear Case \(4 Cyl Elec \) \(Qty.: 1\)](#)
5. Use the template T4 as a guide, apply a continuous bead of sealant around the flywheel housing mating face
Length/Dimension/Distance: 1.5mm
 - 5.1. Some engines feature a flywheel housing with a different fixing hole pattern. Use the template to apply the sealant but apply sealant manually in the position shown at Z.
6. Remove the three fixing bolts at positions. Remove the template T4, make sure not to smudge the sealant. Discard the template.
7. Locate the flywheel housing on the alignment pins T3 on the crankcase and install the fixing bolts. Progressively tighten the bolts to the correct torque value.
 - 7.1. Remove the alignment pins to install the last two M10 fixing bolts.
 - 7.2. The parts must be separated, thoroughly cleaned and fresh sealant applied if the parts have not been torque tightened within the maximum time period.
Duration: 15min
8. Install the access cover and use the bolts to secure. Tighten the bolts to the correct torque value. Refer to Table 112.

After Installation

1. Install a new crankshaft rear oil seal.
2. Install the flywheel.
3. Install the starter motor.

Table 112. Torque Values

Item	Nm
4	47
5	24
7	24

09 - Gear Ring

Remove and Install

- ▲ CAUTION** Wear eye protection when you drive the gear ring off the flywheel.

If the flywheel gear teeth are damaged or excessively worn, the gear ring can be replaced with a new one.

Before Removal

1. This procedure requires service parts. Make sure you have obtained the correct service parts before you start.
2. Remove the flywheel from the crankshaft hub.

Figure 332.

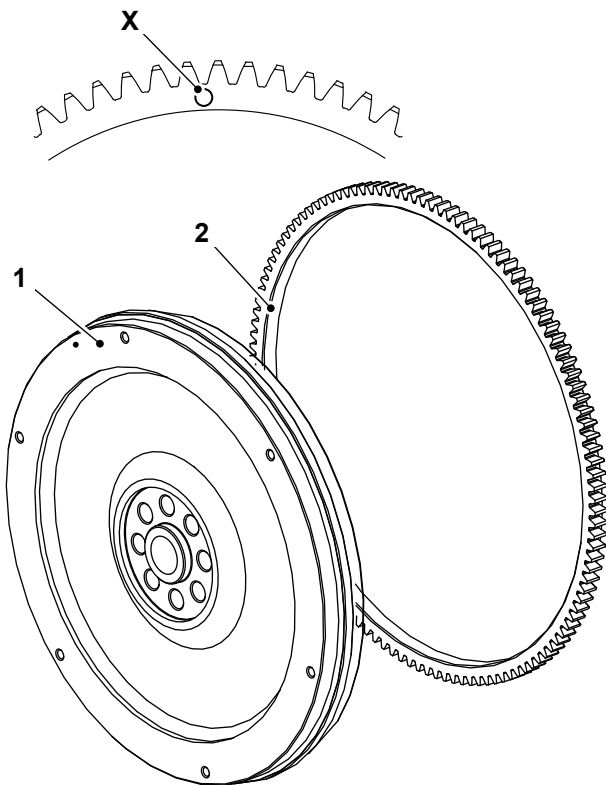

- 1 Flywheel
- 2 Gear ring
- x Position of hole

Removal

1. Note that the gear teeth have a lead-in chamfer on one side to assist the starter motor pinion to engage. Note which way around the gear ring is installed to make sure that the new gear ring is installed the same way on assembly.
2. Place the flywheel flat on a firm surface. Drill a hole through the gear ring below the root of one

of the gear teeth as shown. Drive a chisel into the adjacent tooth to spread the gear ring apart. Take care not to damage the flywheel or the position sensor target disc.

Installation

1. Make sure that all items are clean and free from damage and corrosion.
2. Heat up the new gear ring, preferably in an oven to make sure that the heat is applied evenly around the circumference. Do not heat the gear ring above
Temperature: 200°C (391.7°F)
3. When sufficiently heated, install the gear ring into position over the flywheel. Make sure that the gear ring is installed the correct way around.

After Installation

1. Install the flywheel to the crankshaft hub.

00 - General

Introduction	15-227
Component Identification	15-228
Check (Condition)	15-230
Remove and Install	15-231

Introduction

The oil pump is a rotor type pump located inside the timing gear case. The pump is driven by gears via the crankshaft.

The pump consists of two rotors, one running inside the other. The outer rotor has one more lobe than the inner rotor and turns on a different axis.

When rotated the gap between the inner and outer rotor lobes increases, drawing oil in through the inlet port. After a half rotation the gap reaches a maximum, the inlet port is closed and the outlet port opens.

Further rotation causes the gap between the lobes to diminish, forcing the oil out through the outlet port.

A pressure relief valve assembly is integral with the pump body. As oil pressure increases it acts on a spool to overcome the pressure of the spring. As the spool moves it uncovers a port allowing pressurised oil directly back to the inlet port. In practice the spool is continually opening and closing to maintain the correct oil pressure value. The valve is not adjustable.

Component Identification

Figure 333.

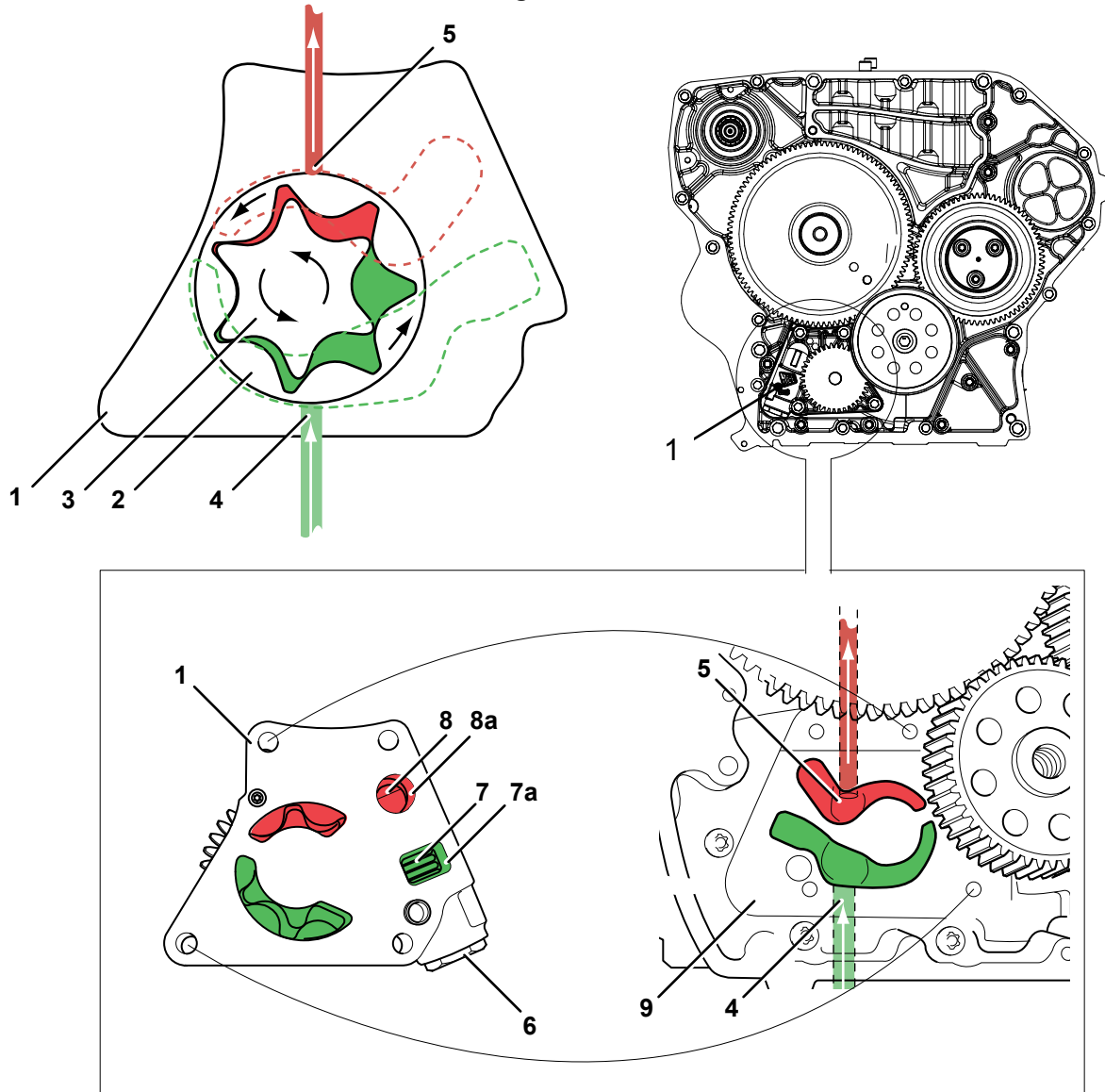

- 1 Oil pump
- 3 Inner rotor
- 5 Outlet port
- 7 Relief valve spring
- 8 Relief valve spool
- 9 Oil pump connecting ports (engine bed plate)

- 2 Outer rotor
- 4 Inlet port
- 6 Relief valve assembly
- 7a Relief valve port (return to inlet port 4)
- 8a Relief valve pressure port (connected to port 5)

Figure 334.

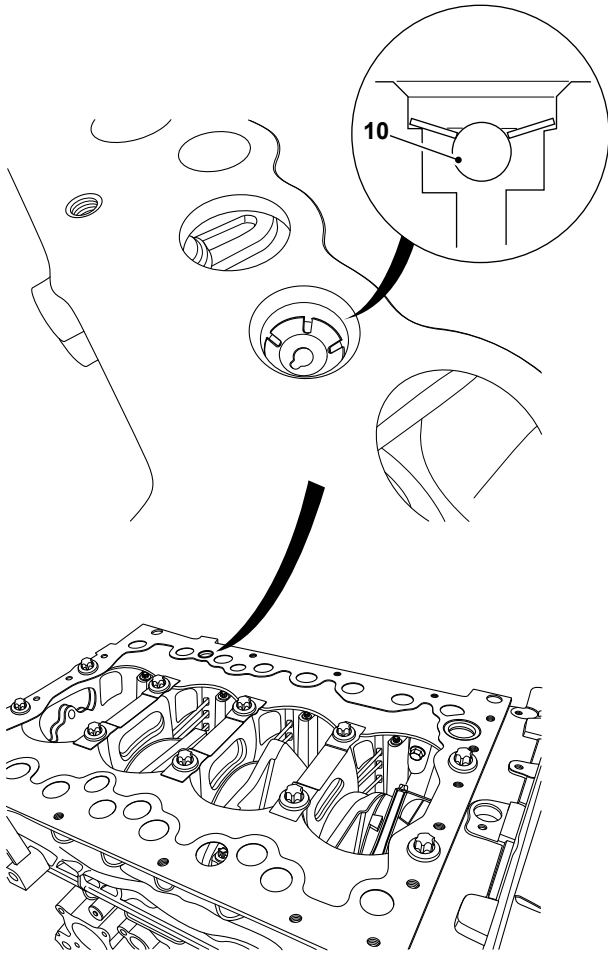

10 CCV Anti drain back valve

Check (Condition)

1. Check the oil pump internal parts for signs of damage and excessive wear.
2. Use feeler gauges to measure the inner and outer rotor clearance, and the rotor end float to confirm they are within service limits.

[Refer to: PIL 15-12-00.](#)

Remove and Install

Special Tools

Description	Part No.	Qty.
Torque Wrench (10-100Nm)	993/70111	1

The illustrations show the engine inverted. If the oil pump is being removed prior to crankshaft or camshaft removal, the engine must be inverted. If the oil pump only is being removed (for inspection or renewal) then the engine need not be inverted.

This procedure requires service parts. Make sure you have obtained the correct service parts before you start, refer to Parts Catalogue.

Before Removal

1. Make sure that the engine is safe to work on. If the engine has been running, let it cool before you start the service work.
2. Drain the oil from the engine, refer to (PIL 15-21).
3. Remove the starter motor, refer to (PIL 15-75).
4. Remove the flywheel, refer to (PIL 15-54).
5. Remove the flywheel housing, refer to (PIL 15-54).

Figure 335.

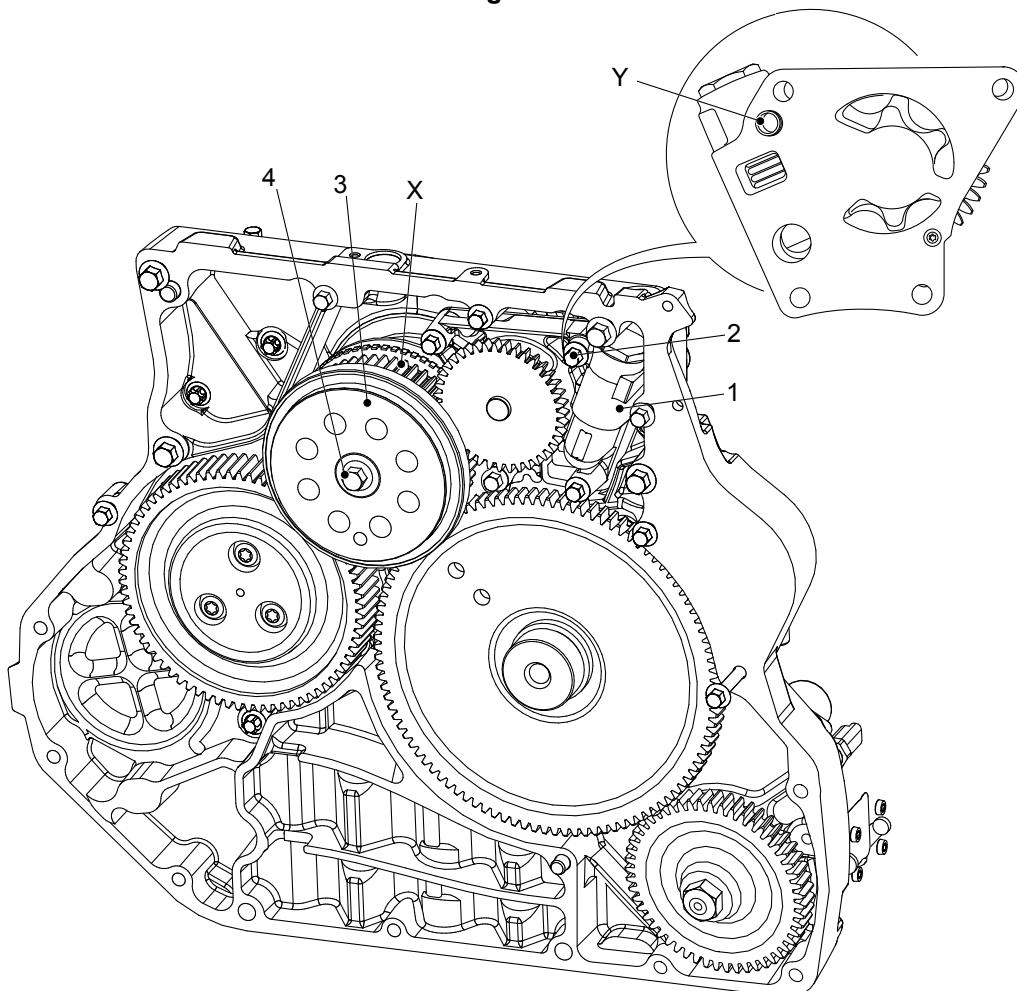

- 1 Oil pump
- 3 Flywheel hub
- X Crankshaft gear

- 2 Oil pump fixing bolts (x4)
- 4 Flywheel hub fixing bolt
- Y Oil pump location dowel

Buy Now



Our support email:

ebooklibonline@outlook.com