

SERVICE MANUAL

EXCAVATOR
JS200, JS210, JS220, JS235

EN - 9813/7250 - ISSUE 1 - 05/2017

This manual contains original instructions, verified by the manufacturer (or their authorized representative).

Copyright 2017 © JCB SERVICE
All rights reserved. No part of this publication may be reproduced, stored in a retrieval system, or transmitted in any form or by any other means, electronic, mechanical, photocopying or otherwise, without prior permission from JCB SERVICE.

www.jcb.com

Foreword

The Operator's Manual

You and others can be killed or seriously injured if you operate or maintain the machine without first studying the Operator's Manual. You must understand and follow the instructions in the Operator's Manual. If you do not understand anything, ask your employer or JCB dealer to explain it.

Do not operate the machine without an Operator's Manual, or if there is anything on the machine you do not understand.

Treat the Operator's Manual as part of the machine. Keep it clean and in good condition. Replace the Operator's Manual immediately if it is lost, damaged or becomes unreadable.

Contents

01 - Machine

03 - Attachments, Couplings and Load Handling

06 - Body and Framework

09 - Operator Station

12 - Heating, Ventilating and Air-Conditioning (HVAC)

15 - Engine

18 - Fuel and Exhaust System

21 - Cooling System

27 - Driveline

30 - Hydraulic System

33 - Electrical System

72 - Fasteners and Fixings

75 - Consumable Products

78 - After Sales

00 - General

Introduction	15-119
Technical Data	15-120
Component Identification	15-121
Operation	15-123
Adjust	15-123
Remove and Install	15-126

Introduction

The valve train system opens and closes the valves with correct timing in relation to the piston movements.

Each push rod has one end in a valve tappet and the other end under a rocker arm, or as applicable. The adjusting screw has a ball shaped end that locates in the push rod. The adjusting screw is used for setting the valve clearance.

The valves extend through the cylinder head. There are no sleeves or valve guides in the cylinder head. The valves are made from a special metal to provide a long service life. Damaged or worn valves cannot be lapped or reground and must be replaced with new ones. Each valve stem has an oil seal.

The Valve seat inserts are pressed into the cylinder head. The seat inserts are also made from a special metal to provide for a long service life. Damaged or worn seat inserts can be removed and replaced with new ones.

Technical Data

Table 72. Inlet and Exhaust Valve Data

Max lift Inlet	9.64mm @ 101° ATDC
Max lift Exhaust	9.84mm @ 115° BTDC
Inlet opens (top of ramp)	6° BTDC
Inlet closes	28° ATDC
Exhaust opens	41° BTDC
Exhaust closes	6° ATDC
Valve stem diameter	
- Inlet	6.928–6.943mm
- Exhaust	6.918–6.933mm
Valve spring free length	51.1mm
Valve guide bore diameter	
- min	6.958mm
- max	6.973mm
Valve face angle	
- Inlet	60.5°
- Exhaust	45.17°
Valve length	131.9–132.4mm
Valve sealing	Stem seal with sealing washer
Valve head depth (below cylinder head surface)	
- Inlet	0.89–1.39mm
- Exhaust	0.95–1.45mm
Valve rim thickness	2.98–3.38mm
Valve Clearances (engine cold)	
- Inlet	0.15–0.21mm ⁽¹⁾
- Exhaust	0.43–0.49mm ⁽¹⁾

(1) The values refer to the tappet adjuster end of the valve rockers.

Component Identification

Figure 156.

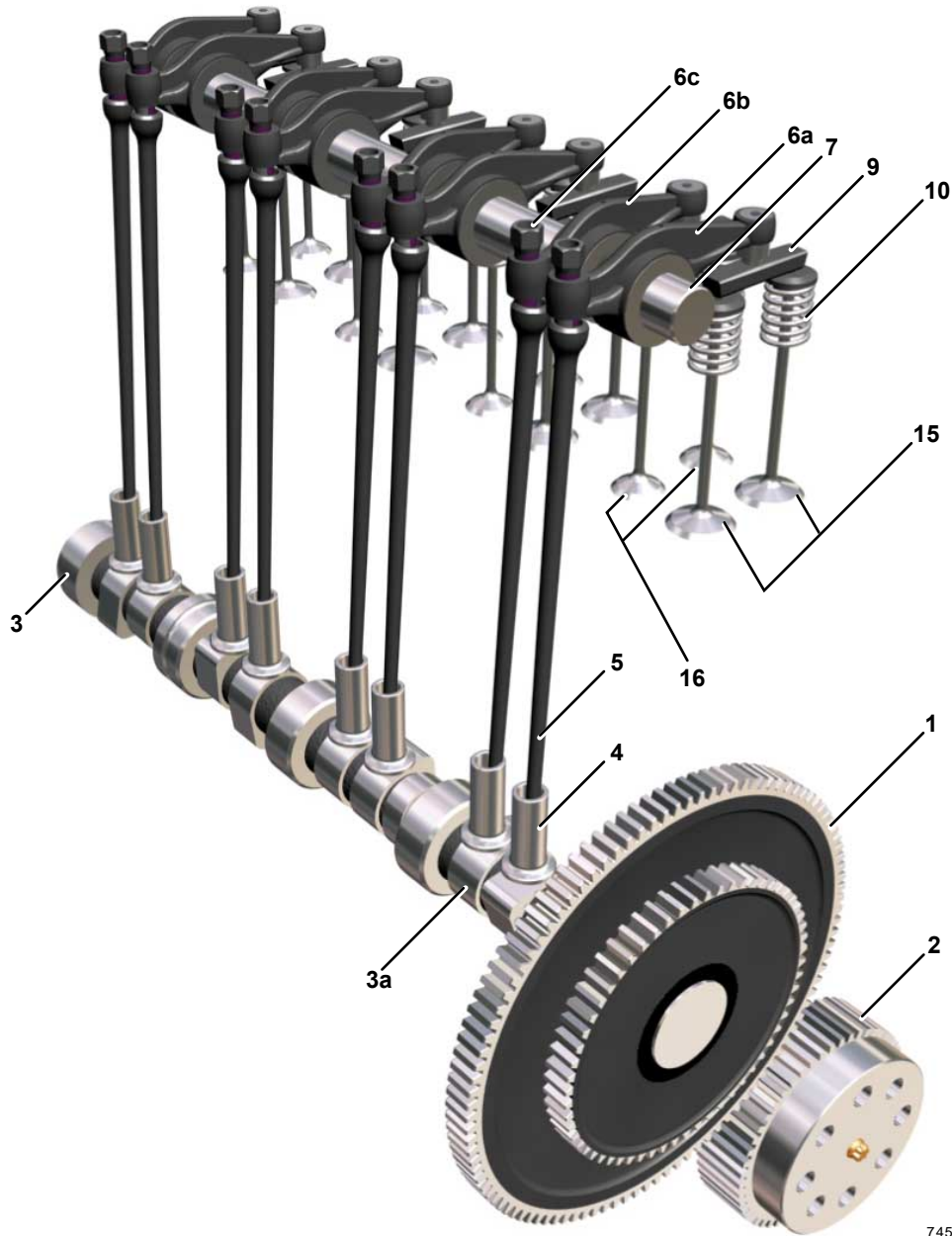

74570C

- 1 Camshaft drive gear
- 3 Camshaft
- 4 Tappets (x8)
- 6a Rockers - inlet (x4)
- 6c Adjusting screws (x8)
- 7 Rocker shaft
- 9 Bridge pieces (x8)
- 11 Retainer (x16)
- 13 Oil seal - valve stems (x16)

- 2 Crankshaft gear
- 3a Lobes
- 5 Push rods (x8)
- 6b Rockers - exhaust (x4)
- 6d Swivel tip - rockers
- 8 Wave washers (x8)
- 10 Valve springs (x16)
- 12 Collets (x32)
- 14 Valve seat inserts (x16)

- 15 Inlet valves (x8)
- 17 Valve stem

- 16 Exhaust valves (x8)

Cross Sectional View

Figure 157.

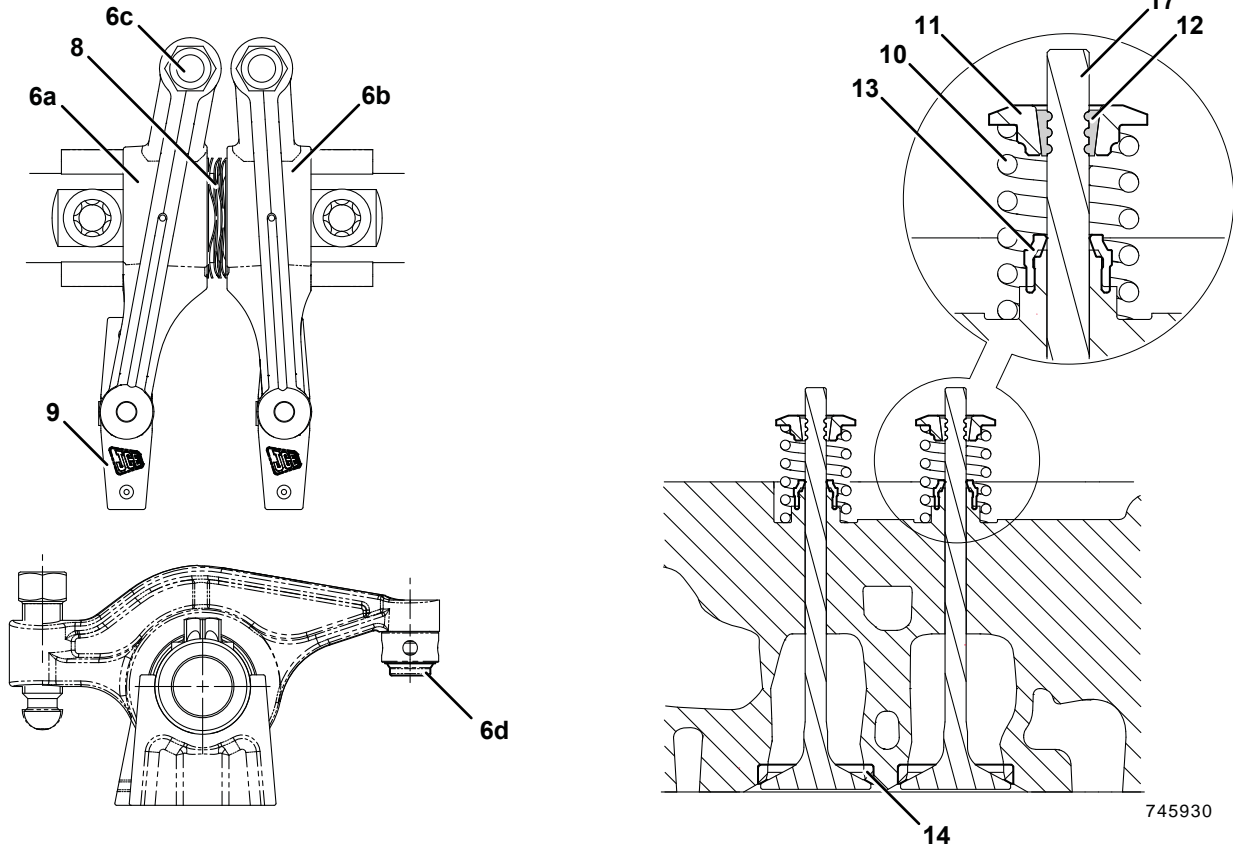

- 6a Rockers - inlet (x4)
- 6c Adjusting screws (x8)
- 8 Wave washers (x8)
- 10 Valve springs (x16)
- 12 Collets (x32)
- 14 Valve seat inserts (x16)

- 6b Rockers - exhaust (x4)
- 6d Swivel tip - rockers
- 9 Bridge pieces (x8)
- 11 Retainer (x16)
- 13 Oil seal - valve stems (x16)
- 17 Valve stem

Operation

The camshaft drive gear is driven by the crankshaft gear at half the speed of the crankshaft. Camshaft lobes, two for each cylinder, (operating exhaust and inlet valves) actuate the valve tappets.

When the camshaft rotates the cam lobes act on the tappets. The push rods act on the rockers which pivot on the camshaft, depressing two valves at the same time via the bridge piece.

The screw is self locking in the rocker by means of a tapered thread. Wave washers act like springs to keep the rockers in their correct positions along the camshaft and prevent them contacting one another. The rockers incorporate a swivel tip to ensure alignment with the bridge piece. This prevents excessive wear.

Each valve has a compression spring. The function of the spring is to close the valve and at the same time return the rocker arm and push rod to ensure that the tappets follow the camshaft lobes. The spring is located on the valve stem by a retainer and split collets.

Adjust

Special Tools

Description	Part No.	Qty.
Crankshaft Turning Tool (95.25mm PCD)- JCB 4 Cylinder Ecomax and Dieselmex	892/01147	1
Valve Clearance Service Kit	892/01380	1

Engine Position

The engine needs to be set to two different positions to measure and adjust all of the valves. The graphics show which valves are applicable at which engine position.

1. Make sure that the engine is safe to work on. If the engine has been running, let it cool before you start the service work.
2. Get access to the engine.
3. Remove the tappet covers. Refer to (PIL 15-42).
4. Put the indicator pins into the holes inside the tappet adjusters for cylinder number 4. Make sure that the pins do not fall into the engine.
5. Use the crankshaft turning tool to turn the engine crankshaft clockwise. Stop turning the crankshaft when one indicator pin starts to move up after the other pin has moved down. This is the position where the exhaust valve is almost closed and the inlet valve is just starting to open.
[Special Tool: Crankshaft Turning Tool \(95.25mm PCD\)- JCB 4 Cylinder Ecomax and Dieselmex \(Qty.: 1\)](#)
[Special Tool: Valve Clearance Service Kit \(Qty.: 1\)](#)
6. Put a mark on the crankshaft pulley at the 12 o'clock position.

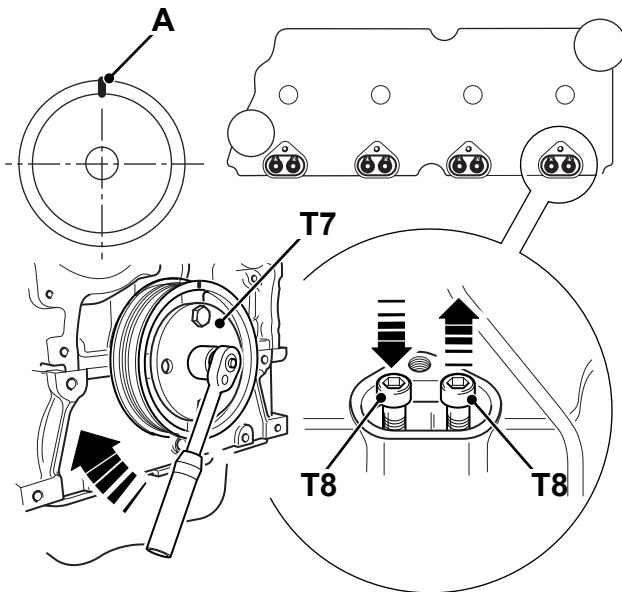
Figure 158.

- A** 12 o'clock position
T7 Crankshaft turning tool
T8 Indicator pins (obtain locally)

7. Turn the engine crankshaft 90 degrees clockwise.
8. Measure and, if necessary, adjust the clearances for the correct valves.

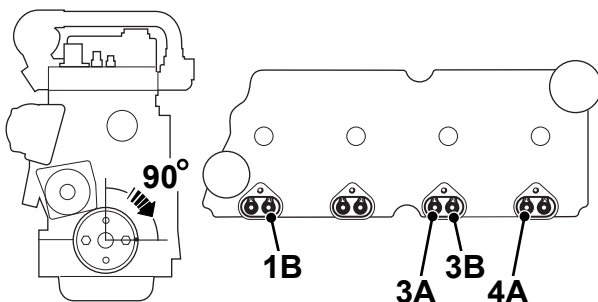
Figure 159. 90 Degree Position

- 1B** Inlet valve-Cylinder 1
3A Exhaust valve-Cylinder 3
3B Inlet valve-Cylinder 3
4A Exhaust valve-Cylinder 4

9. Remove the valve clearance service tools. Turn the engine crankshaft 360 degrees clockwise. Use the mark on the crankshaft pulley as a reference.
10. Measure and, if necessary, adjust the clearances for the correct valves.

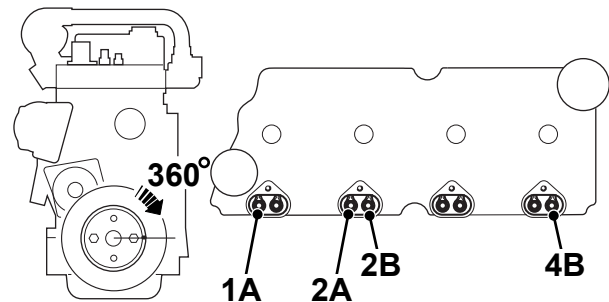
Figure 160. 360 Degree Position

- 1A** Exhaust valve-Cylinder 1
2A Exhaust valve-Cylinder 2
2B Inlet valve-Cylinder 2
4B Inlet valve-Cylinder 4

Valve Clearances

The procedure describes how to measure and, if necessary, adjust one valve clearance. The procedure for all the valves is the same. Do the procedure for the correct valves at each of the two engine positions. Remember you must remove the valve clearance service tools before you turn the engine crankshaft.

Important: The engine must be cold before you measure or adjust the valve clearances.

1. Install the adaptor plate in the correct position on the rocker cover using the screws A.
2. Make sure that the crankshaft is in the correct position.
3. Put the adaptor sleeve on the correct valve tappet adjuster screw.
4. Push the lock bar into the correct valve tappet adjuster screw.
5. Tighten the lock bar by turning it with your hand.
6. Assemble the DTI support and DTI.
7. Push and then pull the lock bar in the direction of the arrows X and Y. Do this until you are sure that the lock bar is correctly installed and oil is moved away from the cam follower and push rod.
8. **Important:** Apply a side force on the lock bar at the same time as pushing and pulling. This prevents the rocker moving along the rocker shaft and giving a false reading on the DTI. Apply a force to the left on the exhaust valve tappets and to the right on the inlet valve tappets.

Figure 161.

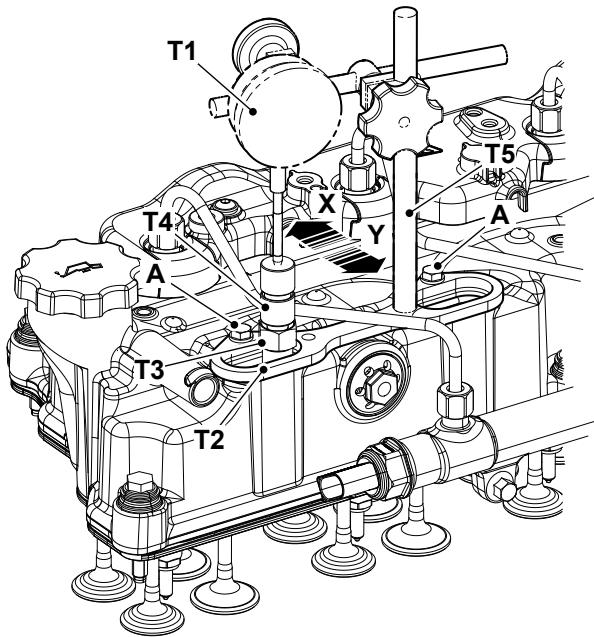

- A** Screws
- T1** Dial Test Indicator (DTI)(obtain locally)
- T2** Adaptor plate (part of valve clearance service kit)
- T3** Adaptor sleeve (part of valve clearance service kit)
- T4** Lock bar (part of valve clearance service kit)
- T5** DTI Support (obtain locally)

Figure 162.

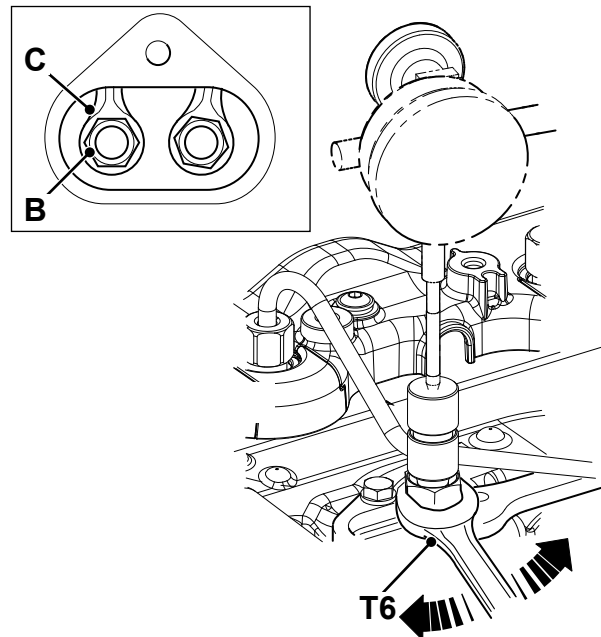

- B** Tappet adjusters
- C** Rockers
- T6** Spanner open ended (obtain locally)

9. Pull the lock bar in the direction of arrow Y and turn the DTI to zero.
10. Push the lock bar in the direction of arrow X and record the DTI indication.
11. Compare the valve clearance measurement with the correct clearances. If an adjustment is necessary:
 - 11.1. Turn the tappet adjuster using an open ended spanner on the adaptor sleeve. Turn the sleeve clockwise to reduce the clearance and counterclockwise to increase the clearance.
 - 11.2. Important: The tappet adjusters are set in position by thread friction with the rockers. Make sure that the torque to turn the tappet adjusters is more than the minimum necessary. If any of the adjusters show a lower torque value then the adjuster and its related rocker must be replaced.

Remove and Install

Special Tools

Description	Part No.	Qty.
Valve Stem Seal Installation Tool (444/448/762 Engine)	892/01152	1

Before Removal

1. This procedure requires service parts. Make sure you have obtained the correct service parts before you start, refer to Parts Catalogue.
2. Make sure that the engine is safe to work on. If the engine has been running, let it cool before you start the service work.
3. Get access to the engine.
4. Remove the thermostat, refer to (PIL 21-12).
5. Remove all of the fuel injector pipes, refer to (PIL 18-96).
6. Remove the rocker cover, refer to (PIL 15-42).
7. Remove the fuel injectors, refer to (PIL 18-18).
8. Remove the rocker assembly, refer to (PIL 15-42).
9. Remove the exhaust manifold, refer to (PIL 18-24).
10. Remove the inlet manifold, refer to (PIL 18-24).
11. Remove the cylinder head assembly from the cylinder block, refer to (PIL 15-06).
12. Measure the valve recession with a suitable DTI (Dial Test Indicator). Clean the carbon deposits from a small area of the valve heads for location of the DTI probe. If the valve recession is outside the serviceable limits, it is advisable to obtain a new or reconditioned cylinder head assembly, refer to Technical Data (PIL 15-06).
13. To aid removal and replacement, use a wooden valve stand to retain the valves after removal. Add labels to make sure that the valves are correctly replaced.

Figure 163. Valve Stand

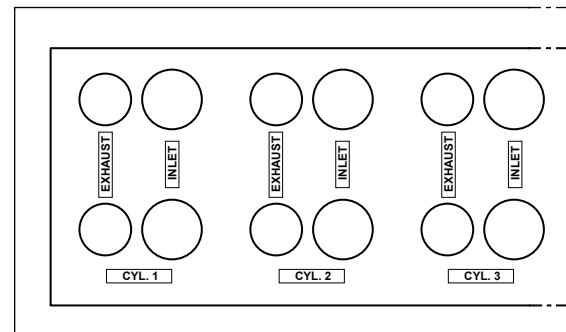

Remove

1. Use a spring compressor tool to compress each valve spring and remove the collets. Make sure that the springs are compressed squarely.

Figure 164.

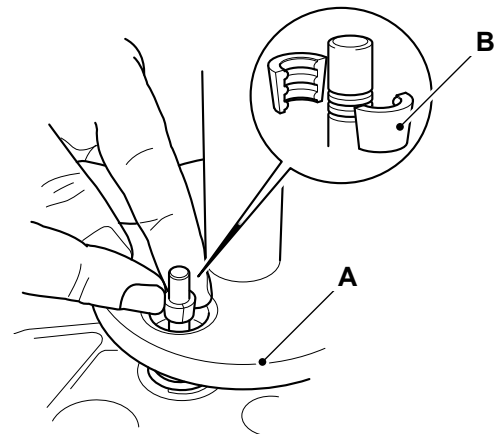

- A** Spring compressor tool
B Collets

2. Remove the spring compressor tool and lift off the retainer and valve spring.

Figure 165.

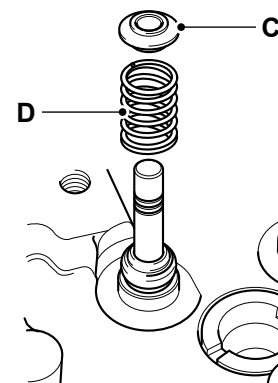

- C** Retainer
D Valve spring

3. Turn the cylinder head on its side and withdraw the inlet valves and exhaust valves as shown.

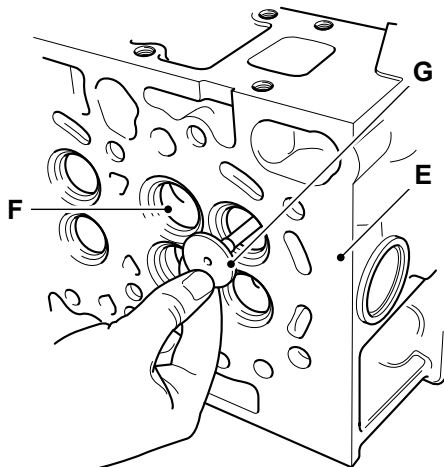
Figure 166.

E Cylinder head
F Inlet valves
G Exhaust valves

4. When removing, note the respective position of each valve. Use a suitable valve stand to keep the valves together and identify them with their respective cylinder. Note: The exhaust valves have smaller diameter heads.
5. Remove the valve stem seals. Discard the seals.

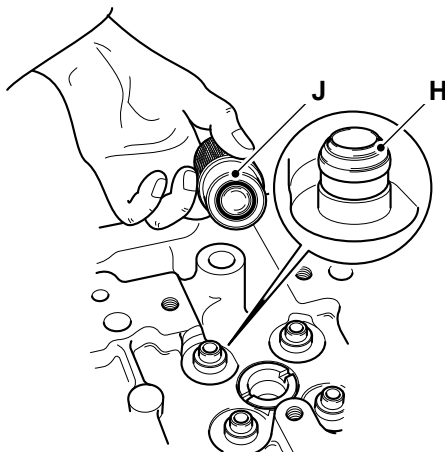
Figure 167.

H Valve stem seals
J Punch tool

Inspection

1. Carefully clean the carbon deposits from the valves, take care not to damage the valve seats.
2. Check that the valves and valve seats are not cracked, burnt or damaged.
3. Check the valve stems and valve guides for wear, refer to Technical Data (PIL 15-30).

If there is evidence of wear or damage to the valves, guides or seats, it is advisable to obtain a new or reconditioned cylinder head assembly.

Before Installation

1. Position the cylinder head upside down in a suitable jig or fixture.
2. Make sure that all items are clean and free from damage and corrosion.
3. Install the injectors into the cylinder head to do a trial check of the nozzle protrusion. Note the relative positions for the injectors, and then remove the injectors for installation at a later stage.

Installation

1. The installation procedure is the opposite of the removal procedure. Additionally do the following steps.
2. Install the new valve stem seals as shown. Use the installation tool to avoid damaging the seals. Pre-assemble the seal into the tool. Locate the tool over the valve guide and gently press the seal into place. Lubricate the seal with P80 fluid.
[Special Tool: Valve Stem Seal Installation Tool \(444/448/762 Engine\) \(Qty.: 1\)](#)
3. With the cylinder head on its side, insert the inlet valves and exhaust valves as shown. Make sure that the valves are installed in the correct positions. Lubricate the valve stems with clean engine oil before assembly. Carefully push the end of the valve stem through the stem seals.
4. Install the valve springs on to the valve stems, together with a retainer. Use the spring compressor tool to compress each valve spring and insert the collets. Make sure that the collets are correctly seated in the valve stem grooves, before you remove the spring compressor tool.

After Installation

1. Tap the valve stems in turn using a rubber mallet top fully seat the valves.

Check (Condition)

1. Check the bearing shell surfaces for signs of damage and excessive wear.
2. Measure the crank pin diameters to confirm they are within service limits, refer to Technical Data (PIL 15-33).
3. Renew any parts that are worn or not within the specified tolerances.

Remove and Install

Special Tools

Description	Part No.	Qty.
Torque Wrench (10-100Nm)	993/70111	1

Before Removal

1. This procedure requires service parts. Make sure you have obtained the correct service parts before you start. Refer to Parts Catalogue.
2. Make sure that the engine is safe to work on. If the engine has been running, let it cool before you start the service work.
3. Get access to the engine.
4. Disconnect and remove the fuel pipes from the injectors. Refer to (PIL 18-96).
5. Remove the rocker cover. Refer to (PIL 15-42).
6. Remove the fuel injectors. Refer to (PIL 18-18).
7. Drain the oil from the engine. Refer to (PIL 15-21).
8. Remove the oil sump. Refer to (PIL 15-45).
9. Position the engine upside down in a suitable jig or fixture, supported at the front of the crankcase.

The connecting rod and the big-end bearing cap have been fracture split and must be kept together as a set. Care must be taken to avoid contamination and or damage to the fracture split surfaces.

Remove

1. It is recommended that the big-end bearing caps are removed in pairs, cylinders 1 and 4 and cylinders 2 and 3. Rotate the crankshaft so that the big-end bearing caps on cylinders 2 and 3 are positioned as shown.
2. Remove the bolts and lift off the big-end bearing caps from the connecting rods. The bolts must not be re-used, discard the bolts.

Figure 168.

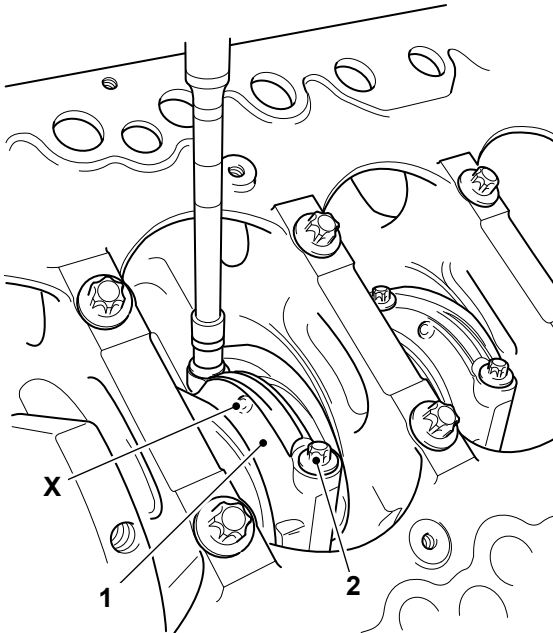

- 1 Big-end bearing caps
- 2 Big-end bearing cap bolts
- X Cast notch

2.1. Make sure that the tool is kept in inline with the bolt to avoid damaging the screw thread.

3. Lift out the bearing shells from the bearing caps. Carefully rotate the crank to disengage from the connecting rods and get access to the upper bearing shells. Lift out the upper bearing shells. It is recommended that the bearing shells are renewed. If they are to be reused, label the bearing shells to make sure that they are installed in their original positions on assembly.

Figure 169.

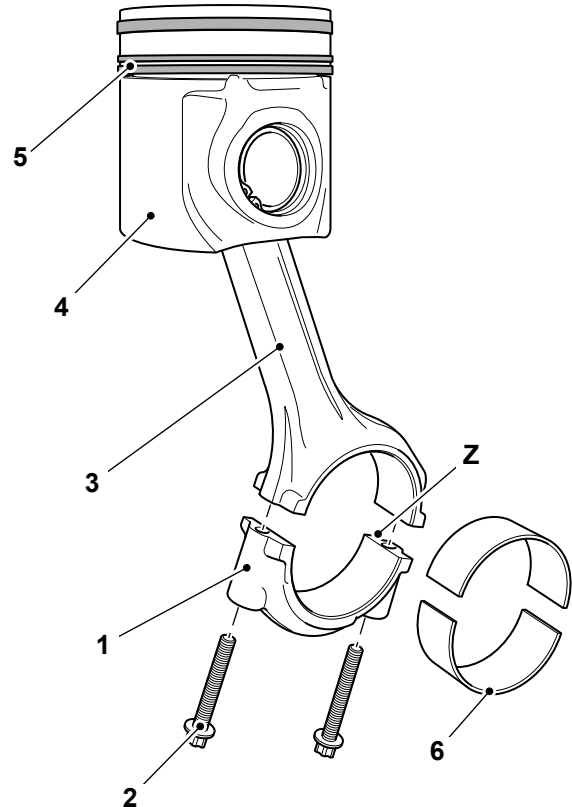

- 1 Big-end bearing cap
- 2 Bolts
- 3 Connecting rod
- 4 Piston
- 5 Piston rings
- 6 Big end bearing shells
- Z Fracture split surfaces

4. Carefully rotate the crankshaft to position the big-end bearing caps of cylinders 1 and 4. Make sure that the crank does not foul the connecting rods of cylinders 2 and 3. Remove the bearing caps and bearing shells as described in previous steps.
5. Inspect the big-end bearings for signs of damage and excessive wear. Refer to Check Condition (PIL 15-12).

Install

1. The installation procedure is the opposite of the removal procedure. Additionally do the following steps.
2. Make sure that all items are clean and free from damage and corrosion.
3. Install the upper bearing shell to the connecting rod. Lubricate the bearing shell with clean engine oil.

4. Install the lower bearing shell to the big-end bearing cap. Lubricate the bearing shell with clean engine oil. Install the big-end bearing cap to the connecting rod. Make sure that the cast notch on the bearing cap faces to the front of the engine. Use compressed air to clean the fracture surfaces before assembly.
5. Install new fixing bolts. Tighten the new bolts in three stages to the correct torque value.

Special Tool: Torque Wrench (10-100Nm) (Qty.: 1)

Figure 170.

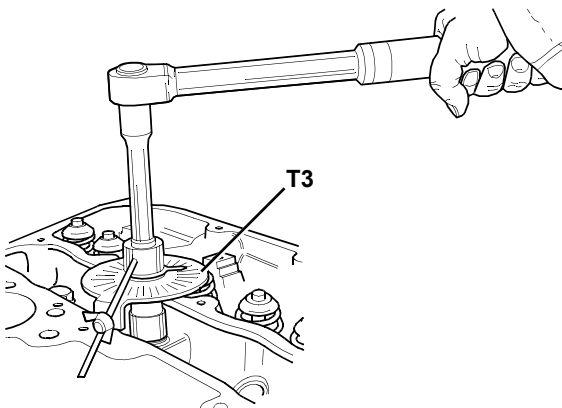

T3 Angle gauge (obtain locally)

- 5.1. Make sure that the tool is kept in inline with the bolt to avoid damaging the screw thread.
6. The bolts are tightened using a torque and angle method. Refer to Fasteners and Fixings, General, Introduction (PIL 72-00).

Figure 171.

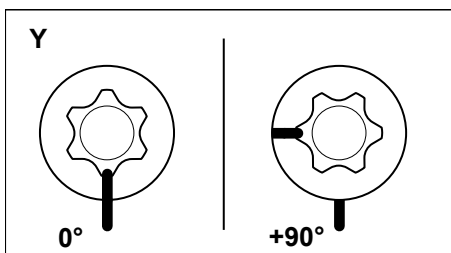

After Installation

1. Carry out the procedures listed in Before Removal in reverse order.

Table 74.

Item	Torque Value
2 - 1st Stage	35N·m
2 - 2nd Stage	65N·m
2 - Final Stage	90°

Technical Data

Table 75.

Engine	444 - SE Engine	444 - excluding SE engine	448, 672
Gudgeon pin bore diameter			
- min.	4.0008mm	40.01mm	42.008mm
- max.	40.013mm	40.015mm	42.013mm
Piston ring clearance			
- Top ring	Half keystone ring	Full keystone ring	Full keystone ring
- Middle ring	0.11–0.07mm	0.125–0.08mm	0.125–0.08mm
- Bottom (oil) ring	0.09–0.05mm	0.09–0.05mm	0.09–0.05mm
Piston ring gap			
- Top ring	0.3–0.5mm	0.3–0.4mm	0.3–0.4mm
- Middle ring	0.55–0.8mm	0.55–0.8mm	0.55–0.8mm
- Bottom (oil) ring	0.25–0.5mm	0.25–0.5mm	0.25–0.5mm
Piston height above crankcase (cold)	0.0375–0.3385mm	0.00025–0.36825mm ⁽¹⁾	0.00025–0.36825mm ⁽¹⁾
Piston groove width			
- Top ring	3.108–3.133mm	3.114–3.134mm	3.114–3.134mm
- Middle ring	2.56–2.58mm	2.575–2.595mm	2.575–2.595mm
- Bottom (oil) ring	4.04–4.06mm	4.04–4.06mm	4.04–4.06mm
Piston skirt	-	102.853–102.871mm	105.851–105.869mm
Piston pin	-	39.994–40mm	41.994–42mm

(1) Nominal measurement is 0.03325mm

Buy Now



Our support email:

ebooklibonline@outlook.com