

100 ENGINE SUSPENSION

Pos.	Part No.	Description	Dimension	Quantity	Conditions
1	00 0211 573 0	HEXAGON HEAD BOLT	M18-100	2	
1	00 0212 191 0	CONTACT WASHER	A20	2	
1	00 0242 848 0	HEXAGONAL NUT	M18	2	
2	00 0796 231 0	BUSHING	D42D20.5X62	2	
3	00 0799 395 3	ENGINE MOUNTING	C13 T3	1	
4	00 0237 458 0	HEXAGON HEAD BOLT	M12X20	4	
5	00 0239 389 0	CONTACT WASHER	A12	7	
6	00 0237 461 0	HEXAGON HEAD BOLT	M12X30	3	
7	00 0799 298 0	SUPPORT	6X171,6X271,6	1	
8	00 0215 631 0	HEXAGON HEAD BOLT	3/4-10UNC-2AX4 1/2	4	
9	00 0212 191 0	CONTACT WASHER	A20	4	
10	00 0796 231 0	BUSHING	D42D20.5X62	4	
11	00 0239 389 0	CONTACT WASHER	A12	1	
12	00 0211 465 0	HEX.HEAD BOLT	1/2-13UNC-2AX1 1/2	1	
13	00 0236 230 0	HEXAGON HEAD BOLT	M16X35	6	
14	00 0239 391 0	CONTACT WASHER	A16	8	
15	00 0239 415 0	HEXAGON HEAD BOLT	M16X85	2	
16	00 0796 273 0	BUSHING	D32/D18X50	2	

E0175 0125A100A 1

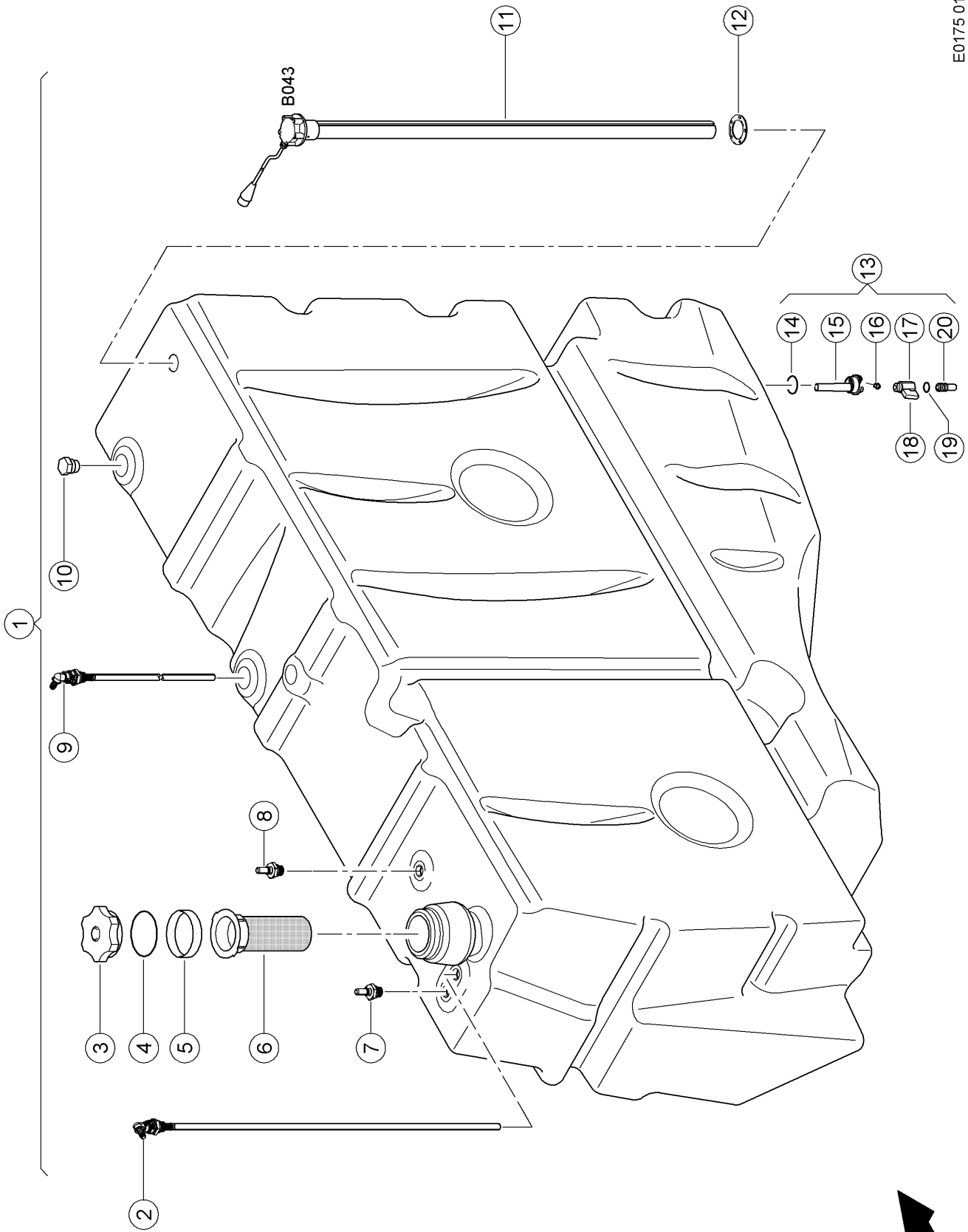

100 FUEL TANK 1)

Pos.	Part No.	Description	Dimension	Quantity	Conditions
1	00 0506 711 1	FUEL TANK	800 LTR OHNE Z-TANK	1	2)
1	00 0506 391 0	FUEL TANK	800LTR. FUER Z-TANK	1	3)
1	00 0506 392 0	FUEL TANK	600LTR. FUER Z-TANK	1	4)
2	00 0783 661 0	RETURN PIPE	KURZ FUER Z-TANK 600+800	1	5)
3	00 0217 508 0	CAP	DV 80 GL OHNE LÜFTUNG	1	
3	00 0177 621 0	CAP	D80 BELUEFTET, ABSCHLIES	1	6)
4	00 0211 701 0	O-RING	91,67X3,53-N	1	
5	00 0038 915 0	SOCKET	SV 80 B/40	1	
6	00 0736 238 0	TANK FILTER		1	
7	00 0783 647 1	ADAPTER		1	5)
8	00 0794 417 2	VENTILATION		1	
9	00 0783 660 0	RETURN PIPE	LANG FUER 800LTR. TANK	1	7)
9	00 0783 659 0	RETURN PIPE	MITTEL FUER 600LTR TANK	1	8)
10	00 0783 648 2	BLIND PLUG		1	5)
10	00 0783 648 2	BLIND PLUG		3	9)
11	00 0016 596 3	LEVEL INDICATOR	L=1320MM	1	10)
11	00 0016 597 1	LEVEL INDICATOR	1065MM / 99MM	1	11)
12	00 0794 993 0	GASKET	VORRATSGEBER	1	
13	00 0794 414 1	CONNECTION	MIT W.ABLAS ; KUGELH. ;	1	12)
14	00 0217 459 1	O-RING	27X4,0 -N	1	
15	00 0783 643 1	PLUG	WASSER + G3/8"	1	
16	00 0687 625 0	HEXAGON HEAD SCREW	M 8X 17	1	
17	00 0783 652 0	BALL-TYPE TAP	DN8-I-G3/8XA-G3/8	1	
18	00 0783 658 0	ANTI-ROTAT. LOCK	FUER 3/8" KUGELHAHN	1	
19	00 0216 366 0	O-RING	10,50X1,5 NBR80	1	
20	00 0783 644 1	ADAPTOR	G3/8" - 1/2" SAE J 20441		

1) Equipment

MD_P14_0080	Fuel tank 800 litres
MD_P14_0095	Fuel tank 950 litres
MD_P14_0115	Fuel tank 1150 litres

2) Equipment**Remarks**

MD_P14_0080	Fuel tank 800 litres with Item 3 - 6, 8 - 12
-------------	---

3) Equipment**Remarks**

MD_P14_0115	Fuel tank 1150 litres with Item 2 - 12
-------------	---

4) Equipment**Remarks**

MD_P14_0095	Fuel tank 950 litres with Item 2 - 12
-------------	--

5) Equipment

MD_P14_0095	Fuel tank 950 litres
MD_P14_0115	Fuel tank 1150 litres

6) Remarks

LOCKING

7) Equipment

MD_P14_0080	Fuel tank 800 litres
MD_P14_0115	Fuel tank 1150 litres

100 FUEL TANK 1)

8) Equipment	MD_P14_0095	Fuel tank 950 litres
---------------------	-------------	----------------------

9) Equipment	MD_P14_0080	Fuel tank 800 litres
---------------------	-------------	----------------------

10) Equipment	MD_P14_0080	Fuel tank 800 litres
CCN	MD_P14_0115	Fuel tank 1150 litres
	CCN-B043	fuel level sensor

11) Equipment	MD_P14_0095	Fuel tank 950 litres
CCN	CCN-B043	fuel level sensor

12) Remarks		with item 14 - 20
--------------------	--	-------------------

E0175 0125A100A 2

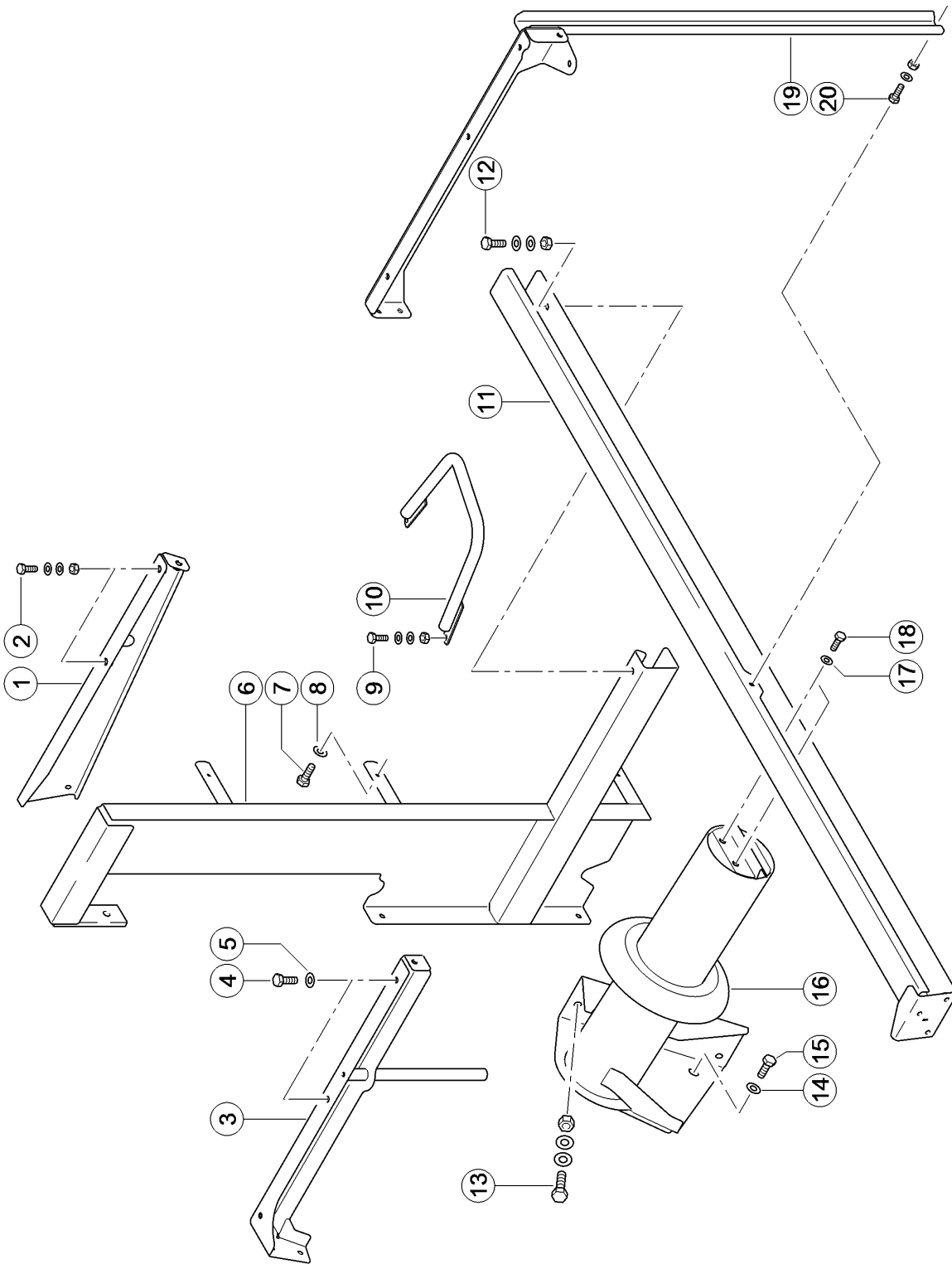

100 FUEL TANK 1)

Pos.	Part No.	Description	Dimension	Quantity	Conditions
1	00 0794 841 3	FASTENER	1420	1	
2	00 0237 370 0	HEXAGON HEAD BOLT	M8X30	2	
2	00 0239 387 0	CONTACT WASHER	A8-8,2X18X1,4	4	
2	00 0236 170 0	HEXAGONAL NUT	M8	2	
3	00 0794 939 1	SUPPORT	688,5X164X109,8	1	2)
3	00 0794 936 2	SUPPORT	1420 / 600LTR.	1	3)
4	00 0237 453 0	HEXAGON HEAD BOLT	M10X30	2	
5	00 0239 388 0	CONTACT WASHER	A10-10,2X22,25X1,6	2	
6	00 0794 938 3	SUPPORT	1420	1	
7	00 0237 453 0	HEXAGON HEAD BOLT	M10X30	3	
8	00 0239 388 0	CONTACT WASHER	A10-10,2X22,25X1,6	3	
9	00 0237 453 0	HEXAGON HEAD BOLT	M10X30	2	
9	00 0239 388 0	CONTACT WASHER	A10-10,2X22,25X1,6	4	
9	00 0236 171 0	HEXAGONAL NUT	M10	2	
10	00 0782 676 0	REINFORCING PLATE		1	
11	00 0794 855 1	SUPPORT		1	
12	00 0237 453 0	HEXAGON HEAD BOLT	M10X30	1	
12	00 0239 388 0	CONTACT WASHER	A10-10,2X22,25X1,6	2	
12	00 0236 171 0	HEXAGONAL NUT	M10	1	
13	00 0237 461 0	HEXAGON HEAD BOLT	M12X30	4	
13	00 0239 389 0	CONTACT WASHER	A12	8	
13	00 0236 172 0	HEXAGONAL NUT	M12	4	
14	00 0239 388 0	CONTACT WASHER	A10-10,2X22,25X1,6	1	
15	00 0237 453 0	HEXAGON HEAD BOLT	M10X30	1	
16	00 0794 935 2	MAIN FRAME	1420	1	
17	00 0239 387 0	CONTACT WASHER	A8-8,2X18X1,4	2	
18	00 0237 439 0	HEXAGON HEAD BOLT	M8X16	2	
19	00 0794 937 2	SUPPORT	1420	1	
20	00 0237 439 0	HEXAGON HEAD BOLT	M8X16	3	
20	00 0239 387 0	CONTACT WASHER	A8-8,2X18X1,4	4	
20	00 0236 170 0	HEXAGONAL NUT	M8	1	

1) Equipment

MD_P14_0080	Fuel tank 800 litres
MD_P14_0095	Fuel tank 950 litres
MD_P14_0115	Fuel tank 1150 litres

2) Equipment

MD_P14_0080	Fuel tank 800 litres
MD_P14_0115	Fuel tank 1150 litres

3) Equipment

MD_P14_0095	Fuel tank 950 litres
-------------	----------------------

E0175 0125A110A 1

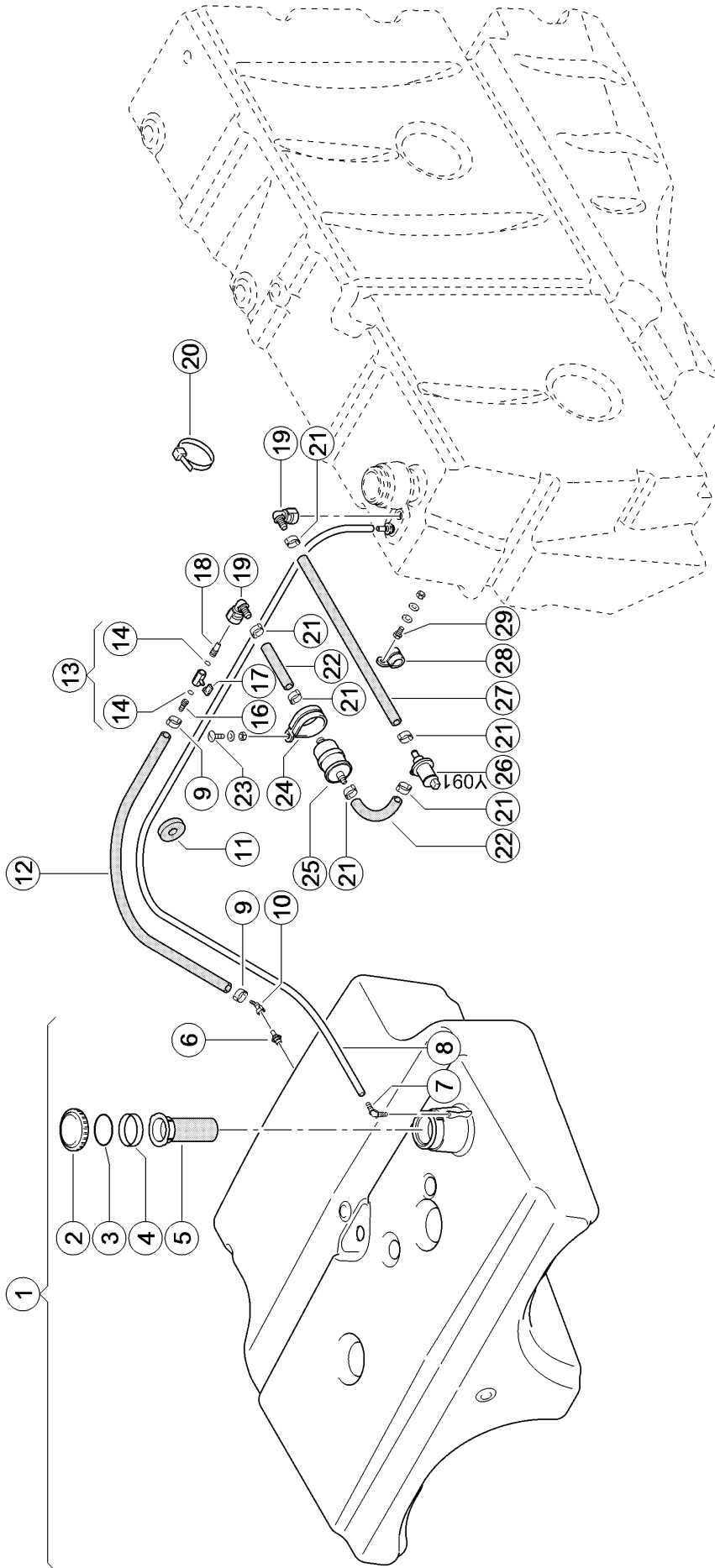

110 ADITIONAL FUEL TANK 1)

Pos.	Part No.	Description	Dimension	Quantity	Conditions
1	00 0794 919 0	ADDITIONAL TANK	350 LITER	1	
2	00 0217 508 0	CAP	DV 80 GL OHNE LÜFTUNG	1	
3	00 0211 701 0	O-RING	91,67X3,53-N	1	
4	00 0038 915 0	SOCKET	SV 80 B/40	1	
5	00 0736 238 0	TANK FILTER		1	
6	00 0783 647 1	ADAPTER		1	
7	00 0217 502 0	SCREWING	WN 6 X 90 GRAD	1	
8	00 0202 240 0	HOSE	A 6X10	2	
8	00 0217 507 0	PIPE BRACKET	NW 7,5	4	
9	00 0238 269 0	2-EAR-CLAMP	15-18	2	
10	00 0217 500 0	CONNECTOR	NQS 1/2" -10 X 45 GRAD	1	
11	00 0215 409 0	GROMMET	C 10-18X30X1,5	2	
12	00 0217 524 0	HOSE	20M ROLLE-B 11X3,5	1	
13	00 0794 419 0	BALL-TYPE TAP	F. Z-TANK 350LTR.	1	2)
14	00 0216 366 0	O-RING	10,50X1,5 NBR80	2	
16	00 0783 650 1	HOSE SUPPORT		1	
17	00 0783 658 0	ANTI-ROTAT. LOCK	FUER 3/8" KUGELHAHN	1	
18	00 0783 644 1	ADAPTOR	G3/8"- 1/2" SAE J 20441		
19	00 0798 863 0	CONNECTOR	NORMAQUICK S NW 1/2"-10-	2	
20	00 0237 871 0	CABLE TIE	4,8X188X1,3	2	
21	00 0238 269 0	2-EAR-CLAMP	15-18	6	
22	00 0217 524 0	HOSE	20M ROLLE-B 11X3,5	0	
23	00 0610 099 1	COACH BOLT	M 8X 25	1	
23	00 0239 387 0	CONTACT WASHER	A8-8,2X18X1,4	1	
23	00 0236 170 0	HEXAGONAL NUT	M8	1	
24	00 0214 045 0	PIPE CLAMP	D1-47X20	1	
25	00 0783 662 0	CHANGEABLE FILTER		1	
26	00 0755 465 0	SHUT OFF VALVE		1	3)
27	00 0217 524 0	HOSE	20M ROLLE-B 11X3,5	0	
28	00 0215 612 0	PIPE CLAMP	D1-17X20	1	
29	00 0237 439 0	HEXAGON HEAD BOLT	M8X16	1	
29	00 0239 387 0	CONTACT WASHER	A8-8,2X18X1,4	2	
29	00 0236 170 0	HEXAGONAL NUT	M8	1	

1) EquipmentMD_P14_0095
MD_P14_0115Fuel tank 950 litres
Fuel tank 1150 litres**2) Remarks**

with item 14 - 18

3) CCN

CCN-Y091

additional fuel tank solenoid coil

E0175 0125A140A 1

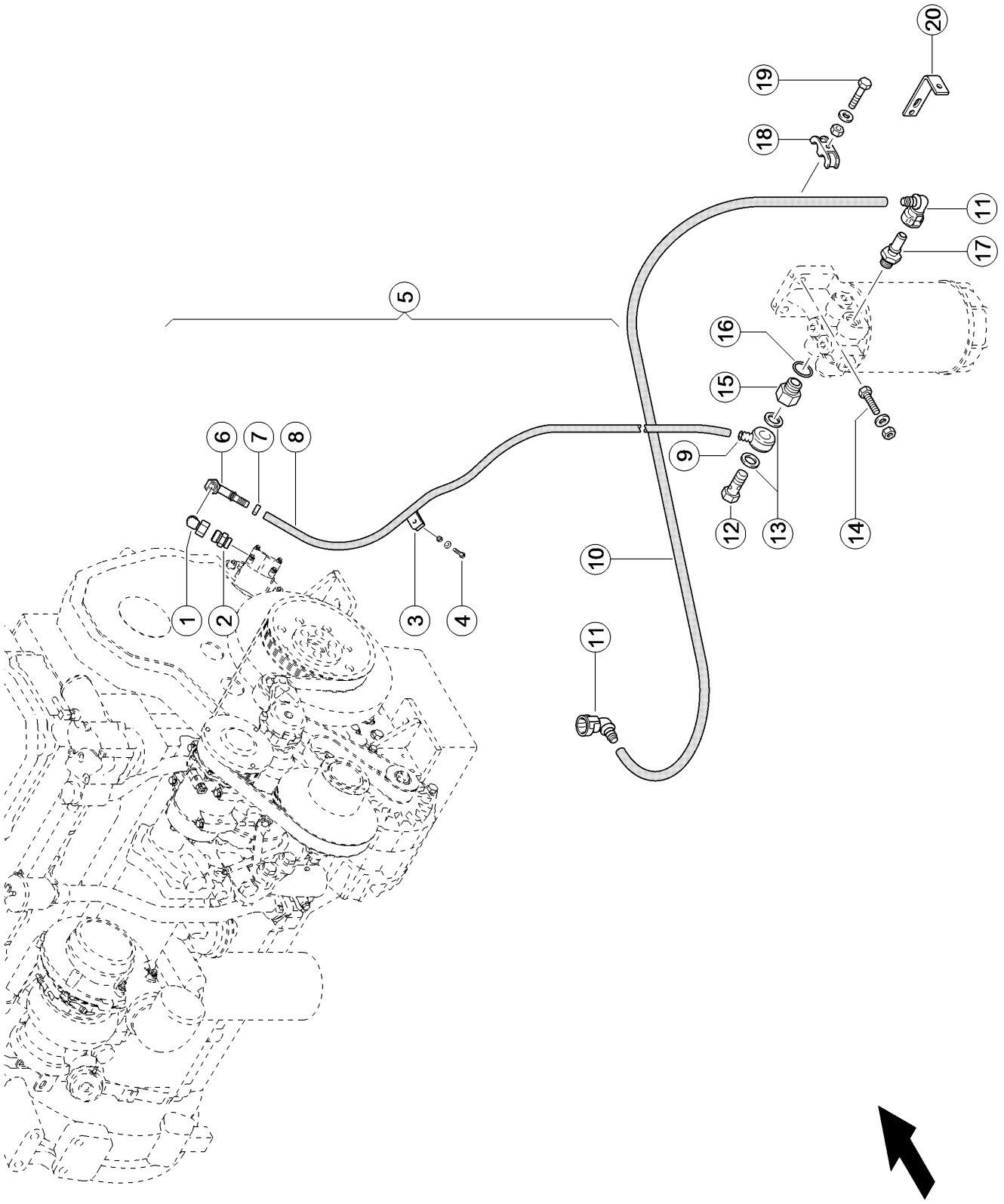

140 FUEL PIPES

Pos.	Part No.	Description	Dimension	Quantity	Conditions
1	00 0249 836 0	ANGULAR MALE CONNECTOR	SWOE-L15	1	
2	00 0239 037 0	TIE-IN UNION	SDS-L15X3/4-16UNF-2A-TYP	1	
3	00 0715 242 0	CLAMP	A 15	1	
4	00 0242 442 0	HEXAGON HEAD BOLT	M 6X30	1	
4	00 0239 386 0	CONTACT WASHER	A 6	1	
4	00 0236 169 0	HEXAGONAL NUT	M6	1	
5	00 0798 284 1	FUEL PIPE		1	1)
6	00 0796 220 1	CONNECTION	SWE90-L15-12 (N90-M22X1, 15-18	1	2)
7	00 0238 269 0	2-EAR-CLAMP	15 X1,5X10000	1	
8	00 0136 591 0	PLASTIC TUBE	R16-12	1	
9	00 0216 458 0	CONNECTION	TANK-FILTER	1	3)
10	00 0799 121 1	FUEL PIPE		1	
11	00 0798 863 0	CONNECTOR	NORMAQUICK S NW 1/2"-10- 12 - M16X1,5 (12-3	2	
12	00 0096 030 0	HOLLOW SCREW	ZULÄS D 16X22	1	
13	00 0216 465 0	SEALING RING	M8X25	2	
14	00 0237 442 0	HEXAGON HEAD BOLT	B 8 -8.2X22X1,9	2	
14	00 0239 393 1	CONTACT WASHER	M8	2	
14	00 0236 170 0	HEXAGONAL NUT	M22X1.5/M16X1.5	1	4)
15	00 0545 906 0	SCREW UNION	19,3 X2,4 -N	1	4)
16	00 0238 451 0	O-RING	DN 12 - F-M22X1,5	1	4)
17	00 0798 652 1	ADAPTER	M16X1,5 / 1/2" SAE J 204	1	5)
17	00 0798 664 0	ADAPTER		1	
18	00 0715 242 0	CLAMP	A 15	3	
18	00 0216 117 0	CLAMP	A 10	1	
19	00 0235 505 0	HEXAGON HEAD BOLT	M06X30	3	
19	00 0238 094 0	HEXAGON HEAD BOLT	M06X25	1	
19	00 0239 386 0	CONTACT WASHER	A 6	5	
19	00 0236 169 0	HEXAGONAL NUT	M6	5	
20	00 0713 845 1	SUPPORT ANGLE	25X5X130	1	

1)	Remarks	with Item 6 - 9
2)	machine no.	+ up to C5500883
3)	Remarks	with Item 11
4)	Equipment	MD_P06_0010 Additional fuel filter
5)	Equipment	MD_P06_0020 Fuel pre-filter

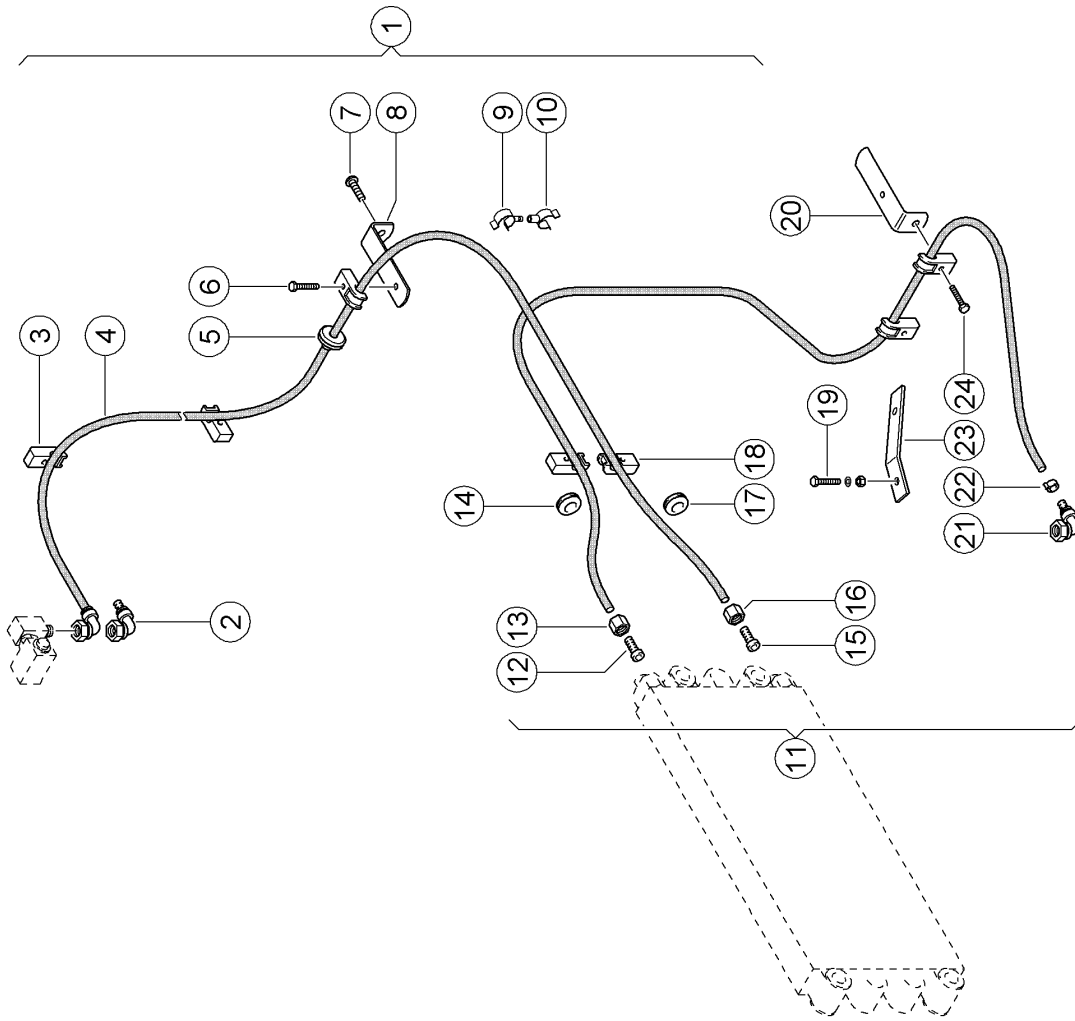

140 FUEL PIPES

Pos.	Part No.	Description	Dimension	Quantity	Conditions
1	00 0799 908 2	FUEL PIPE	KUEHLER-TANK LG 2400 MM	1	1)
2	00 0798 863 0	CONNECTOR	NORMAQUICK S NW 1/2"-10-	1	
3	00 0216 117 0	CLAMP	A 10	4	
4	00 0136 559 0	TUBE	12,5X1,25X10000	1	
5	00 0735 998 0	GROMMET	C 6-12X24X1,5	1	
6	00 0238 094 0	HEXAGON HEAD BOLT	M06X25	2	
7	00 0235 341 0	COACH BOLT	M 6X30	2	
8	00 0659 359 1	SCREW-ON ANGLE	20X3X79	1	
9	00 0796 374 0	PIPE BRACKET	D 11	1	
10	00 0796 375 0	PIPE BRACKET	D 11	1	
11	00 0798 242 1	FUEL PIPE		1	2)
12	00 0239 304 0	CONNECTION	D16X1,5-8	1	
13	00 0216 006 0	UNION NUT	BLL10	1	
14	00 0735 998 0	GROMMET	C 6-12X24X1,5	1	
15	00 0215 167 0	CONNECTION	D16X1,5-10	1	
16	00 0216 006 0	UNION NUT	BLL10	1	
17	00 0238 250 0	GROMMET	A 24X30X3,5	1	
18	00 0216 117 0	CLAMP	A 10	6	
19	00 0242 442 0	HEXAGON HEAD BOLT	M 6X30	1	
19	00 0239 386 0	CONTACT WASHER	A 6	1	
19	00 0236 169 0	HEXAGONAL NUT	M6	1	
20	00 0351 033 1	ANGLE	30X5X205	1	
21	00 0353 723 1	CONNECTION	90°-11/16-16UN-2B	1	
22	00 0408 544 1	CLAMP	10,8-13,3 STEPLESS	1	
23	00 0726 276 0	SUPPORT	25X4X149	1	3)
24	00 0242 442 0	HEXAGON HEAD BOLT	M 6X30	5	
24	00 0233 259 0	HEXAGON HEAD BOLT	M08X20-MKL	1	

1) Remarks with Item 2,4,5,15 - 17

2) Remarks with Item 12 - 14, 21, 22

3) machine no. + up to C5500703

E0175 0125A160A 1

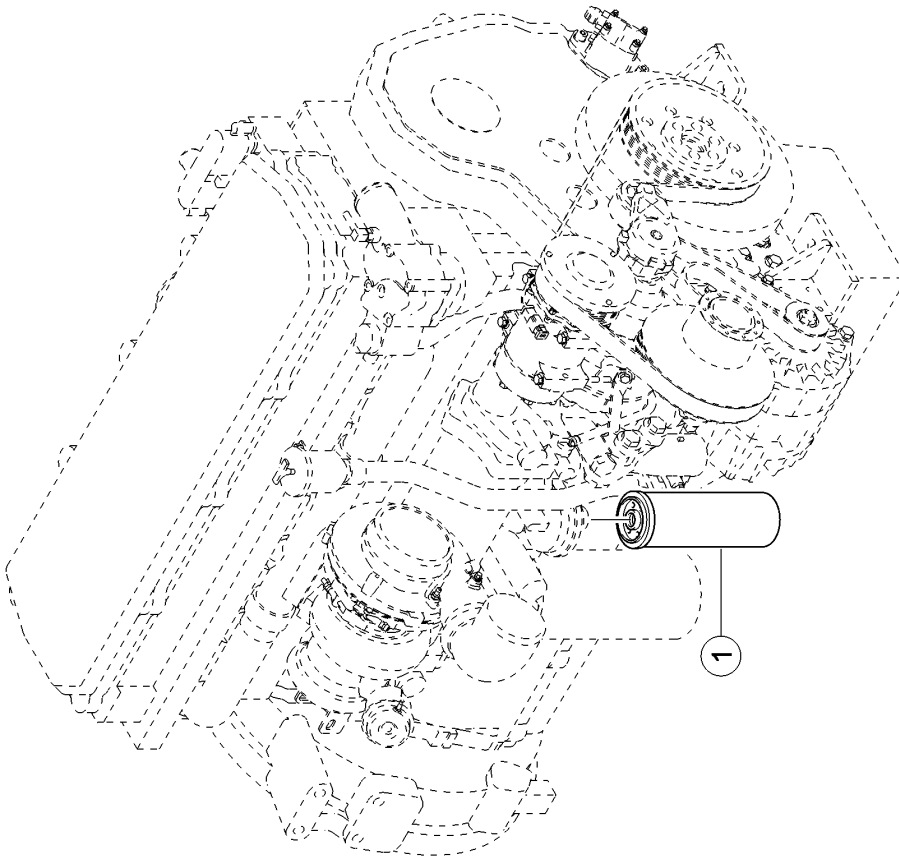
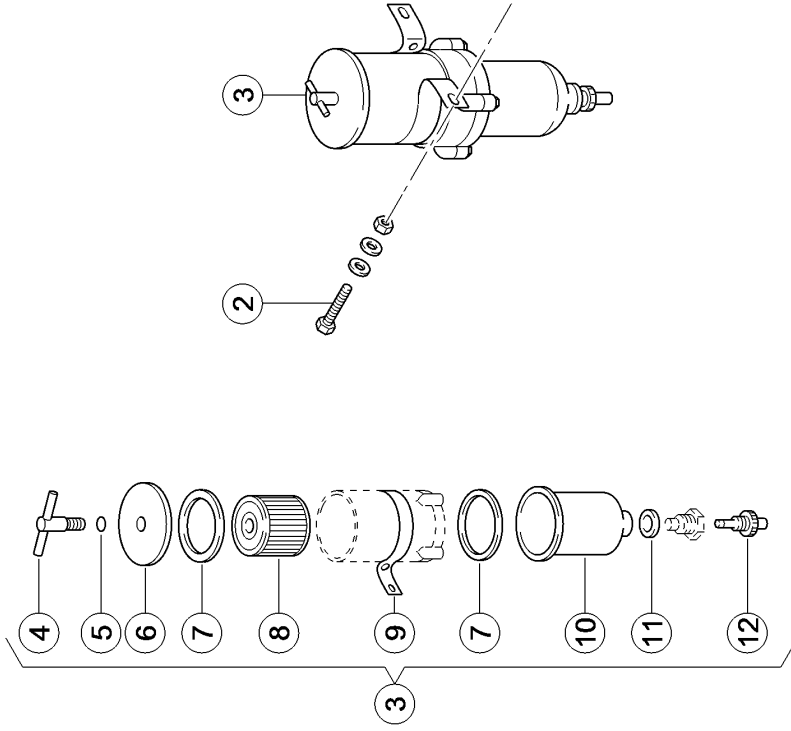

160 FUEL FILTER 1)

Pos.	Part No.	Description	Dimension	Quantity	Conditions
1	00 0363 204 1	FUEL FILTER		1	
2	00 0237 442 0	HEXAGON HEAD BOLT	M8X25	2	
2	00 0239 393 1	CONTACT WASHER	B 8 -8.2X22X1,9	4	
2	00 0236 170 0	HEXAGONAL NUT	M8	2	
3	00 0796 212 1	SEPARATOR		1	2)
4	00 0796 024 0	WING SCREW		1	
5	00 0211 091 2	O-RING	12 X 2 NBR 80	1	
6	00 0796 023 0	COVER		1	
7	00 0072 995 0	HOUSING GASKET		2	
8	00 0796 214 1	FILTER ELEMENT		1	3)
9	00 0067 328 1	SUPPORT		1	
10	00 0072 996 1	WATER CONTAINER		1	
11	00 0723 694 1	GASKET	RACOR 500/900 FG	1	
12	00 0796 022 0	DRAIN VALVE		1	

1) Equipment

MD_P06_0010

Additional fuel filter

2) Remarks

with Item 4 - 12

3) Remarks

with Item 5 + 7

Thank you so much for reading.
Please click the “Buy Now!”
button below to download the
complete manual.



After you pay.

You can download the most
perfect and complete manual in
the world immediately.

Our support email:

ebooklibonline@outlook.com