

CLAAS

1

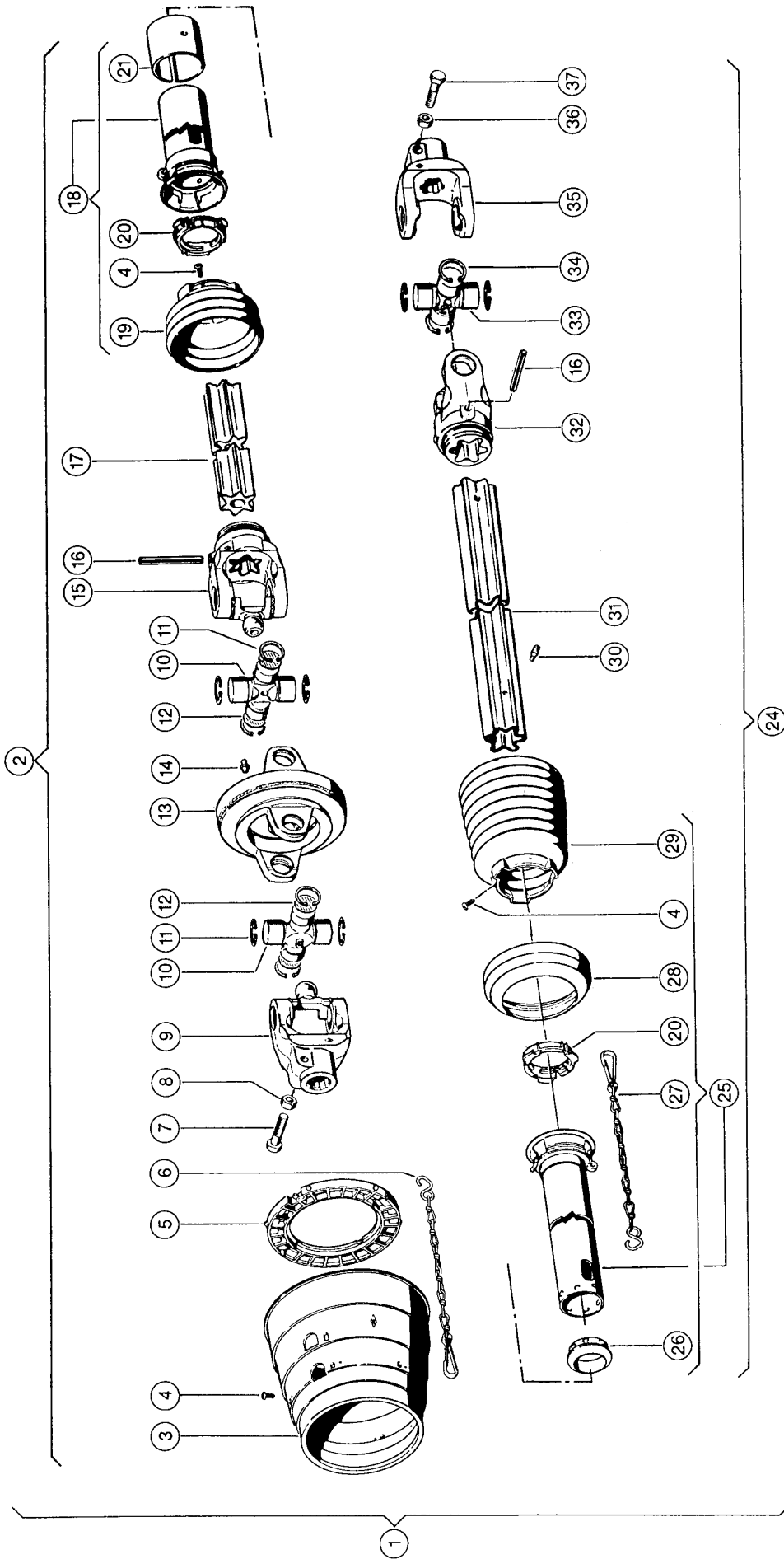

Quadrant 1150

110751

UNIVERSAL DRIVE SHAFT 1)

Pos.	Part No.	Description	Dimension	Quantity	Conditions
1	00 0830 002 2	DRIVE SHAFT ASSY.		1	2)
1	00 0830 003 2	DRIVE SHAFT ASSY.		1	3)
1	00 0831 125 0	DRIVE SHAFT ASSY.		1	4)
2	00 0830 058 0	DRIVE SHAFT HALF		1	2)
2	00 0830 050 0	DRIVE SHAFT HALF		1	3)
2	00 0831 130 0	DRIVE SHAFT HALF		1	4)
3	00 0821 097 0	PROTECT.FUNNEL		1	
4	00 0242 793 0	CYCL. PLATE SCREW	C4,2X 9,5	8	
5	00 0821 098 0	GLIDE RING		1	
6	00 0821 104 0	SUPPORTING CHAIN		1	
7	00 0235 559 0	HEXAGON HEAD BOLT	M12X75	1	
8	00 0238 234 0	LOCK NUT	M12	1	
9	00 0830 059 0	EXTENSION FORKE		1	2)
9	00 0830 054 0	EXTENSION FORKE		1	3)
9	00 0820 427 0	EXTENSION FORKE		1	4)
9	00 0830 732 0	EXTENSION FORKE		1	5)
9	00 0830 733 0	EXTENSION FORKE		1	6)
10	00 0820 421 0	CENTRE CROSS ASS.		2	7)
10	00 0211 636 0	GREASE NIPPLE	B M8X1-67,5°	2	
11	00 0242 908 0	CIRCLIP	32X1,2	4	
11	00 0972 503 0	CIRCLIP		4	
12	00 0921 267 0	WASHER		4	
13	00 0921 268 0	DOUBLE FORK		1	
14	00 0179 838 0	GREASE NIPPLE	A M8X1	1	
15	00 0830 057 0	FORK		1	
16	00 0244 581 2	SPRING PIN	10X 80	2	
17	00 0830 056 0	PROFILE SHAFT		1	8)
18	00 0830 052 0	PROTECTIVE TUBE		1	9)
19	00 0821 103 0	PROTECT.FUNNEL		1	
20	00 0920 671 0	GLIDE RING		2	
21	00 0817 787 0	COVERING		1	
24	00 0830 051 1	DRIVE SHAFT HALF		1	
25	00 0830 053 1	PROTECTIVE TUBE		1	10)
26	00 0817 323 0	GLIDE RING		1	
27	00 0972 297 0	SUPPORTING CHAIN		1	
28	00 0917 283 0	BACK-UP RING		1	
29	00 0813 018 1	PROTECT.FUNNEL		1	
30	00 0817 786 0	GREASE NIPPLE		1	
31	00 0830 055 0	PROFILE TUBE		1	8)
32	00 0940 254 0	FORK		1	
33	00 0941 651 0	CENTRE CROSS ASS.		1	11)
34	00 0242 908 0	CIRCLIP	32X1,2	4	
35	00 0941 650 0	EXTENSION FORKE		1	
36	00 0238 047 0	LOCK NUT	M16	1	
37	00 0235 593 0	HEXAGON HEAD BOLT	M16X90	1	

1) Remarks

Var.9033
1 3/8", 6-Teiliger Anschluss
Var.9034
1 3/8", 21-Teiliger Anschluss
Var.9680
1 3/8", 8-Teiliger Anschluss

2) Remarks

1 3/8", 6 piece

3) Remarks

1 3/8", 21 piece

UNIVERSAL DRIVE SHAFT 1)

4) Remarks	1 3/8", 8 piece
5) Remarks	1 3/4", 6 piece
6) Remarks	1 3/4", 20 piece
7) Remarks	with Item 11, 12
8) Remarks	965 long
9) Remarks	with Item 19 - 21
10) Remarks	with Item 26 - 29
11) Remarks	with Item 34

2

CLAAS

QUADRANT 1150

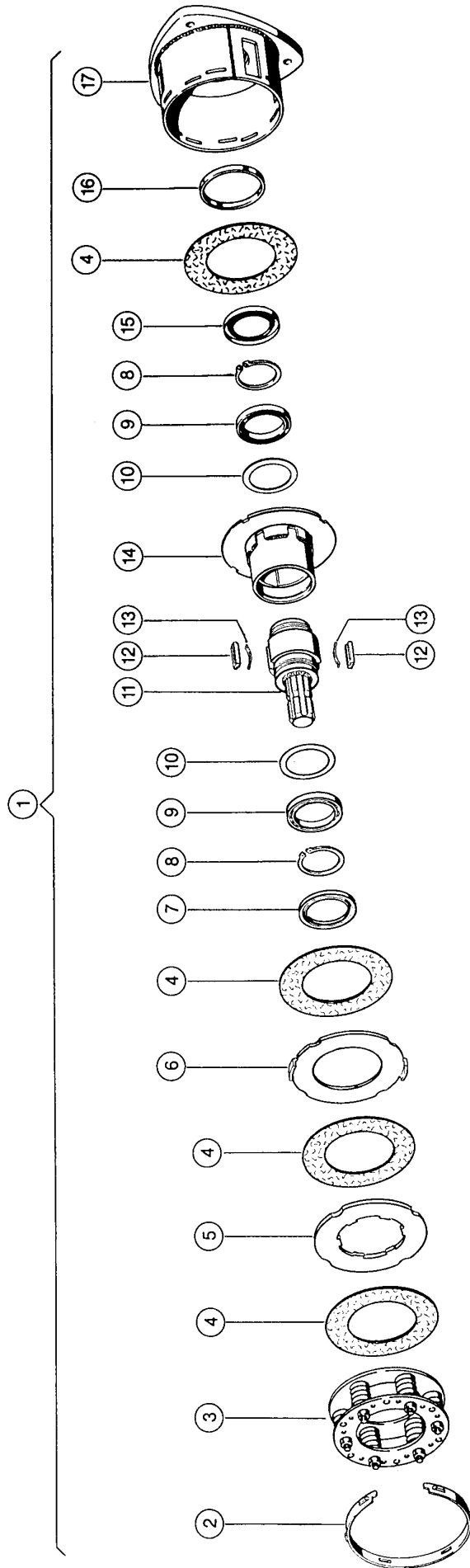

Quadrant 1150

110752

FRICITION AND OVERRUNNING CLUTCH

Pos.	Part No.	Description	Dimension	Quantity	Conditions
1	00 0831 548 0	FRICITION CLUTCH		1	
2	00 0941 099 0	ADJUSTING RING		1	
3	00 0830 296 0	SPRING KIT		1	1)
4	00 0941 104 1	FRICITION PLATE		4	
5	00 0941 106 0	DRIVE PLATE		1	
6	00 0941 107 0	DRIVE PLATE		1	
7	00 0921 795 0	SEALING RING		1	
8	00 0237 597 0	CIRCLIP	60X2	2	
9	00 0211 846 0	GRVD.BALL BEARING	61812	2	
10	00 0921 796 0	BACK-UP WASHER		2	
11	00 0817 305 0	HUB		1	
12	00 0814 228 0	STOP KEY		2	
13	00 0814 229 0	FLAT SPRING		2	
14	00 0921 794 1	COUPLER		1	
15	00 0238 277 2	SHAFT SEAL	AS 55X 80X 8	1	
16	00 0941 110 0	RING		1	
17	00 0814 766 1	CLUTCH HOUSING		1	

1) Remarks m = 1200 Nm

3

Quadrant 1150

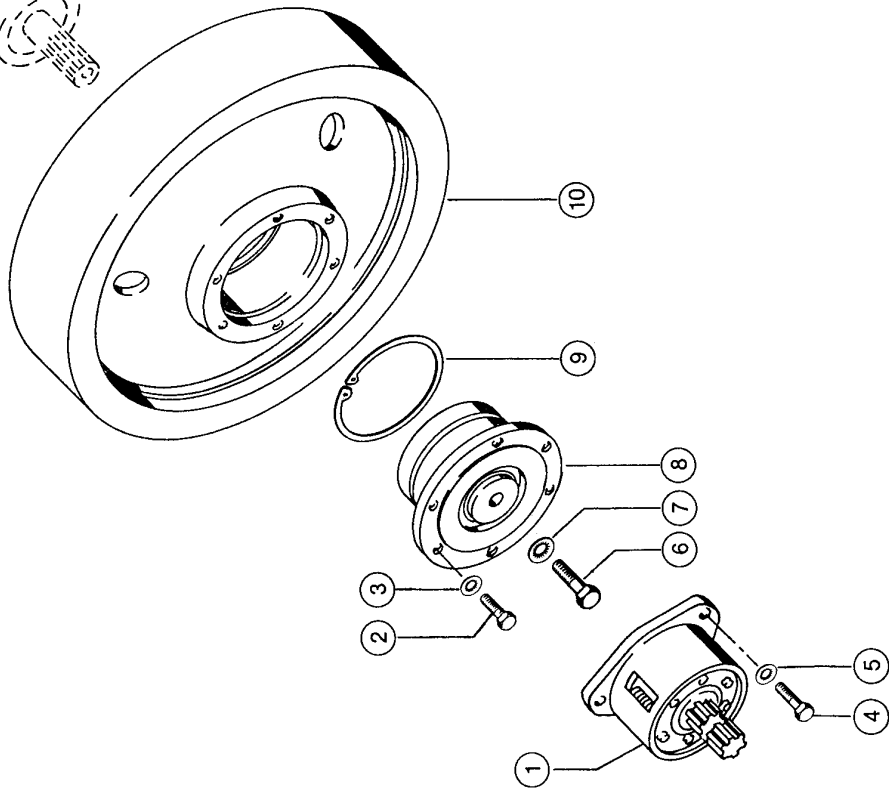
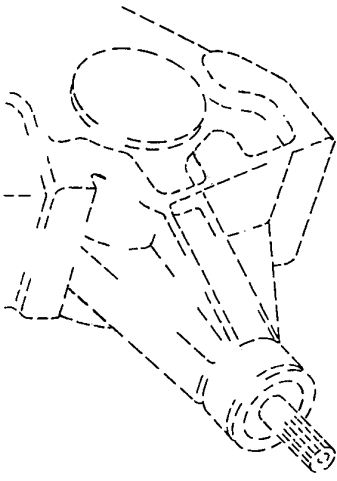

CLAAS

FLYWHEEL GP

Pos.	Part No.	Description	Dimension	Quantity	Conditions
1	00 0831 548 0	FRICITION CLUTCH		1	1)
2	00 0233 244 0	HEXAGON HEAD BOLT	M12X40-MKL	3	
3	00 0242 824 1	WASHER	12 -12,2X18,3X2,5	3	
4	00 0215 455 0	HEXAGON HEAD BOLT	M12X60-MKL	3	
5	00 0239 389 0	CONTACT WASHER	A12	3	
6	00 0233 334 0	HEXAGON HEAD SCREW	W.ERS.D.2333341	1	
7	00 0212 191 0	CONTACT WASHER	A20	1	
8	00 0831 233 1	CLUTCH		1	
9	00 0213 774 0	CIRCLIP	170X4	1	
10	00 0831 232 1	FLYWHEEL		1	

1) Remarks see illustration plate 2

4

Quadrant 1150

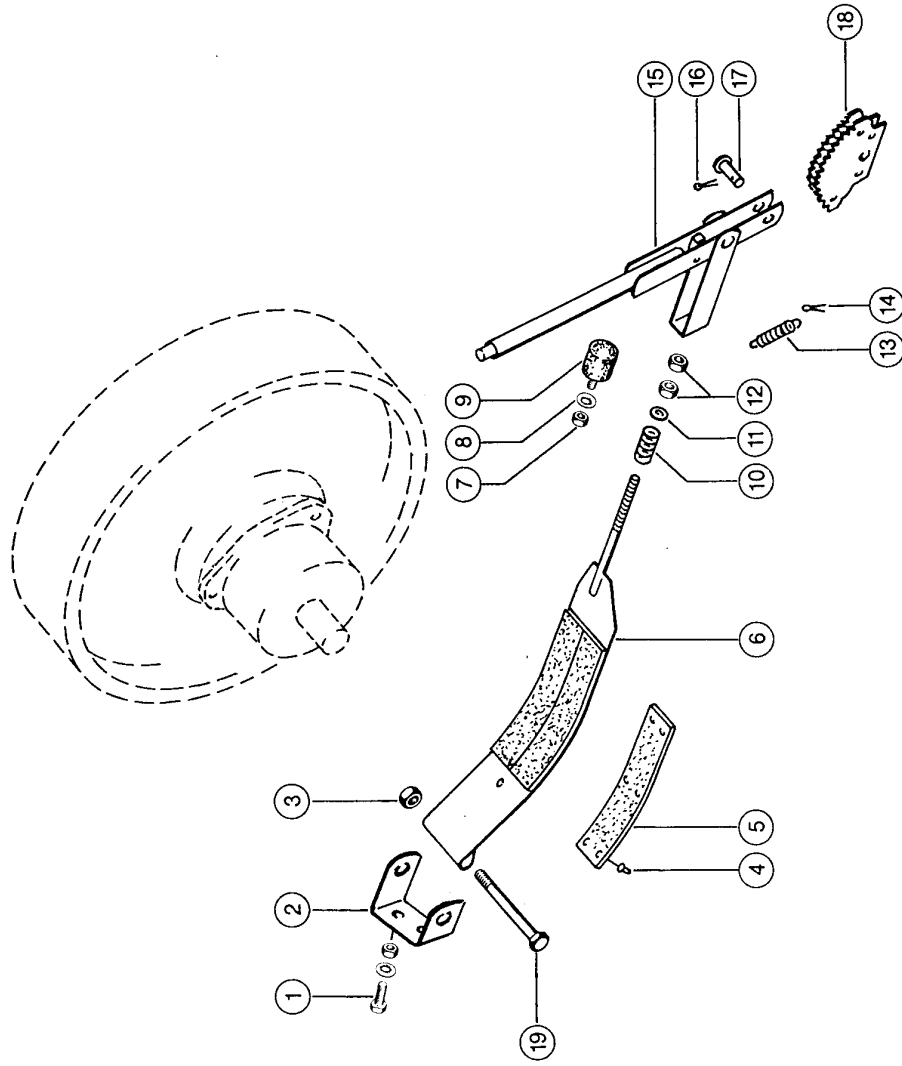

CLHHS

FLYWHEEL BRAKE

Pos.	Part No.	Description	Dimension	Quantity	Conditions
1	00 0236 200 0	HEXAGON HEAD BOLT	M8X20	2	
1	00 0236 170 0	HEXAGONAL NUT	M8	2	
1	00 0239 387 0	CONTACT WASHER	A8-8,2X18X1,4	2	
2	00 0830 119 1	SUPPORT	50X6X224,7	1	
3	00 0238 047 0	LOCK NUT	M16	1	
4	00 0235 768 0	RIVET	A4X15	12	
5	00 0830 148 0	BRAKE LINING		2	
6	00 0830 144 2	BRAKE BAND		1	
7	00 0238 132 0	LOCK NUT	M8	1	
8	00 0239 387 0	CONTACT WASHER	A8-8,2X18X1,4	1	
9	00 0980 464 0	BUFFER BUMPER	B40X35-M8X22,5	1	
10	00 0800 444 1	COMPRESS.SPRING	4,5 X 15 X 30	1	
11	00 0234 325 0	WASHER	11 X 21 X3	1	
12	00 0236 171 0	HEXAGONAL NUT	M10	3	
13	00 0502 119 0	TENSION SPRING	1,5 X 13,5X 33	1	
14	00 0235 090 0	SPLIT PIN	4 X 28	2	
15	00 0830 167 1	BRAKE LEVER		1	
16	00 0236 152 0	SPLIT PIN	3,2X22	1	
17	00 0244 515 0	PIN	B12H11X 45	1	
18	00 0830 149 0	TOOTHED SEGMENT		1	
19	00 0242 795 0	HEXAGON HEAD BOLT	M16X140	1	

5

Quadrant 1150

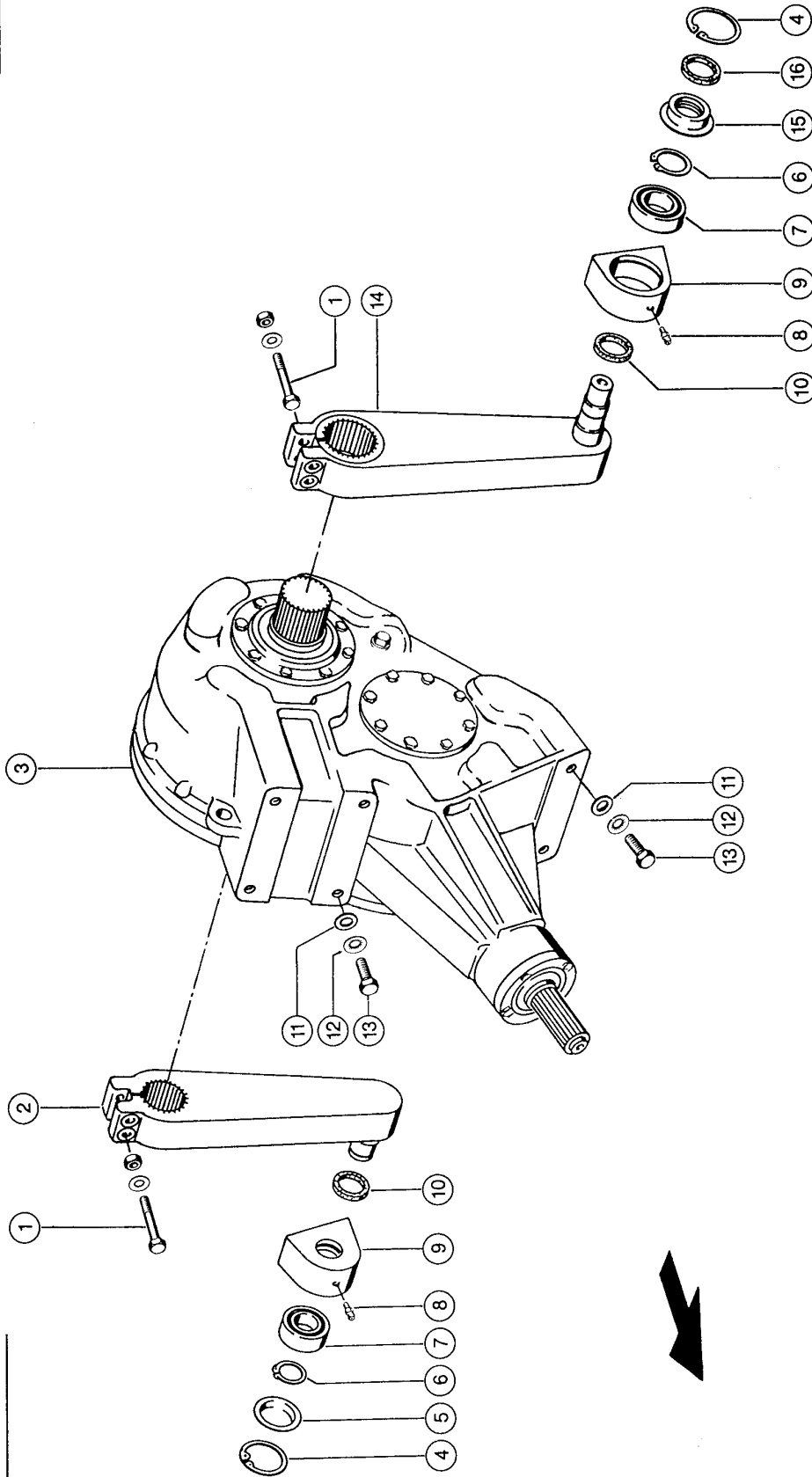

CLAAS

GEARBOX

Pos.	Part No.	Description	Dimension	Quantity	Conditions
1	00 0244 391 0	HEXAGON HEAD BOLT	M12X95	4	
1	00 0236 172 0	HEXAGONAL NUT	M12	4	
1	00 0239 389 0	CONTACT WASHER	A12	4	
2	00 0830 162 1	CRANK ARM		1	
3	00 0831 226 1	MAIN GEARBOX		1	1)
4	00 0236 318 0	CIRCLIP	80X2,5	2	
5	00 0810 710 0	COVER	D80X11	1	
6	00 0244 058 0	CIRCLIP	40X2,5	2	
7	00 0238 280 3	SPHERICAL ROLLER BEARING	22208	2	
8	00 0236 942 0	GREASE NIPPLE	E/S-C3-40X80X23 A S6X1	2	
9	00 0830 159 0	BEARING HOUSING	120X100X50	2	
10	00 0215 320 0	FELT RING	57X45XD.X5 MM	2	
11	00 0238 990 0	WASHER	Ø16,5 X Ø33,5 - 1X5	6	
11	00 0233 662 0	SHIM	17X35X0,5	6	
11	00 0238 203 0	WASHER	16,5X33X1	6	
11	00 0238 205 0	WASHER	16,5X33X2	6	
12	00 0239 391 0	CONTACT WASHER	A16	6	
13	00 0215 352 0	HEX.HEAD BOLT	M16X1,5X 45-MKL	6	
14	00 0830 161 2	CRANK ARM		1	
15	00 0830 160 1	RING	D79,8X16,5	1	
16	00 0244 652 0	FELT RING	40	1	

1) Remarks

see illustration plate 6

6

CLAAS

BGZ 01150

1

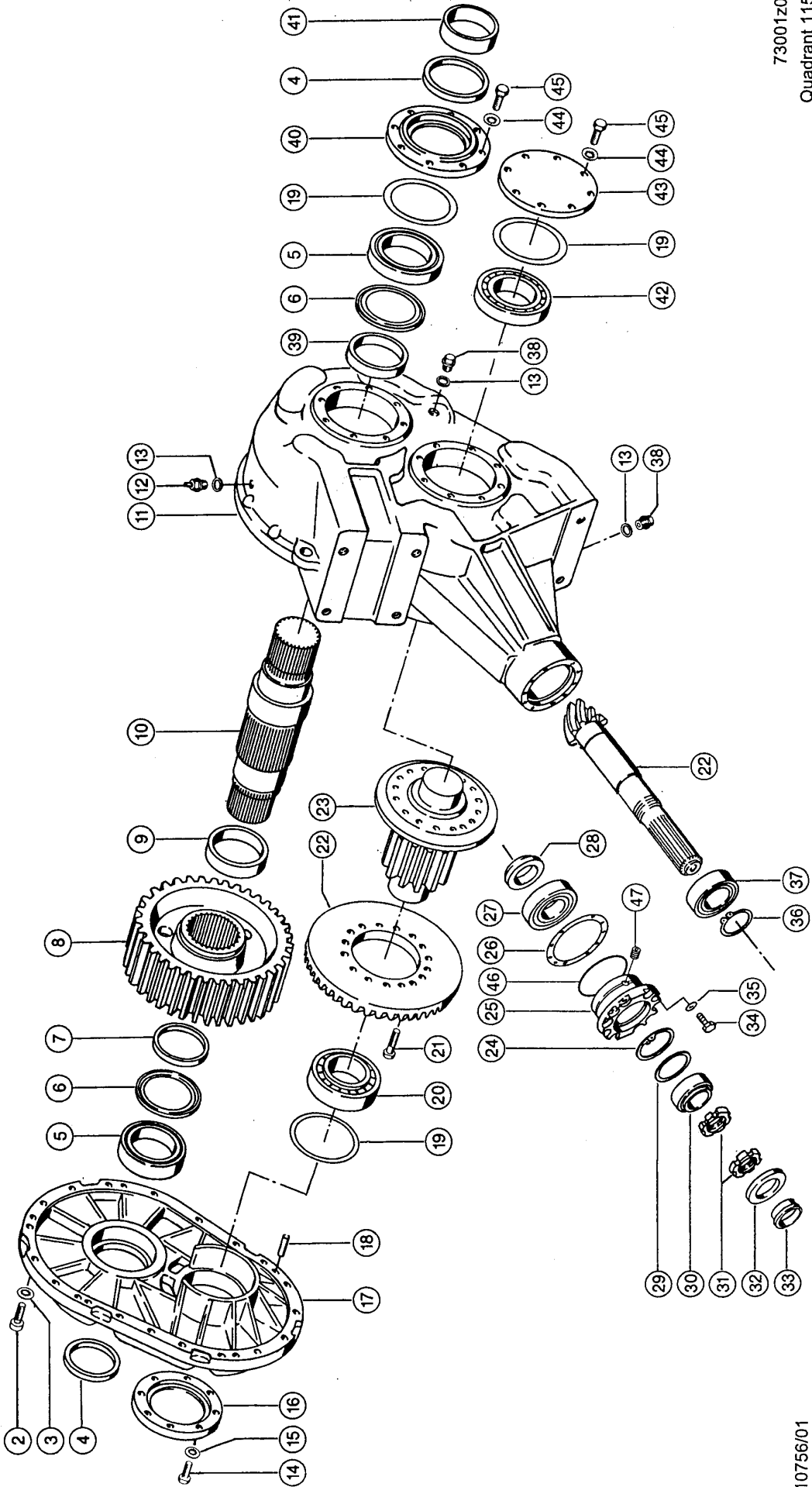

73001200
Quadrant 1150

110756/01

GEARBOX

Pos.	Part No.	Description	Dimension	Quantity	Conditions
1	00 0831 226 1	MAIN GEARBOX		1	
2	00 0242 263 0	SOCKET HEAD SCREW	M12X 45(CN 200052)REF.02	19	
3	00 0242 824 1	WASHER	12 -12,2X18,3X2,5	19	
4	00 0212 689 0	SHAFT SEAL	AS 100X120X12	2	
5	00 0215 782 0	CY.ROLLER BEARING	NCF 2920 V	2	
6	00 0215 783 0	BEARING SEAL RING	619 20 AV	2	
7	00 0830 763 0	BUSHING		1	
8	00 0830 699 0	SPUR GEAR		1	
9	00 0830 761 0	BUSHING		1	
10	00 0830 760 0	PROFILE SHAFT		1	
11	00 0830 693 2	GEARBOX HOUSING		1	
12	00 0817 304 0	BREATHER VALVE	M18X1,5	1	
13	00 0238 533 1	SEALING RING	C18 X22	3	
14	00 0237 874 0	HEXAGON HEAD BOLT	M10X35	8	
15	00 0235 133 1	SPRING WASHER	10 -10,2X18,1X1,8	8	
16	00 0830 695 0	HOUSING COVER		1	
17	00 0830 694 0	HOUSING COVER		1	
18	00 0215 784 0	SPRING PIN	12 X 40	6	
19	00 0213 606 0	SHIM	125X139X2	1	1)
19	00 0215 932 1	SHIM	118X140X1	1	2)
19	00 0215 785 2	SHIM	118X140X0,5	1	3)
19	00 0215 786 2	SHIM	118X140X0,3	1	4)
19	00 0215 787 2	SHIM	118X140X0,1	1	5)
20	00 0215 781 0	TA.ROLLER BEARING	33216-80X140X46	1	
21	00 0235 553 0	HEXAGON HEAD BOLT	M12X45	1	6)
21	00 0238 875 1	HEXAGON HEAD BOLT	M10X40	16	7)
22	00 0831 234 2	BEVEL GEAR SET	S	1	
23	00 0830 698 0	PINION SHAFT		1	
24	00 0236 318 0	CIRCLIP	80X2,5	1	
25	00 0831 229 2	COVER	D140X65	1	
26	00 0813 180 1	SHIM	111 X140 X0,9	1	8)
26	00 0813 179 0	SHIM	111X140X0,8	1	9)
26	00 0813 178 0	SHIM	111X140X0,6	1	10)
26	00 0813 177 0	SHIM	111X140X0,5	1	3)
26	00 0813 176 1	SHIM	111 X140 X0,15	1	11)
27	00 0243 695 0	TA.ROLLER BEARING	31310 J2/QCL7C	1	
28	00 0813 174 0	RING	D80X15	1	
29	00 0211 098 0	SHIM	S 68X79,5X3	1	
30	00 0236 008 0	TA.ROLLER BEARING	32010 X -50X80X20	1	
31	00 0179 845 0	SLOTTED NUT	M50X1,5	2	
32	00 0212 113 0	SHAFT SEAL	A 50X90X10	1	
33	00 0831 230 0	BUSHING	D55X23,5	1	
34	00 0215 009 0	HEXAGON HEAD BOLT	M8X1X 25	10	
35	00 0235 132 1	SPRING WASHER	8 -8,1X14,8X1,6	10	
36	00 0243 044 0	CIRCLIP	55X2	1	
37	00 0239 446 0	CY.ROLLER BEARING	NUP 2211 V -55X100X25	1	
38	00 0244 352 0	SCREW PLUG	M18X1,5	2	
39	00 0830 762 0	BUSHING		1	
40	00 0830 697 0	HOUSING COVER		1	
41	00 0212 641 0	INNER RING	IR 90X100X30	1	
42	00 0243 678 0	TA.ROLLER BEARING	T3EC080-80X140X35, 25	1	
43	00 0830 696 0	HOUSING COVER		1	

GEARBOX

Pos.	Part No.	Description	Dimension	Quantity	Conditions
44	00 0235 133 1	SPRING WASHER	10 -10,2X18,1X1,8	16	
45	00 0237 453 0	HEXAGON HEAD BOLT	M10X30	16	
46	00 0213 843 0	O-RING	104 X3 -N	1	6)
47	00 0090 121 0	SCREW PLUG	M16X1,5	1	6)
1)	Remarks		2.0 mm		
2)	Remarks		1.0 mm		
3)	Remarks		0.5 mm		
4)	Remarks		0.3 mm		
5)	Remarks		0.1 mm		
6)	Remarks		from No. 04401115		
7)	Remarks		to No. 04401115		
8)	Remarks		0.9 mm		
9)	Remarks		0.8 mm		
10)	Remarks		0.6 mm		
11)	Remarks		0.15 mm		

7

Quadrant 1150

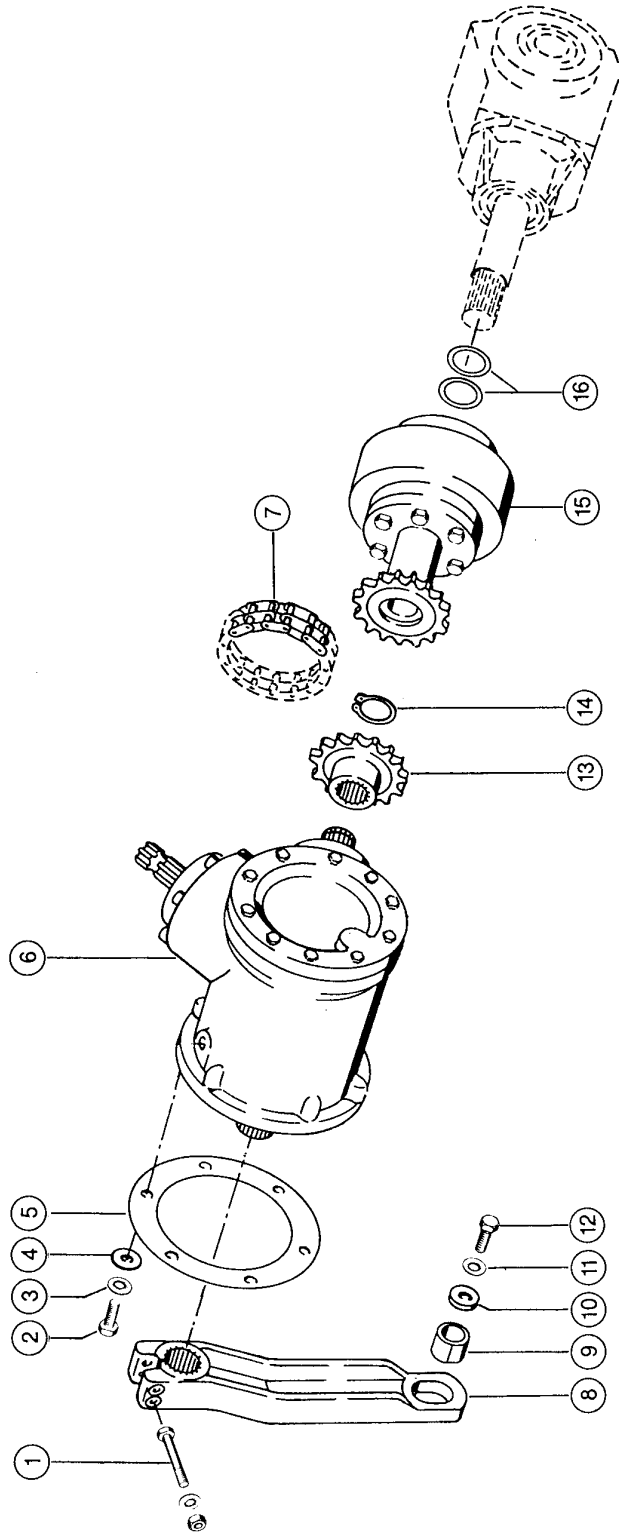

CLAAS

Thank you so much for reading.
Please click the “Buy Now!”
button below to download the
complete manual.



After you pay.

You can download the most
perfect and complete manual in
the world immediately.

Our support email:

ebooklibonline@outlook.com