

E0126 0230A500A 1

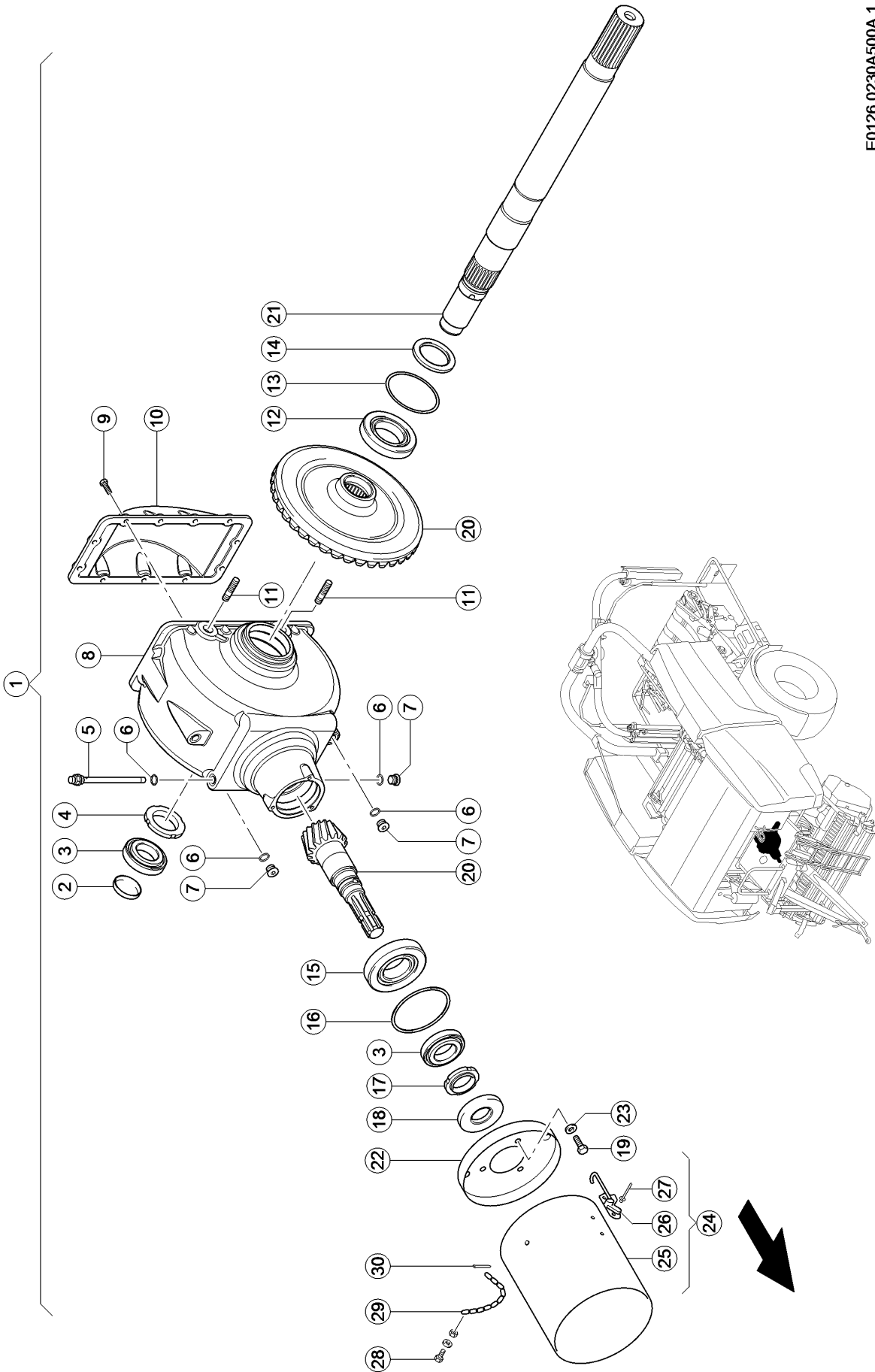

500 MAIN GEARBOX 1)

Pos.	Part No.	Description	Dimension	Quantity	Conditions
1	00 0851 724 0	GEARBOX	I=4,33 1700NM	1	
2	00 0213 767 0	LOCKING COVER	55X10	1	
3	00 0234 829 0	TA.ROLLER BEARING	30209 J2/Q	2	
4	00 0823 993 0	SLOTTED NUT	M55X1,5	1	
5	00 0827 581 0	BREATHER VALVE	1021-04-401-00	1	
6	00 0238 183 0	SEALING RING	A16 X20	4	
7	00 0244 351 0	SCREW PLUG	M16X1,5	3	
8	00 0843 461 1	HOUSING		1	
9	00 0237 442 0	HEXAGON HEAD BOLT	M8X25	12	
10	00 0843 462 0	COVER		1	
11	00 0244 014 1	STUD BOLT	M12X 45	2	
12	00 0243 661 0	TA.ROLLER BEARING	30212A	1	
13	00 0211 963 0	SHIM	100X110X0,1	1	
13	00 0211 964 0	SHIM	100X110X0,3	1	
13	00 0211 966 0	SHIM	100X110X1	1	
14	00 0211 034 0	ROTARY SHAFT SEAL	AS 60X 85X 8	1	
15	00 0243 686 0	TA.ROLLER BEARING	30311A - 55X120X31,5	1	
16	00 0214 179 0	SHIM	110X120X0,1 ERS.D. 21417	3	
16	00 0214 180 0	SHIM	110X120X0,3 ERS.D. 21418	1	
16	00 0214 181 0	SHIM	110X120X0,5 ERS.D. 21418	1	
16	00 0214 182 0	SHIM	110X120X1,0 ERS.D.214182	1	
17	00 0823 994 0	SLOTTED NUT	M45X1,5	1	
18	00 0213 766 0	SHAFT SEAL	AS 40X 90X12	1	
19	00 0237 439 0	HEXAGON HEAD BOLT	M8X16	3	
20	00 0861 268 0	BEVEL GEAR		1	
21	00 0861 269 0	SHAFT		1	
22	00 0843 463 0	GUARD CUP	D206X1.5	1	2)
22	00 0861 270 0	ADAPTER		1	3)
23	00 0239 387 0	CONTACT WASHER	A8-8,2X18X1,4	3	2)
24	00 0822 996 0	PROTECT.TUBE CPL.		1	2)
25	00 0822 997 1	PROTECTIVE TUBE	200X4X235	1	2)
26	00 0822 998 1	LOCK		2	2)
27	00 0237 922 1	BLIND RIVET	A 4X12	4	2)
28	00 0233 918 0	HEXAGON HEAD BOLT	M 5X16	1	4)
28	00 0236 910 2	FLAT WASHER	5 -5,3X10X1	1	4)
28	00 0237 216 0	HEXAGONAL NUT	M05	1	4)
29	00 0608 099 0	ROUND STEEL CHAIN	G 3X16-17GL	1	4)
30	00 0235 089 0	SPLIT PIN	4 X 22	1	4)

1) Equipment

PR_P08_0020

Input gearbox 1,000 rpm

2) machine no.

+ from 76900022

3) machine no.

+ up to 76900021

4) machine no.

+ from 76900022 up to 76900025

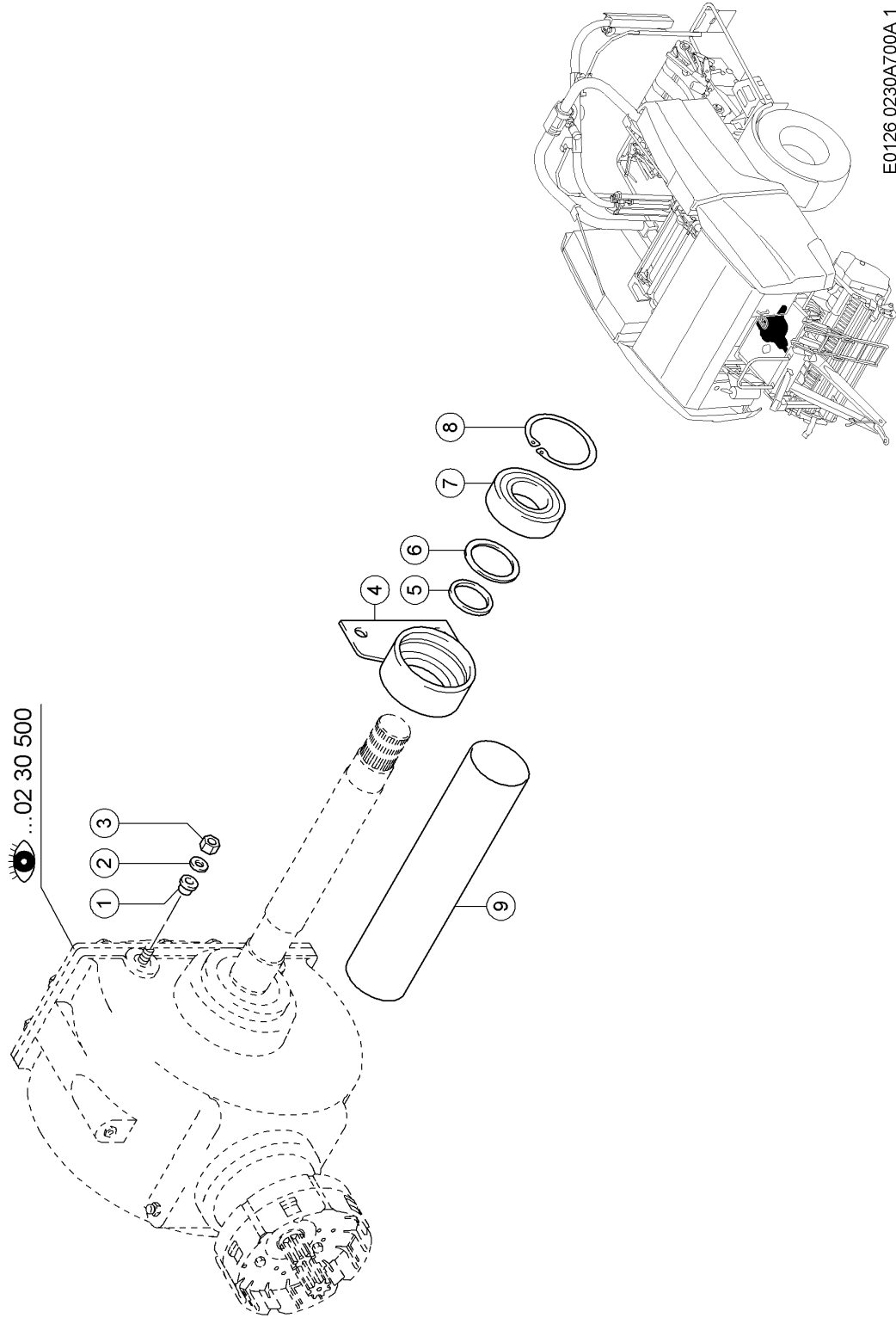

E0126 0230A700A 1

700 FASTENINGS / ATTACHMENT PARTS

Pos.	Part No.	Description	Dimension	Quantity	Conditions
1	00 0810 117 0	BUSHING	D30X20	2	
2	00 0239 389 0	CONTACT WASHER	A12	2	
3	00 0236 172 0	HEXAGONAL NUT	M12	2	
4	00 0851 990 0	BEARING		1	
5	00 0234 389 0	BACK-UP WASHER	S 60X 75	1	
6	00 0233 517 0	SHIM	90X110X1	1	
7	00 0215 768 0	GRVD.BALL BEARING	6312-2RS*	1	
8	00 0243 065 0	CIRCLIP	130X4	1	
9	00 0851 984 0	PROTECTIVE TUBE		1	

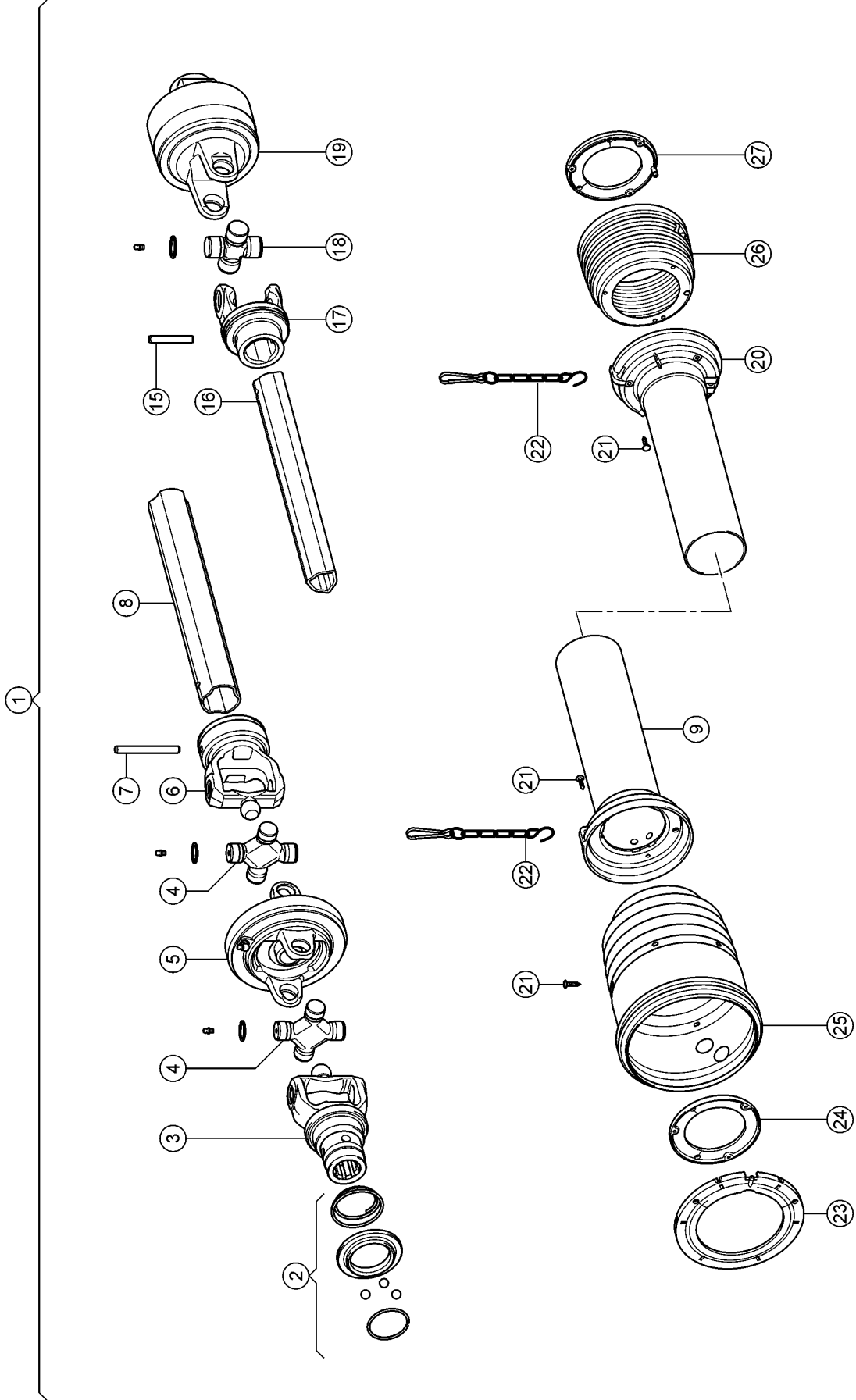

100 DRIVE SHAFT, MAIN DRIVE 1)

Pos.	Part No.	Description	Dimension	Quantity	Conditions
1	00 0866 126 0	DRIVE SHAFT		1	2)
1	00 0866 033 1	DRIVE SHAFT		1	3)
2	00 0150 166 0	DISCONNECT LOCK		1	
3	00 0843 764 0	FORK		1	
4	00 0139 080 0	CENTRE CROSS ASS.		2	
5	00 0843 767 0	FORK		1	
6	00 0843 766 0	INNER FORK		1	
7	00 0233 750 0	SPRING PIN	10 X 95	1	
8	00 0866 330 0	TUBE		1	
9	00 0866 333 0	PROTECTIVE TUBE		1	
15	00 0244 579 0	SPRING PIN	10X65	1	
16	00 0866 331 0	TUBE		1	
17	00 0843 772 0	FORK		1	
18	00 0138 065 0	CENTRE CROSS ASS.		1	
19	00 0866 332 0	CLUTCH		1	
20	00 0866 334 0	PROTECTIVE TUBE		1	
21	00 0214 631 0	FILL.HEAD SCREW	ST4,8X22-C-H	12	
22	00 0148 626 0	SUPPORTING CHAIN		2	
23	00 0844 557 0	RING		1	
24	00 0844 558 0	RING		1	
25	00 0150 165 0	PROTECT.FUNNEL		1	
26	00 0138 197 0	PROTECT.FUNNEL		1	
27	00 0138 199 0	RING		1	

1) Equipment

PR_M04_0240

Single wide-angle PTO drive shaft with cam clutch, 1700 Nm

PR_M04_0370

Single wide-angle PTO drive shaft with cam clutch, 6 splines

2) machine no.

+ from 76900022

3) machine no.

+ up to 76900021

E0126 0260A100A.2

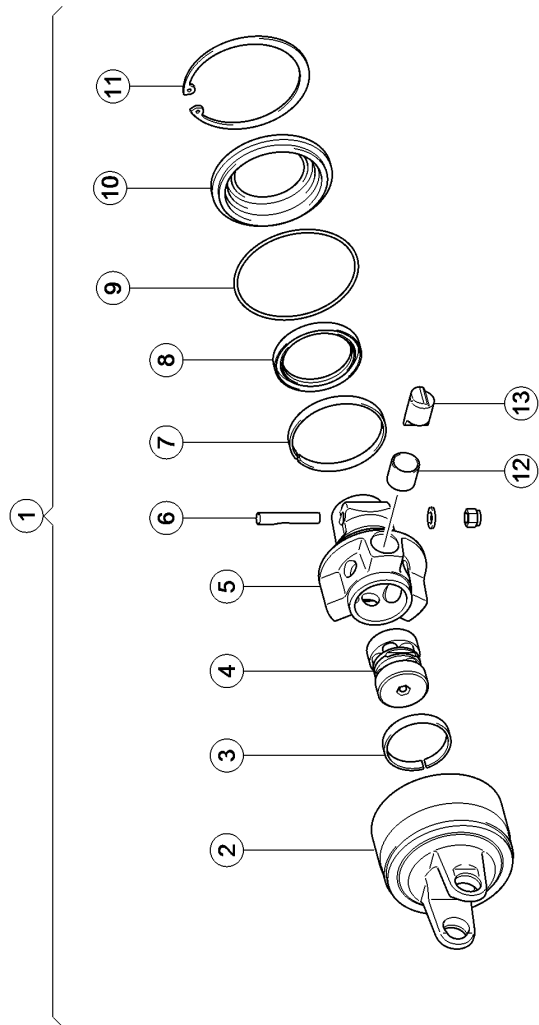

100 DRIVE SHAFT, MAIN DRIVE 1)

Pos.	Part No.	Description	Dimension	Quantity	Conditions
1	00 0866 332 0	CLUTCH		1	
2	00 0866 335 0	CLUTCH HOUSING		1	
3	00 0836 414 0	RING		1	
4	00 0843 798 0	SPRING KIT		1	
5	00 0843 781 0	HUB		1	
6	00 0843 782 0	CLAMPING SCREW		1	
7	00 0843 783 0	RING		1	
8	00 0843 784 0	SEALING RING		1	
9	00 0843 785 0	O-RING		1	
10	00 0843 786 0	COVER		1	
11	00 0214 628 0	CIRCLIP	138X4	1	
12	00 0836 417 0	BUSHING		1	
13	00 0836 416 0	BLOCK, BODY		1	
1) Equipment					
		PR_M04_0240			Single wide-angle PTO drive shaft with cam clutch, 1700 Nm
		PR_M04_0370			Single wide-angle PTO drive shaft with cam clutch, 6 splines

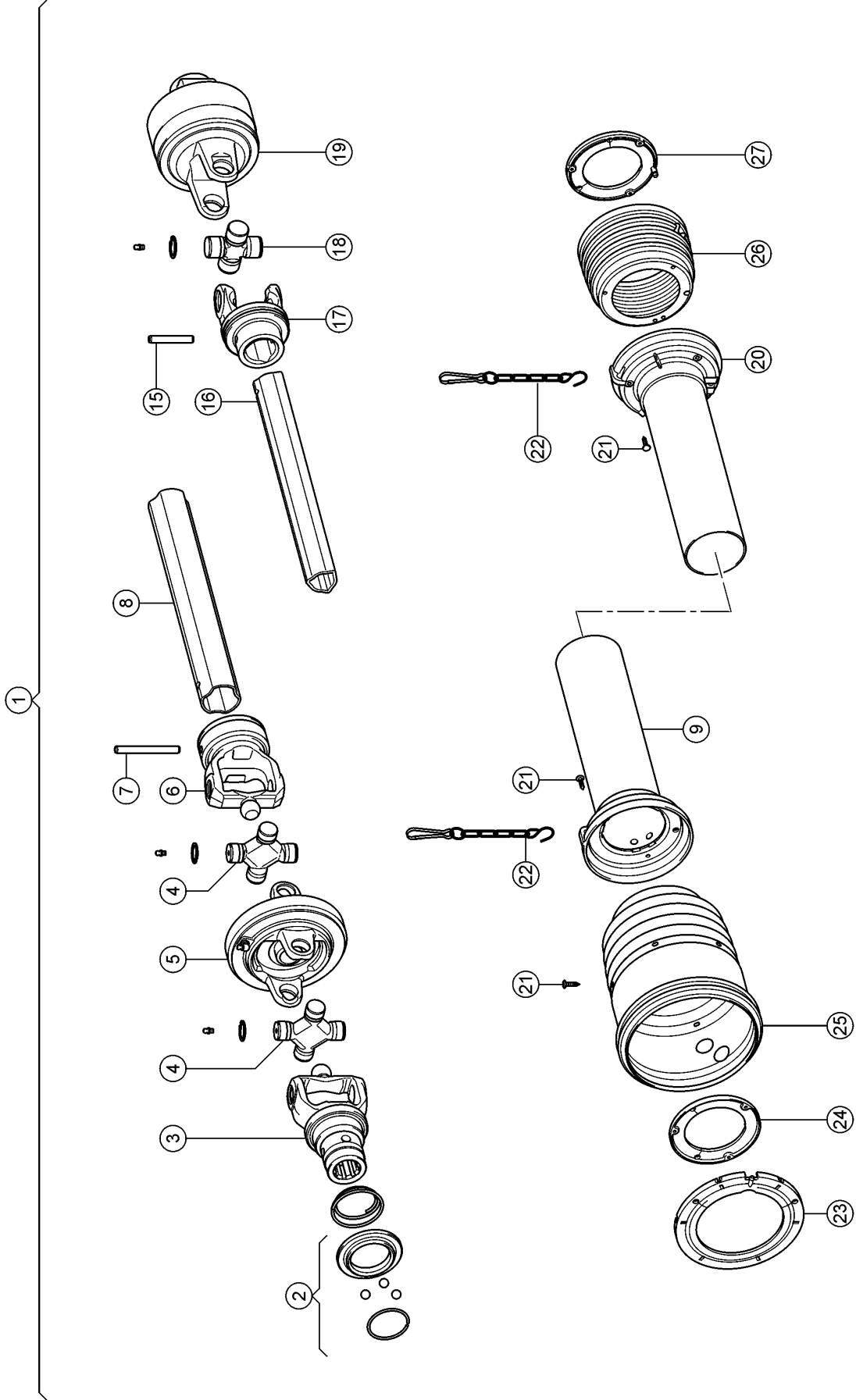

100 DRIVE SHAFT, MAIN DRIVE 1)

Pos.	Part No.	Description	Dimension	Quantity	Conditions
1	00 0866 127 0	DRIVE SHAFT		1	2)
1	00 0866 034 1	DRIVE SHAFT	WWE-21TLG 1700NM	1	3)
2	00 0150 166 0	DISCONNECT LOCK		1	
3	00 0843 792 0	FORK		1	
4	00 0139 080 0	CENTRE CROSS ASS.		2	
5	00 0843 767 0	FORK		1	
6	00 0843 766 0	INNER FORK		1	
7	00 0233 750 0	SPRING PIN	10 X 95	1	
8	00 0866 330 0	TUBE		1	
9	00 0866 333 0	PROTECTIVE TUBE		1	
15	00 0244 579 0	SPRING PIN	10X65	1	
16	00 0866 331 0	TUBE		1	
17	00 0843 772 0	FORK		1	
18	00 0138 065 0	CENTRE CROSS ASS.		1	
19	00 0866 332 0	CLUTCH		1	
20	00 0866 334 0	PROTECTIVE TUBE		1	
21	00 0214 631 0	FILL.HEAD SCREW	ST4,8X22-C-H	12	
22	00 0148 626 0	SUPPORTING CHAIN		2	
23	00 0844 557 0	RING		1	
24	00 0844 558 0	RING		1	
25	00 0150 165 0	PROTECT.FUNNEL		1	
26	00 0138 197 0	PROTECT.FUNNEL		1	
27	00 0138 199 0	RING		1	

1) Equipment

PR_M04_0250

Single wide-angle PTO drive shaft with cam clutch, 1700 Nm

PR_M04_0390

Single wide-angle PTO drive shaft with cam clutch, 21 splines

2) machine no.

+ from 76900022

3) machine no.

+ up to 76900021

E0126 0260A100B 2

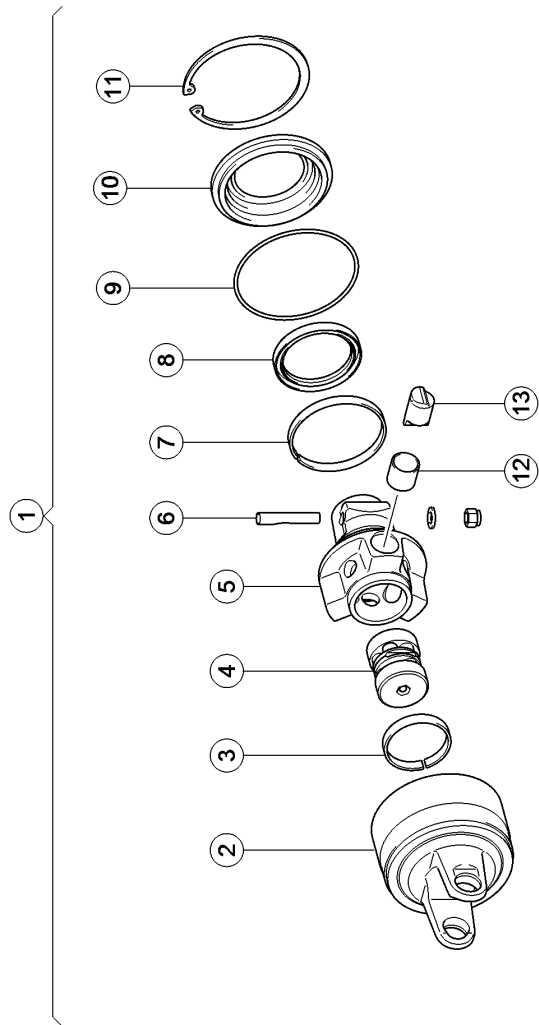

100 DRIVE SHAFT, MAIN DRIVE 1)

Pos.	Part No.	Description	Dimension	Quantity	Conditions
1	00 0866 332 0	CLUTCH		1	
2	00 0866 335 0	CLUTCH HOUSING		1	
3	00 0836 414 0	RING		1	
4	00 0843 798 0	SPRING KIT		1	
5	00 0843 781 0	HUB		1	
6	00 0843 782 0	CLAMPING SCREW		1	
7	00 0843 783 0	RING		1	
8	00 0843 784 0	SEALING RING		1	
9	00 0843 785 0	O-RING		1	
10	00 0843 786 0	COVER		1	
11	00 0214 628 0	CIRCLIP	138X4	1	
12	00 0836 417 0	BUSHING		1	
13	00 0836 416 0	BLOCK, BODY		1	
1) Equipment					
		PR_M04_0250			Single wide-angle PTO drive shaft with cam clutch, 1700 Nm
		PR_M04_0390			Single wide-angle PTO drive shaft with cam clutch, 21 splines

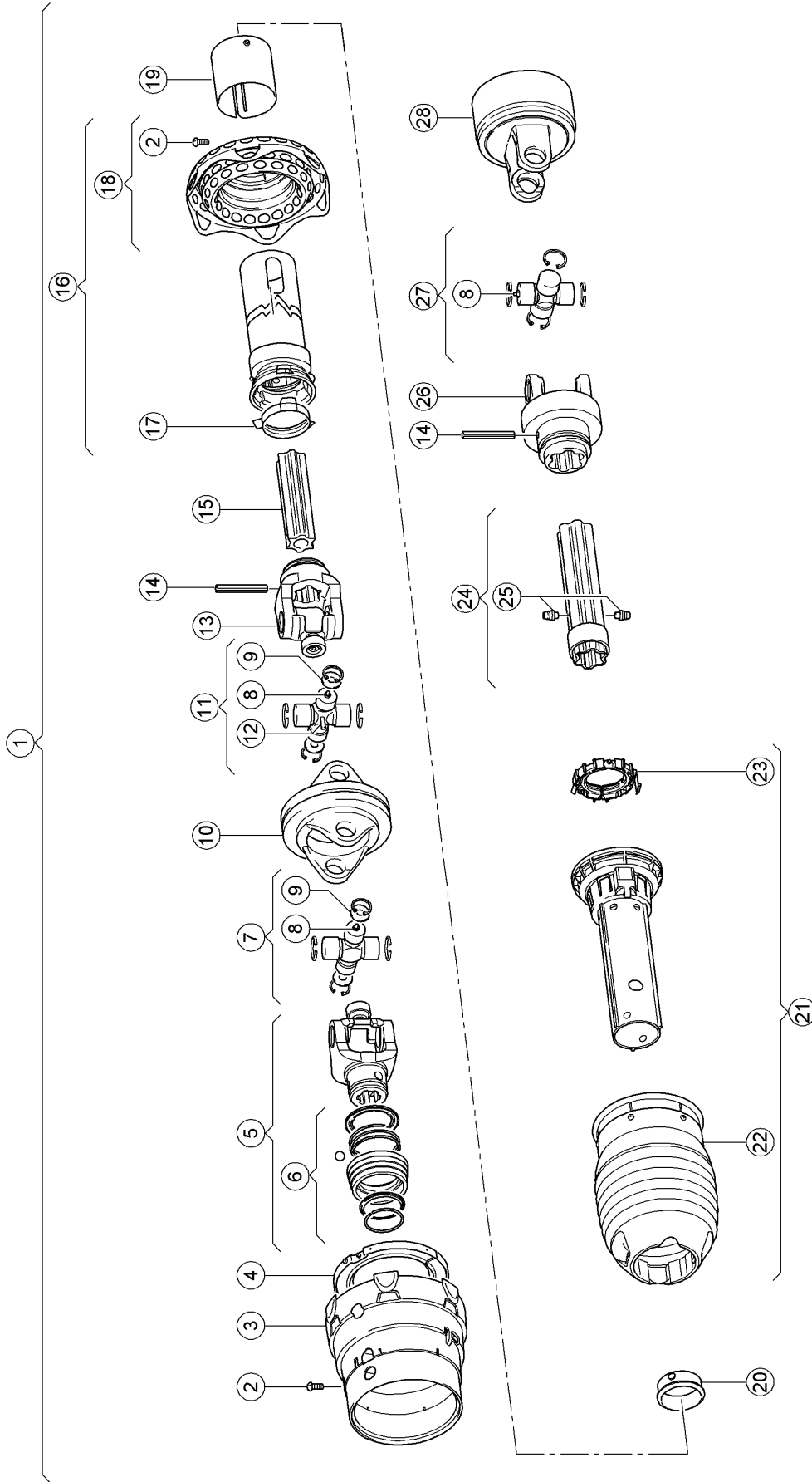

E0126 0260A100C 1

100 DRIVE SHAFT, MAIN DRIVE 1)

Pos.	Part No.	Description	Dimension	Quantity	Conditions
1	00 0860 912 0	DRIVE SHAFT		1	
2	00 0850 548 0	SCREW		9	
3	00 0139 111 0	PROTECT.FUNNEL		1	
4	00 0821 098 0	GLIDE RING		1	
5	00 0861 496 0	FORK ASSY.		1	
6	00 0851 416 0	DISCONNECT LOCK		1	
7	00 0139 105 0	CENTRE CROSS ASS.		1	
8	00 0219 880 0	GREASE NIPPLE	A M6X1-GEW.-LAENGE =3,5	3	
9	00 0921 267 0	WASHER		4	
10	00 0139 106 0	DOUBLE FORK		1	
11	00 0139 107 0	CENTRE CROSS ASS.		1	
12	00 0817 783 0	GREASE NIPPLE		1	
13	00 0139 108 0	FORK		1	
14	00 0244 581 2	SPRING PIN	10X 80	2	
15	00 0861 493 0	PROFILE SHAFT		1	
16	00 0861 489 0	UNIVERSAL DRIVE SHAFT HALF		1	
17	00 0920 671 0	GLIDE RING		1	
18	00 0139 031 0	PROTECT.FUNNEL		1	
19	00 0138 544 0	COVERING		1	
20	00 0138 554 0	GLIDE RING		1	
21	00 0861 490 0	UNIVERSAL DRIVE SHAFT HALF		1	
22	00 0138 950 0	PROTECT.FUNNEL		1	
23	00 0138 539 0	GLIDE RING		1	
24	00 0861 494 0	PROFILE TUBE		1	
25	00 0817 786 0	GREASE NIPPLE		2	
26	00 0861 495 0	ALIGNMENT CLUTSCH		1	
27	00 0920 191 0	CENTRE CROSS ASS.		1	
28	00 0861 492 0	CAM CLUTCH		1	

1) Equipment**machine no.**

PR_M04_0240

Single wide-angle PTO drive shaft with cam clutch, 1700 Nm
+ up to 76900020

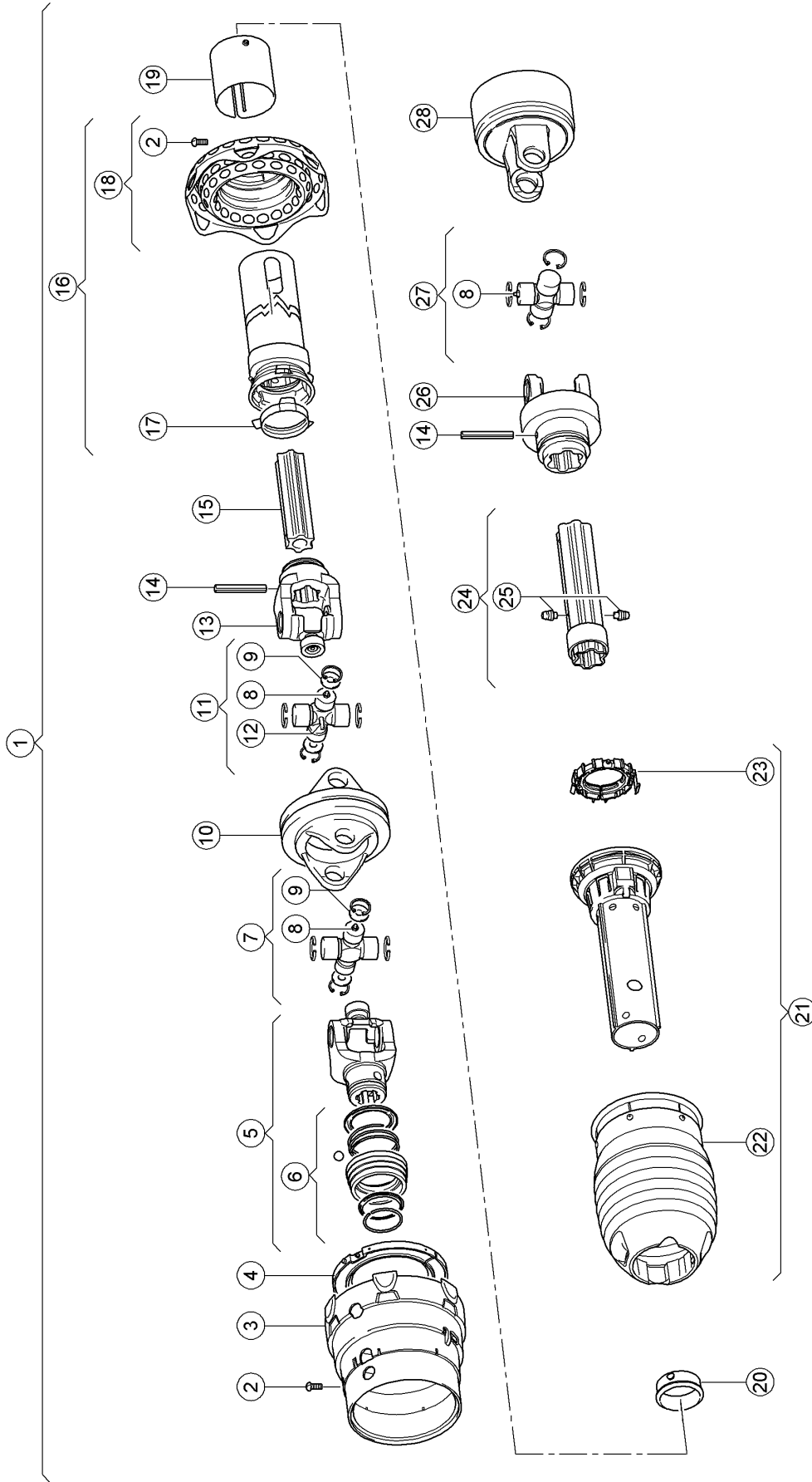

E0126 0260A100D 1

100 DRIVE SHAFT, MAIN DRIVE 1)

Pos.	Part No.	Description	Dimension	Quantity	Conditions
1	00 0860 913 0	DRIVE SHAFT		1	
2	00 0850 548 0	SCREW		9	
3	00 0139 111 0	PROTECT.FUNNEL		1	
4	00 0821 098 0	GLIDE RING		1	
5	00 0861 491 0	FORK ASSY.		1	
6	00 0851 416 0	DISCONNECT LOCK		1	
7	00 0139 105 0	CENTRE CROSS ASS.		1	
8	00 0219 880 0	GREASE NIPPLE	A M6X1-GEW.-LAENGE =3,5	3	
9	00 0921 267 0	WASHER		4	
10	00 0139 106 0	DOUBLE FORK		1	
11	00 0139 107 0	CENTRE CROSS ASS.		1	
12	00 0817 783 0	GREASE NIPPLE		1	
13	00 0139 108 0	FORK		1	
14	00 0244 581 2	SPRING PIN	10X 80	2	
15	00 0861 493 0	PROFILE SHAFT		1	
16	00 0861 489 0	UNIVERSAL DRIVE SHAFT HALF		1	
17	00 0920 671 0	GLIDE RING		1	
18	00 0139 031 0	PROTECT.FUNNEL		1	
19	00 0138 544 0	COVERING		1	
20	00 0138 554 0	GLIDE RING		1	
21	00 0861 490 0	UNIVERSAL DRIVE SHAFT HALF		1	
22	00 0138 950 0	PROTECT.FUNNEL		1	
23	00 0138 539 0	GLIDE RING		1	
24	00 0861 494 0	PROFILE TUBE		1	
25	00 0817 786 0	GREASE NIPPLE		2	
26	00 0861 495 0	ALIGNMENT CLUTSCH		1	
27	00 0920 191 0	CENTRE CROSS ASS.		1	
28	00 0861 492 0	CAM CLUTCH		1	

1) Equipment

machine no.

PR_M04_0250

Single wide-angle PTO drive shaft with cam clutch, 1700 Nm
+ up to 76900020

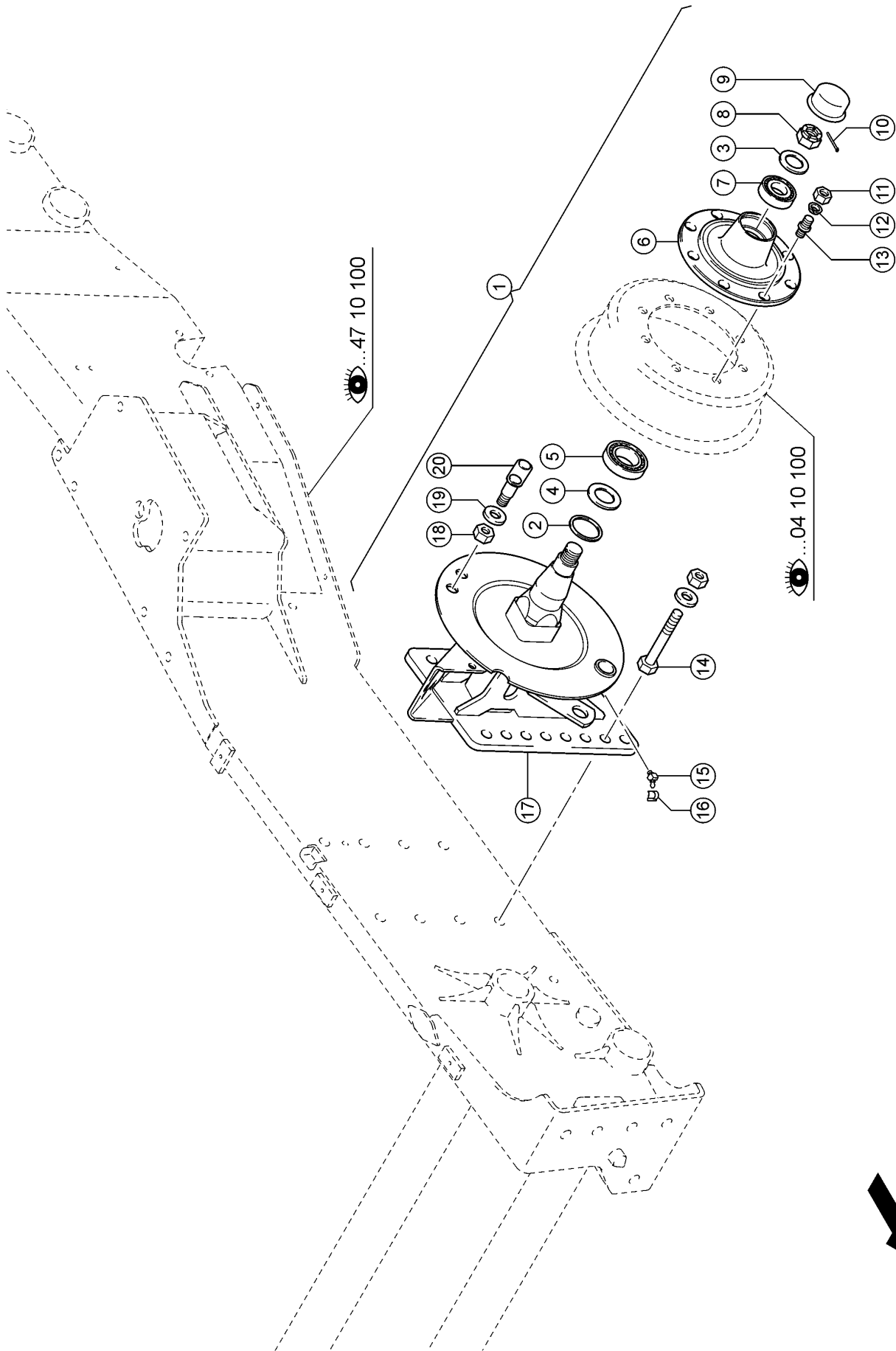

100 SINGLE AXLE

Pos.	Part No.	Description	Dimension	Quantity	Conditions
1	00 1328 527 0	FUSEE DE ROUE GA MO	LINKS	1	1)
1	00 0852 996 1	BR.SHAFT JOURNAL	LINKS	1	2)
1	00 1328 528 0	FUSEE DE ROUE DR MO	RECHTS	1	3)
1	00 0852 997 1	BR.SHAFT JOURNAL	RECHTS	1	4)
2	00 0850 809 0	GASKET		2	
3	00 0933 306 0	RING	66X37X5	2	
4	00 0817 572 0	RING		2	
5	00 0243 655 0	TA.ROLLER BEARING	32014-X	2	
6	00 0933 307 0	HUB		2	
7	00 0235 989 0	TA.ROLLER BEARING	30210 - 50X90X21,75	2	
8	00 0850 821 0	CASTELLATED NUT	M36X1.5	2	
9	00 0940 800 0	WHEEL CAP	D 90,1	2	
10	00 0235 098 0	SPLIT PIN	6,3X 63	2	
11	00 0106 219 0	FLAT COLLAR NUT	B20 - M20X1,5	16	
12	00 0634 471 0	SPRING WASHER	C 20,5X34X8	16	
13	00 0841 134 0	WHEEL BOLT	M20X1,5X 70	16	
14	00 0242 408 0	HEXAGON HEAD BOLT	M20X100	12	
14	00 0212 191 0	CONTACT WASHER	A20	12	
14	00 0233 551 0	LOCK NUT	M20	12	
15	00 0214 416 0	GREASE NIPPLE	B S8X1	2	
16	00 0212 948 0	CAP	GPN985 -B- ROT	2	
17	00 1328 533 0	AXLE SPINDLE	LINKS	1	1)
17	00 0866 009 0	AXLE SPINDLE	LINKS	1	2)
17	00 1328 545 0	AXLE SPINDLE	RECHTS	1	3)
17	00 0866 010 0	AXLE SPINDLE	RECHTS	1	4)
18	00 1328 536 0	SELF-LOCKING NUT	VM 24X1,5/980	2	5)
19	00 1328 546 0	CIRCLIP	126/26	2	5)
20	00 1328 535 0	THREADED BOLT	D30 L110 M24X1,5	2	5)

1) machine no. + from 76900101
left

2) machine no. + up to 76900100
left

3) machine no. + from 76900101
right

4) machine no. + up to 76900100
right

5) machine no. + from 76900101

E0126 0350A100A 1

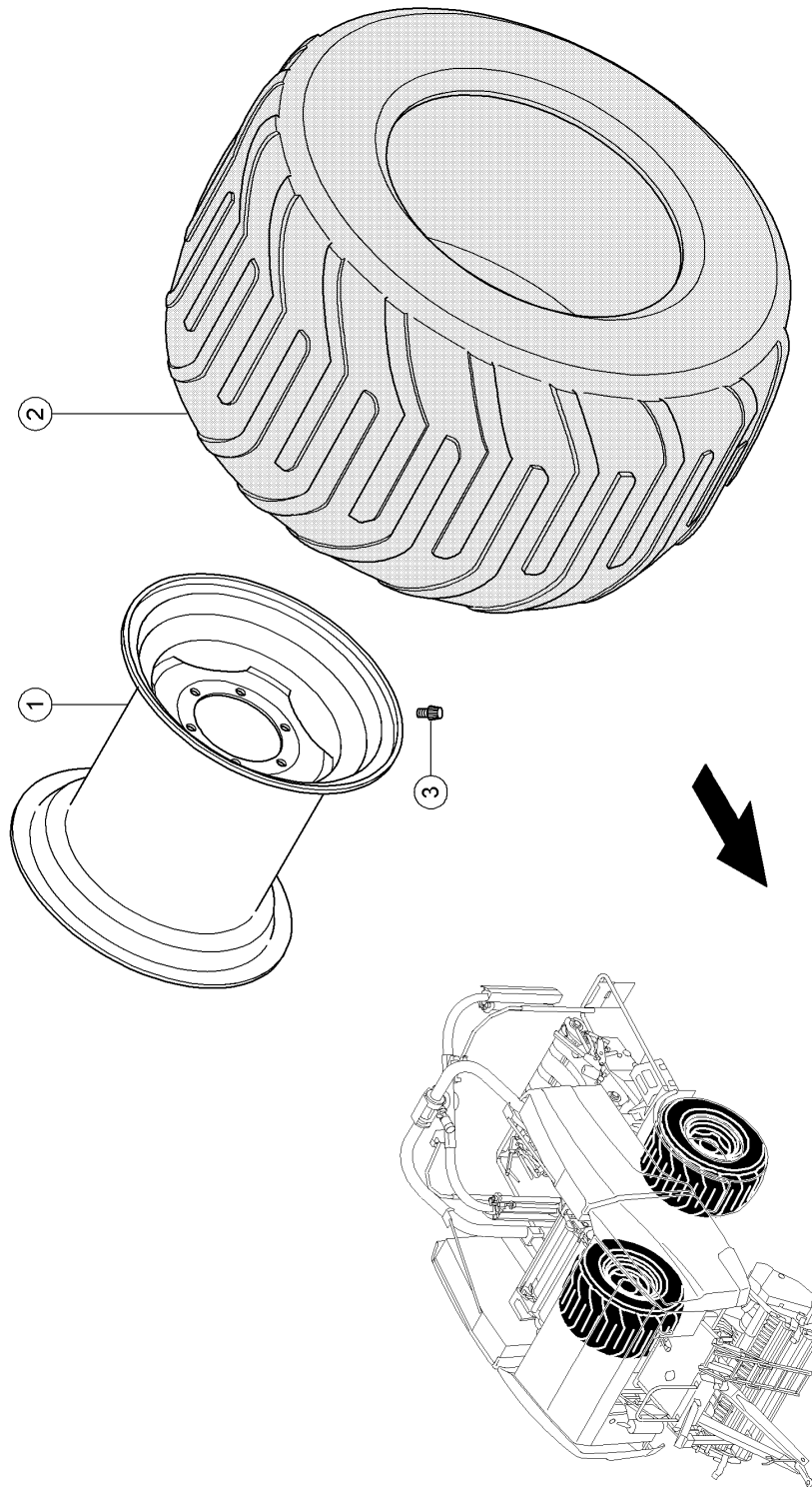

100 TYRES, WHEEL RIMS

Pos.	Part No.	Description	Dimension	Quantity	Conditions
1	00 0860 835 0	WHEEL RIM	20,00X26,5 8L	2	1)
1	00 0860 837 0	WHEEL RIM	16,00X22,5 8L	2	2)
2	00 0860 834 0	TYRE	600/55-26,5	2	1)
2	00 0860 836 0	TYRE	550/60-22,5	2	2)
2	00 0859 549 0	TYRE	620/55R26.5 166D	2	3)
3	00 0970 038 0	RUBBER VALVE	TR-618A	2	
1) Equipment					
		PR_N10_0290	Tyres 600/55-26,5		
2) Equipment					
		PR_N10_0280	550/60-22.5 tyres		
3) Equipment					
		PR_N10_0300	620/55 R26.5 tyres		

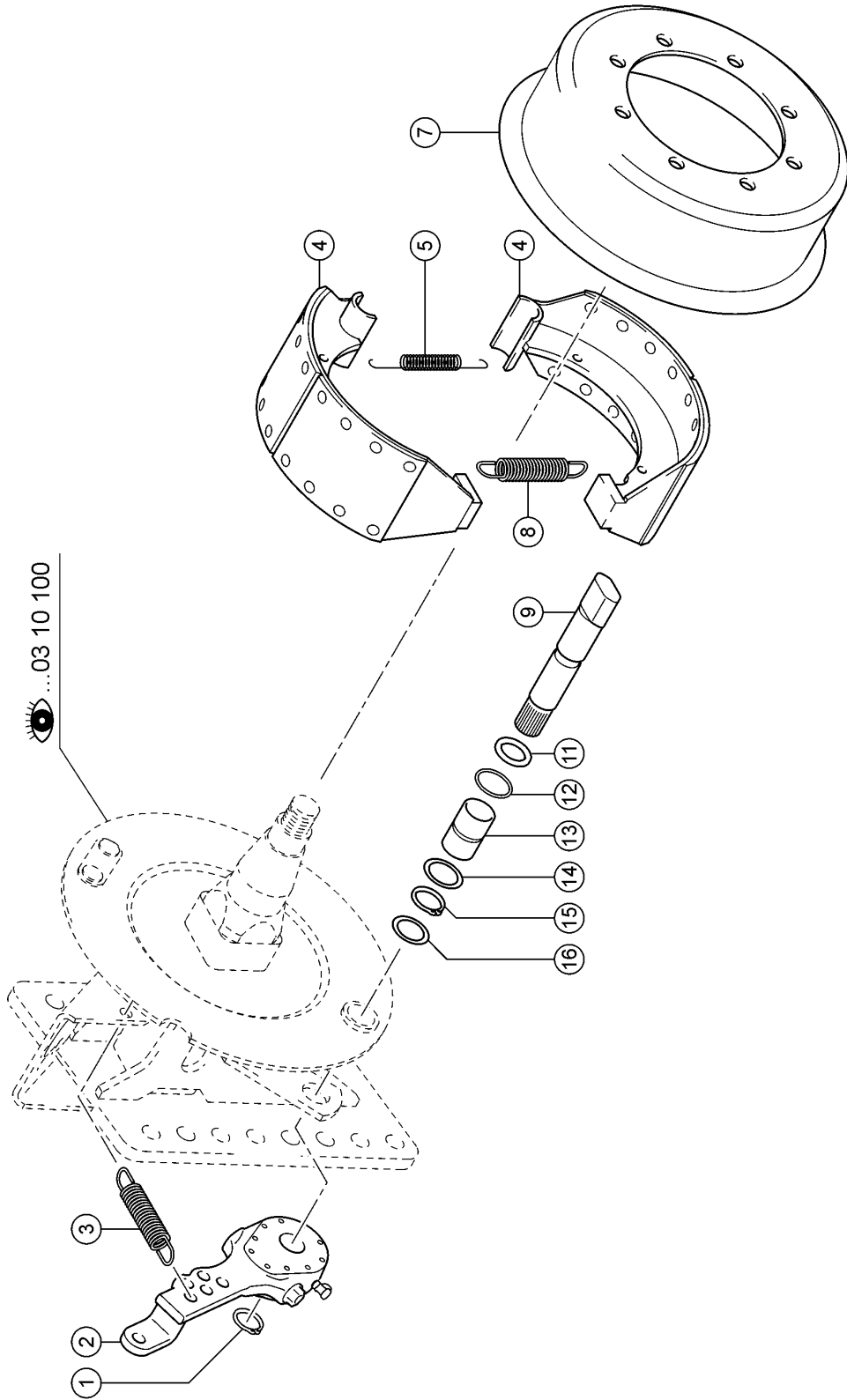

Thank you so much for reading.
Please click the “Buy Now!”
button below to download the
complete manual.



After you pay.

You can download the most
perfect and complete manual in
the world immediately.

Our support email:

ebooklibonline@outlook.com