

1

CLAAS

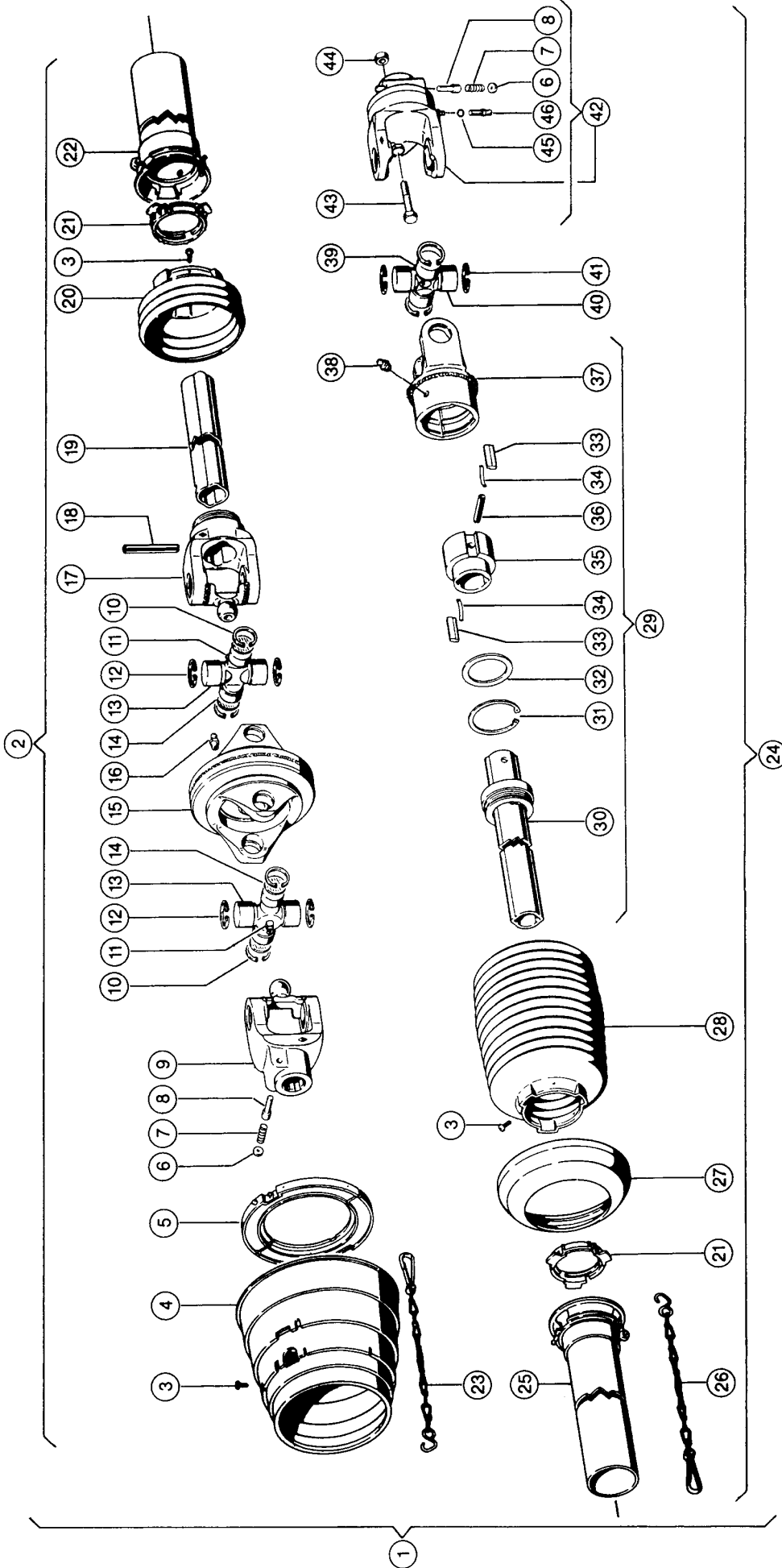

Variant 180

115355

UNIVERSAL DRIVE SHAFT WITH SHEAR BOLT CL 1)

Pos.	Part No.	Description	Dimension	Quantity	Conditions
1	00 0822 960 1	DRIVE SHAFT ASSY.		1	2)
1	00 0827 730 0	DRIVE SHAFT ASSY.		1	3)
2	00 0822 961 0	DRIVE SHAFT HALF		1	4)
2	00 0822 966 0	DRIVE SHAFT HALF		1	5)
3	00 0242 793 0	CYCL. PLATE SCREW	C4,2X 9,5	8	
4	00 0821 097 0	PROTECT.FUNNEL		1	
5	00 0821 098 0	GLIDE RING		1	
6	00 0813 698 0	WASHER		2	
7	00 0813 697 0	COMPRESS.SPRING		2	
8	00 0813 696 0	SLIDING PIN		2	
9	00 0941 475 0	EXTENSION FORKE		1	2)
9	00 0834 032 0	CLAMPING CONE	CC 1 3/8"	1	3)
10	00 0972 503 0	CIRCLIP		4	
11	00 0244 946 0	GREASE NIPPLE	B M8X1	2	
12	00 0242 908 0	CIRCLIP	32X1,2	4	
13	00 0820 421 0	CENTRE CROSS ASS.		2	
14	00 0921 267 0	WASHER		4	
15	00 0921 268 0	DOUBLE FORK		1	
16	00 0244 946 0	GREASE NIPPLE	B M8X1	1	
17	00 0941 486 0	FORK		1	
18	00 0244 581 2	SPRING PIN	10X 80	1	
19	00 0941 507 0	PROFILE TUBE		1	6)
20	00 0821 103 0	PROTECT.FUNNEL		1	
21	00 0920 671 0	GLIDE RING		2	
22	00 0824 446 0	PROTECTIVE TUBE		1	7)
23	00 0821 104 0	SUPPORTING CHAIN		1	
24	00 0827 051 0	DRIVE SHAFT HALF		1	8)
25	00 0823 180 0	GUARD HALF		1	7)
26	00 0972 297 0	SUPPORTING CHAIN		1	
27	00 0917 283 0	BACK-UP RING		1	
28	00 0813 018 1	PROTECT.FUNNEL		1	
29	00 0824 457 0	KEYOVERRUN CLUTCH		1	
30	00 0824 458 0	PROFILE TUBE		1	
31	00 0235 186 0	CIRCLIP	72X2,5	1	
32	00 0234 388 0	BACK-UP WASHER	S 56X 72	1	
33	00 0814 228 0	STOP KEY		2	
34	00 0814 229 0	FLAT SPRING		2	
35	00 0813 015 0	HUB		1	
36	00 0213 698 0	SPRING PIN	W.ERS.D.2136981	1	
37	00 0823 186 0	CLUTCH HOUSING		1	2)
37	00 0824 477 0	CLUTCH HOUSING		1	3)
38	00 0244 946 0	GREASE NIPPLE	B M8X1	1	
39	00 0244 946 0	GREASE NIPPLE	B M8X1	1	
40	00 0941 651 0	CENTRE CROSS ASS.		1	
41	00 0242 908 0	CIRCLIP	32X1,2	4	
42	00 0827 077 0	SHEAR BOLT CLUTCH		1	
43	00 0235 521 0	HEXAGON HEAD BOLT	M8-60	1	
44	00 0238 132 0	LOCK NUT	M8	1	
45	00 0238 635 0	STEEL BALL	7,938 G28	24	
46	00 0941 090 0	GREASE NIPPLE		1	

1) Remarks

6 TEIL. ANSCHLUSS
8 TEIL. ANSCHLUSS

UNIVERSAL DRIVE SHAFT WITH SHEAR BOLT CL 1)

2) Remarks	6 piece connection
3) Remarks	8 TEIL. ANSCHLUSS
4) Remarks	tractor side 6 piece connection
5) Remarks	SCHLEPPERSEITE 8 TEIL. ANSCHLUSS
6) Remarks	1045 long
7) Remarks	1000 long
8) Remarks	machine side

2

CLHHS

VARIANT 180 / RC

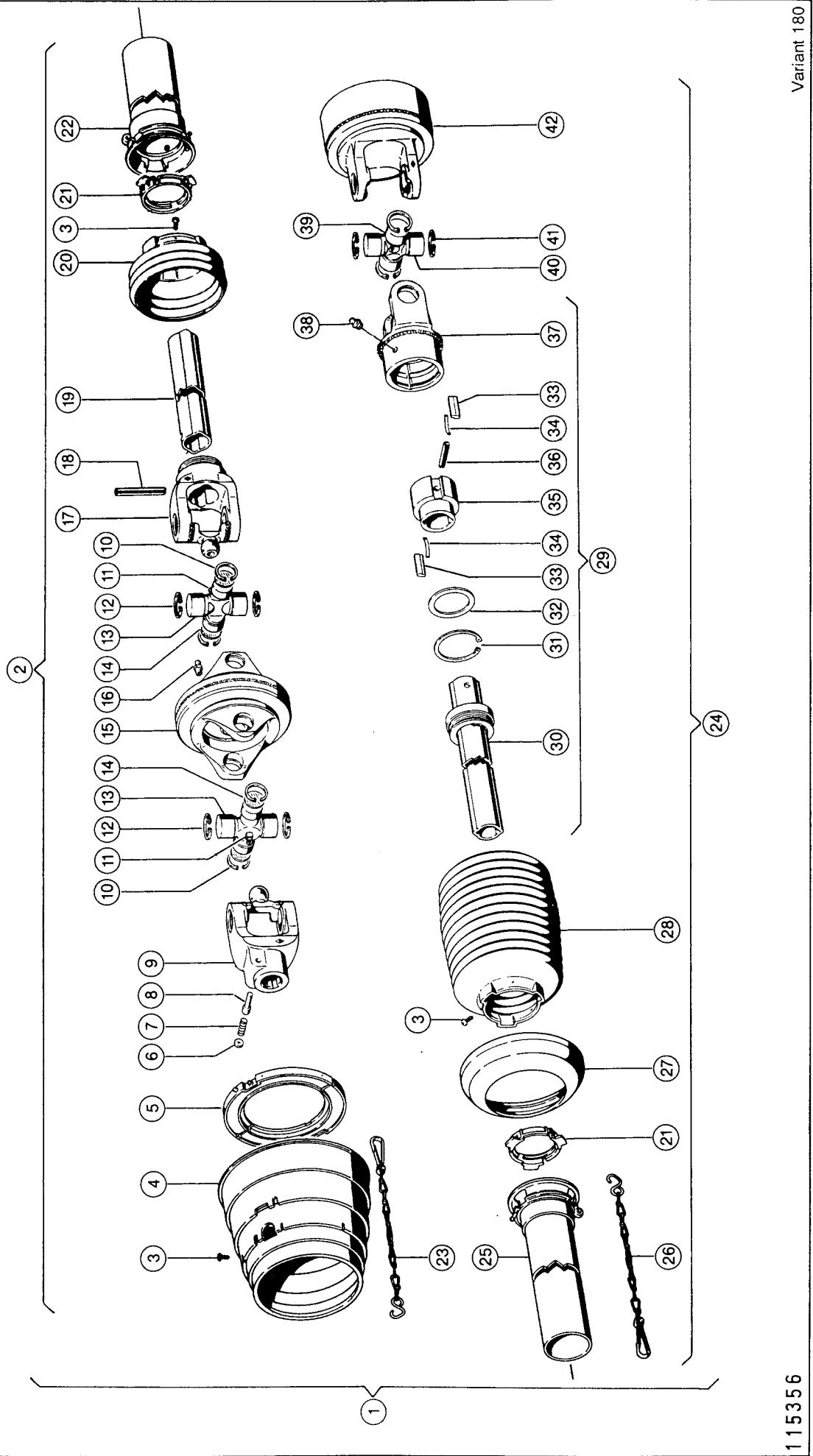

Variant 180

1 15356

UNIVERSAL DRIVE SHAFT WITH CUT - OUT CLU 1)

Pos.	Part No.	Description	Dimension	Quantity	Conditions
1	00 0827 170 0	DRIVE SHAFT ASSY.		1	2)
1	00 0827 731 0	DRIVE SHAFT ASSY.		1	3)
1	00 0827 233 0	DRIVE SHAFT ASSY.		1	4)
2	00 0822 961 0	DRIVE SHAFT HALF		1	5)
2	00 0822 966 0	DRIVE SHAFT HALF		1	6)
3	00 0242 793 0	CYCL. PLATE SCREW	C4,2X 9,5	8	
4	00 0821 097 0	PROTECT.FUNNEL		1	
5	00 0821 098 0	GLIDE RING		1	
6	00 0813 698 0	WASHER		1	
7	00 0813 697 0	COMPRESS.SPRING		1	
8	00 0813 696 0	SLIDING PIN		1	
9	00 0941 475 0	EXTENSION FORKE		1	7)
9	00 0820 426 0	EXTENSION FORKE		1	8)
9	00 0820 427 0	EXTENSION FORKE		1	9)
10	00 0972 503 0	CIRCLIP		4	
11	00 0244 946 0	GREASE NIPPLE	B M8X1	2	
12	00 0242 908 0	CIRCLIP	32X1,2	4	
13	00 0820 421 0	CENTRE CROSS ASS.		2	
14	00 0921 267 0	WASHER		4	
15	00 0921 268 0	DOUBLE FORK		1	
16	00 0244 946 0	GREASE NIPPLE	B M8X1	1	
17	00 0941 486 0	FORK		1	
18	00 0244 581 2	SPRING PIN	10X 80	1	
19	00 0941 507 0	PROFILE TUBE		1	10)
20	00 0821 103 0	PROTECT.FUNNEL		1	
21	00 0920 671 0	GLIDE RING		2	
22	00 0824 446 0	PROTECTIVE TUBE		1	11)
23	00 0821 104 0	SUPPORTING CHAIN		1	
24	00 0827 171 0	DRIVE SHAFT HALF		1	12)
24	00 0827 234 0	DRIVE SHAFT HALF		1	13)
25	00 0823 180 0	GUARD HALF		1	11)
26	00 0972 297 0	SUPPORTING CHAIN		1	
27	00 0917 283 0	BACK-UP RING		1	
28	00 0813 018 1	PROTECT.FUNNEL		1	
29	00 0824 457 0	KEYOVERRUN CLUTCH		1	
30	00 0824 458 0	PROFILE TUBE		1	
31	00 0235 186 0	CIRCLIP	72X2,5	1	
32	00 0234 388 0	BACK-UP WASHER	S 56X 72	1	
33	00 0814 228 0	STOP KEY		2	
34	00 0814 229 0	FLAT SPRING		2	
35	00 0813 015 0	HUB		1	
36	00 0213 698 0	SPRING PIN	W.ERS.D.2136981	1	
37	00 0823 186 0	CLUTCH HOUSING		1	14)
37	00 0824 477 0	CLUTCH HOUSING		1	6)
38	00 0244 946 0	GREASE NIPPLE	B M8X1	1	
39	00 0244 946 0	GREASE NIPPLE	B M8X1	1	
40	00 0941 651 0	CENTRE CROSS ASS.		1	
41	00 0242 908 0	CIRCLIP	32X1,2	4	
42	00 0827 566 0	CAM DISK		1	15)
42	00 0827 568 0	CAM DISK		1	16)

1) Remarks

(1900 NM/540 U/MIN) 6 - TLG.
(1900 NM/540 U/MIN) 8 - TLG.
(1100 NM/1000 U/MIN) 6 - TLG.

UNIVERSAL DRIVE SHAFT WITH CUT - OUT CLU 1)

2) Remarks	6-pitch 540 rpm
3) Remarks	8-TLG. 540 U/MIN
4) Remarks	6-TLG. 1000 U/MIN
5) Remarks	tractor side 6-pitch 540+1000 rpm
6) Remarks	8-TLG. 540 U/MIN.
7) Remarks	6-piece connection
8) Remarks	21-TEIL. ANSCHLUSS
9) Remarks	8-TEIL. ANSCHLUSS
10) Remarks	1045 long
11) Remarks	1000 long
12) Remarks	machine side 6-pitch 540 rpm. 8-pitch 540 rpm.
13) Remarks	MASCHINENSEITE 6-TLG. 1000 U/MIN.
14) Remarks	6-pitch 540+1000 rpm
15) Remarks	see illustration plate 3 6 + 8-pitch 540 rpm.
16) Remarks	SIEHE BILDТАFEL 3 6-TLG. 1000 U/MIN.

3

Variant 180

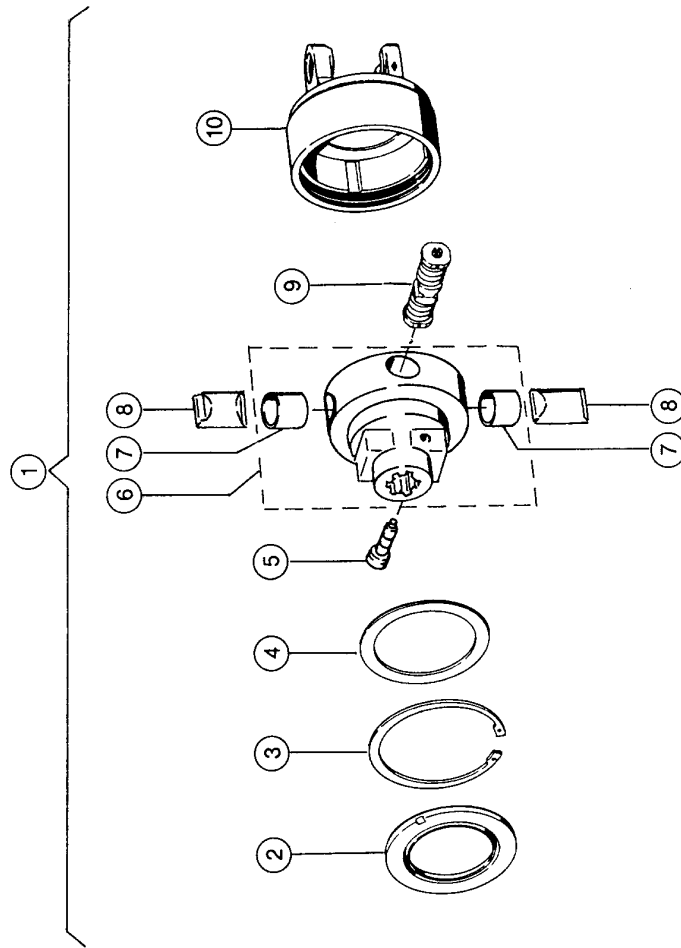

CLHHS

CAM - TYPE CUT - OUT CLUTCH 1)

Pos.	Part No.	Description	Dimension	Quantity	Conditions
1	00 0827 566 0	CAM DISK		1	2)
1	00 0827 568 0	CAM DISK		1	3)
2	00 0575 672 0	SEALING RING		1	
3	00 0235 196 0	CIRCLIP	150X4	1	
4	00 0613 966 0	BACK-UP WASHER	S120X150X3,5	1	
5	00 0826 067 0	CLAMPING CONE		1	
6	00 0823 999 0	HUB COMPLETE		1	4)
7	00 0941 490 0	BUSHING	35X39X40	2	
8	00 0941 491 0	CAM		2	
9	00 0827 567 0	SPRING KIT		1	2)
9	00 0827 569 0	SPRING KIT		1	3)
10	00 0940 439 0	CLUTCH HOUSING		1	

1) Remarks (1900 NM/540 U/MIN) 6 - TLG.
(1900 NM/540 U/MIN) 8 - TLG.
(1100 NM/1000 U/MIN) 6 - TLG.

2) Remarks 6 + 8-pitch 540 rpm.

3) Remarks 6-TLG. 1000 U/MIN.

4) Remarks with Item 7

4

Variant 180

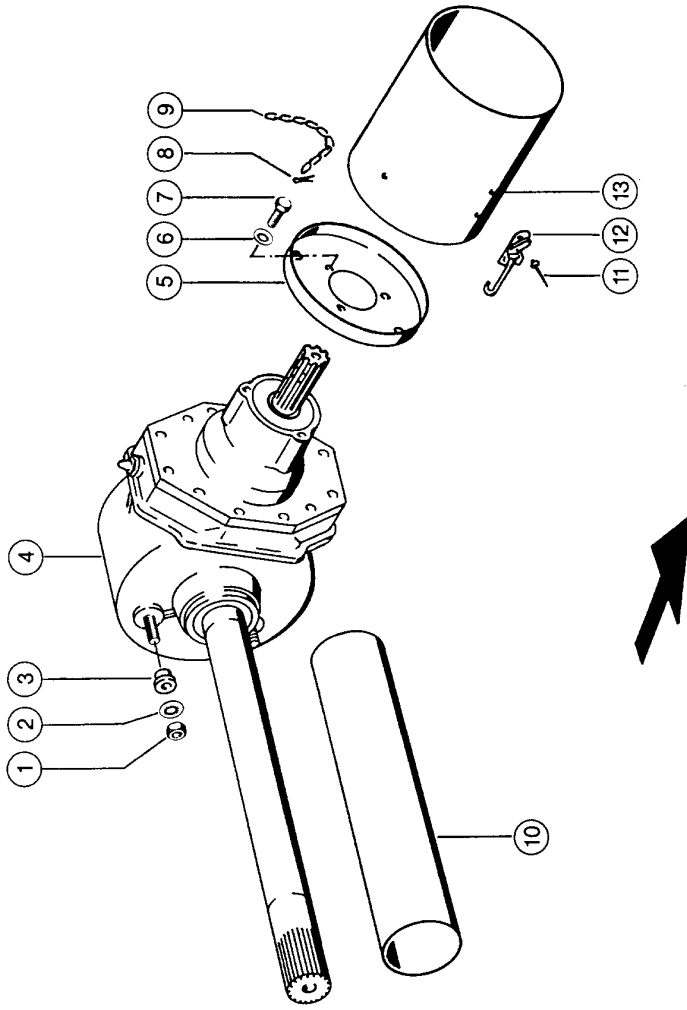

CLHHS

GEARBOX WITH INTERMEDIATE DRIVE ASSY., VAR. 9198 1)

Pos.	Part No.	Description	Dimension	Quantity	Conditions
1	00 0236 172 0	HEXAGONAL NUT	M12	2	
2	00 0239 389 0	CONTACT WASHER	A12	2	
3	00 0810 117 0	BUSHING	D30X20	2	
4	00 0823 829 0	ANGLE DRIVE	I=2,8	1	2)
5	00 0822 995 1	GUARD CUP		1	
6	00 0239 387 0	CONTACT WASHER	A8-8,2X18X1,4	3	
7	00 0237 439 0	HEXAGON HEAD BOLT	M8X16	3	
8	00 0235 089 0	SPLIT PIN	4 X 22	1	
9	00 0608 099 0	ROUND STEEL CHAIN	G 3X16-17GL	1	
10	00 0821 067 1	PROTECTIVE TUBE	D 110 X 496LG	1	
11	00 0237 922 1	BLIND RIVET	A 4X12	4	
12	00 0822 998 1	LOCK		2	
13	00 0822 996 0	PROTECT.TUBE CPL.		1	3)

1) Remarks

540 U/MIN.
UP TO SERIAL NO. 04700064
SEE ILLUSTRATION 4 A
VAR. 9785
FROM SERIAL NO. 04700065

2) Remarks

see illustration plate 5

3) Remarks

with Item 9, 11, 12

4A

Variant 180

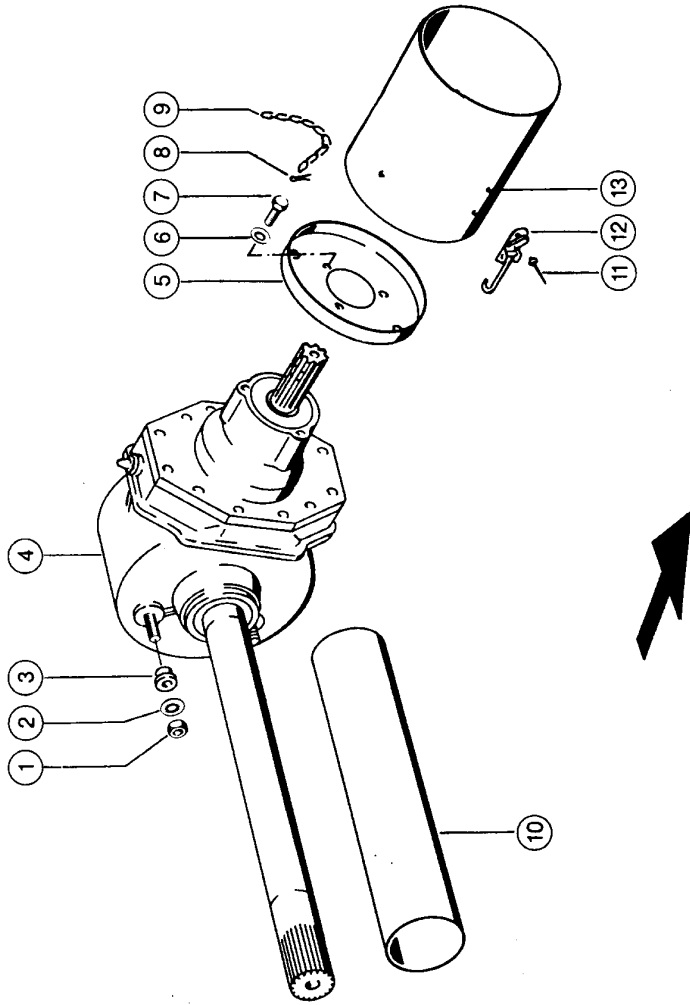

CLAAS

GEARBOX WITH INTERMEDIATE DRIVE ASSY., VAR. 9785 1)

Pos.	Part No.	Description	Dimension	Quantity	Conditions
1	00 0236 172 0	HEXAGONAL NUT	M12	2	
2	00 0239 389 0	CONTACT WASHER	A12	2	
3	00 0810 117 0	BUSHING	D30X20	2	
4	00 0827 167 0	ANGLE DRIVE		1	2)
5	00 0822 995 1	GUARD CUP		1	
6	00 0239 387 0	CONTACT WASHER	A8-8,2X18X1,4	3	
7	00 0237 439 0	HEXAGON HEAD BOLT	M8X16	3	
8	00 0235 089 0	SPLIT PIN	4 X 22	1	
9	00 0608 099 0	ROUND STEEL CHAIN	G 3X16-17GL	1	
10	00 0821 067 1	PROTECTIVE TUBE	D 110 X 496LG	1	
11	00 0237 922 1	BLIND RIVET	A 4X12	4	
12	00 0822 998 1	LOCK		2	
13	00 0822 996 0	PROTECT.TUBE CPL.		1	3)

1) Remarks	540 U/MIN. FROM SERIAL NO. 04700065
2) Remarks	see illustration plate 5 A
3) Remarks	with Item 9, 11, 12

5

CLHHS

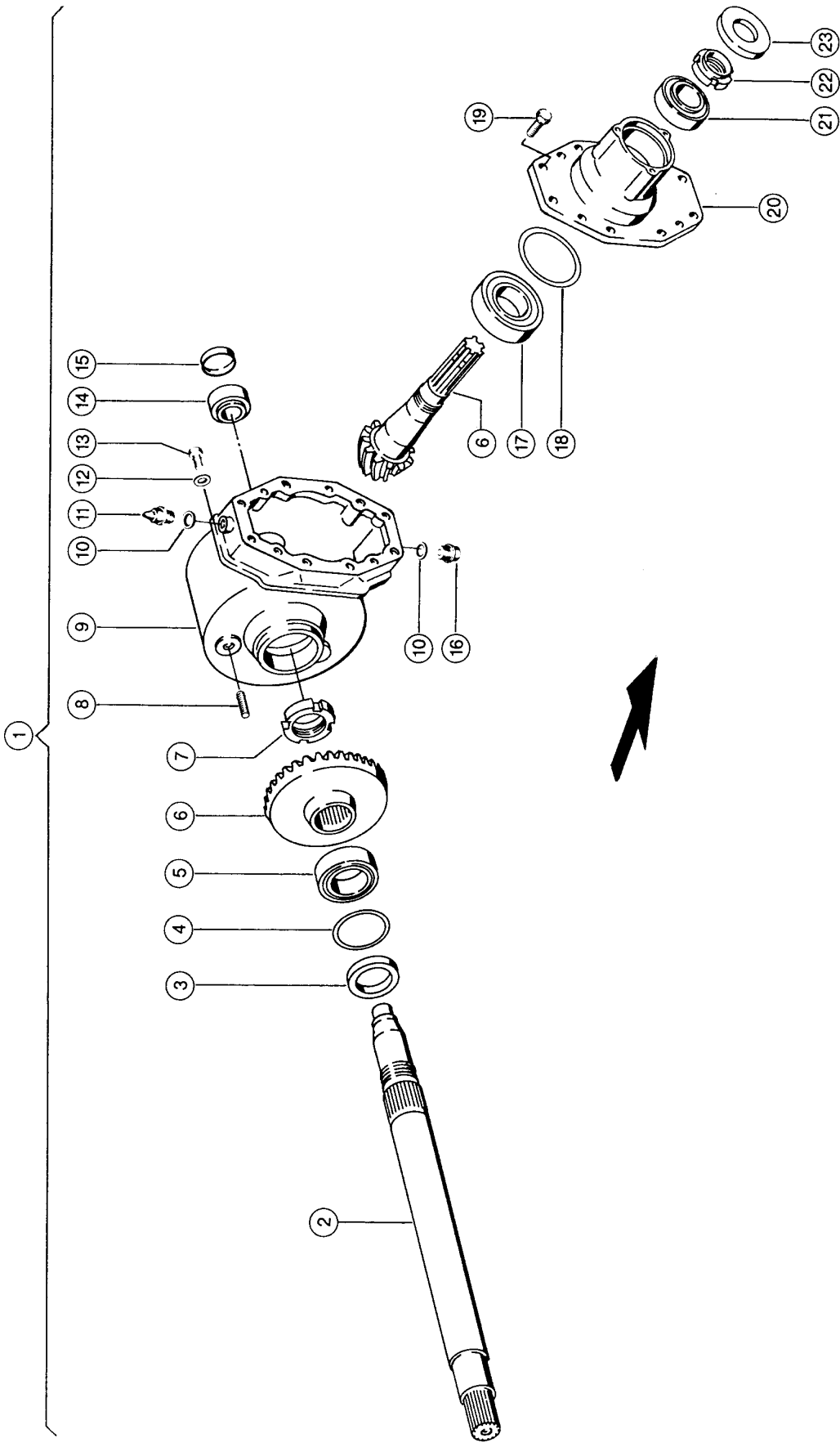

Variant 180

115359

ANGLE DRIVE, VAR. 9198 1)

Pos.	Part No.	Description	Dimension	Quantity	Conditions
1	00 0823 829 0	ANGLE DRIVE	I=2,8	1	
2	00 0823 943 0	SHAFT	854 LANG	1	
3	00 0211 034 0	ROTARY SHAFT SEAL	AS 60X 85X 8	1	
4	00 0213 765 0	SHIM	85X 95X0,5	1	2)
4	00 0213 764 0	SHIM	85X 95X0,3	1	3)
4	00 0213 763 0	SHIM	85X 95X0,2	1	4)
5	00 0212 210 0	TA.ROLLER BEARING	330 12	1	
6	00 0823 942 0	BEVEL GEAR SET	I=2,88	1	
7	00 0823 993 0	SLOTTED NUT	M55X1,5	1	
8	00 0213 769 0	STUD BOLT	M12X35 ERS.D.213769.1	2	
9	00 0823 941 0	HOUSING		1	
10	00 0235 786 0	SEALING RING	A16 X22	2	
11	00 0940 866 0	BREATHER VALVE	M 16X1,5 M. SPRITZROHR	1	
12	00 0244 842 0	SEALING RING	A10 X14	2	
13	00 0237 570 0	HEXAGON HEAD BOLT	M10X16	2	
14	00 0235 986 0	TA.ROLLER BEARING	302 06	1	
15	00 0213 767 0	LOCKING COVER	55X10	1	
16	00 0244 351 0	SCREW PLUG	M16X1,5	1	
17	00 0213 768 0	TA.ROLLER BEARING	313 11	1	
18	00 0233 010 0	SHIM	100X120X0,5	1	2)
18	00 0239 174 0	SHIM	100X120X0,3	1	3)
18	00 0211 873 0	SHIM	100X119,5X0,2	1	4)
19	00 0237 572 0	HEXAGON HEAD BOLT	M12X35	12	
20	00 0823 944 0	BEARING HOUSING		1	
21	00 0234 829 0	TA.ROLLER BEARING	30209 J2/Q	1	
22	00 0823 994 0	SLOTTED NUT	M45X1,5	1	
23	00 0213 766 0	SHAFT SEAL	AS 40X 90X12	1	

1) Remarks 540 U/MIN.
UP TO SERIAL NO. 04700064
SEE ILLUSTRATION 5 A
VAR. 9785
FROM SERIAL NO. 04700065

2) Remarks 0.5 mm

3) Remarks 0,3 MM

4) Remarks 0,2 MM

5A

CLAAS

VARIANT 180 / RC

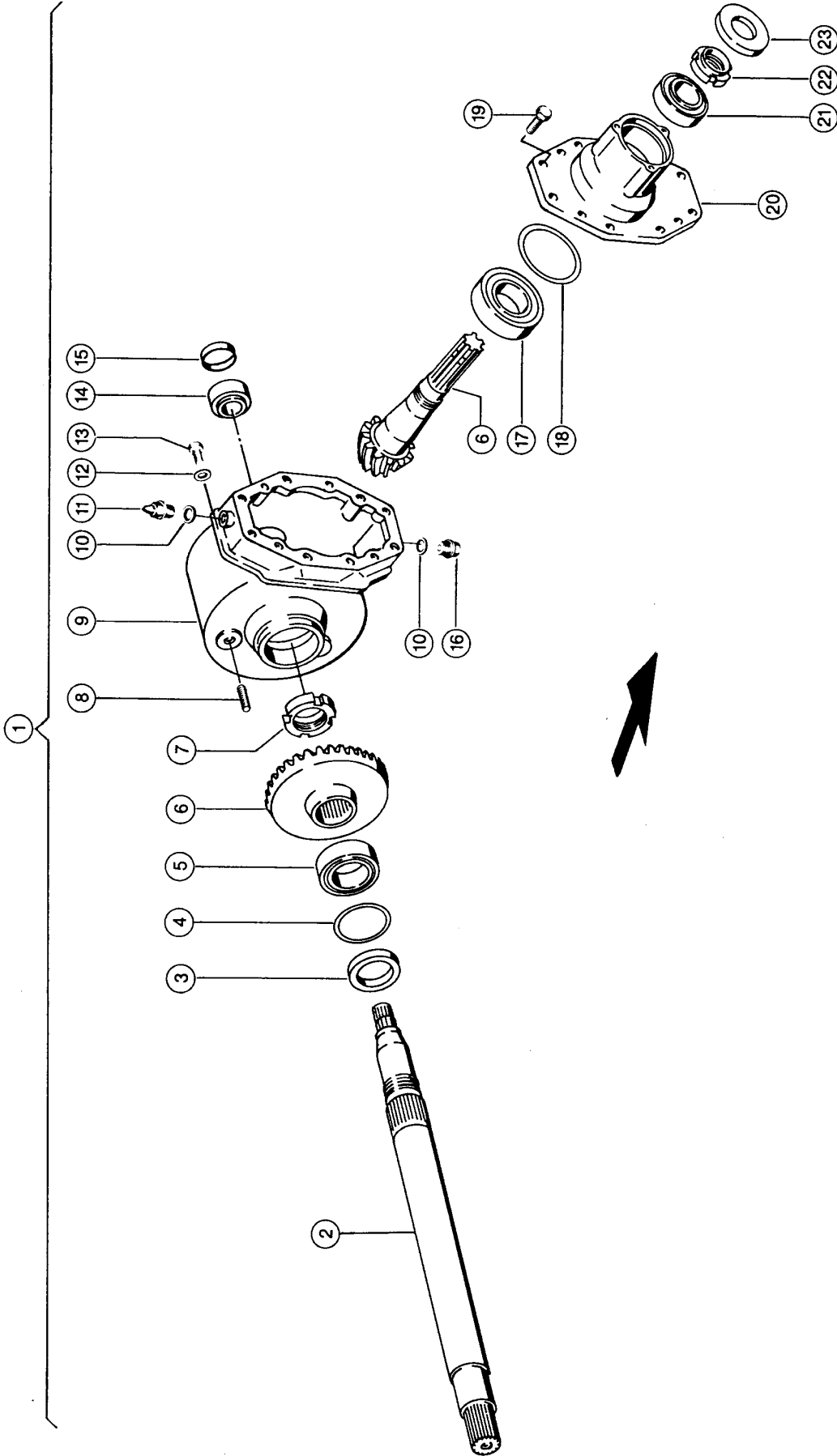

Variant 180

115542

Thank you so much for reading.
Please click the “Buy Now!”
button below to download the
complete manual.



After you pay.

You can download the most
perfect and complete manual in
the world immediately.

Our support email:

ebooklibonline@outlook.com